

## FEATURES

- Programmable microphone bias (5 V to 9 V) with diagnostics**
- Four 10 V rms capable direct-coupled differential inputs**
- On-chip PLL for master clock**
- Low EMI design**
- 109 dB ADC dynamic range**
- −95 dB THD + N**
- Selectable digital high-pass filter**
- 24-bit ADC with 8 kHz to 192 kHz sample rates**
- Digital volume control with autoramp function**
- I<sup>2</sup>C/SPI control**
- Software-controllable clickless mute**
- Software power-down**
- Right justified, left justified, I<sup>2</sup>S justified, and TDM modes**
- Master and slave operation modes**
- 40-lead LFCSP package**
- Qualified for automotive applications**

## APPLICATIONS

- Automotive audio systems**
- Active noise cancellation system**

## GENERAL DESCRIPTION

The ADAU1977 incorporates four high performance analog-to-digital converters (ADCs) with direct-coupled inputs capable of 10 V rms. The ADC uses multibit sigma-delta ( $\Sigma$ - $\Delta$ ) architecture with continuous time front end for low EMI. The ADCs can be connected to the electret microphone (ECM) directly and provide the bias for powering the microphone. Built-in diagnostic circuitry detects faults on input lines and includes comprehensive diagnostics for faults on microphone inputs. The faults reported are short to battery, short to microphone bias, short to ground, short between positive and negative input pins, and open input terminals. In addition, each diagnostic fault is available as an IRQ flag for ease in system design. An I<sup>2</sup>C/SPI control port is also included. The ADAU1977 uses only a single 3.3 V supply. The part internally generates the microphone bias voltage. The microphone bias is programmable in a few steps from 5 V to 9 V. The low power architecture reduces the power consumption. An on-chip PLL can derive the master clock from an external clock input or frame clock (sample rate clock). When fed with a frame clock, the PLL eliminates the need for a separate high frequency master clock in the system. The ADAU1977 is available in a 40-lead LFCSP package.

## FUNCTIONAL BLOCK DIAGRAM

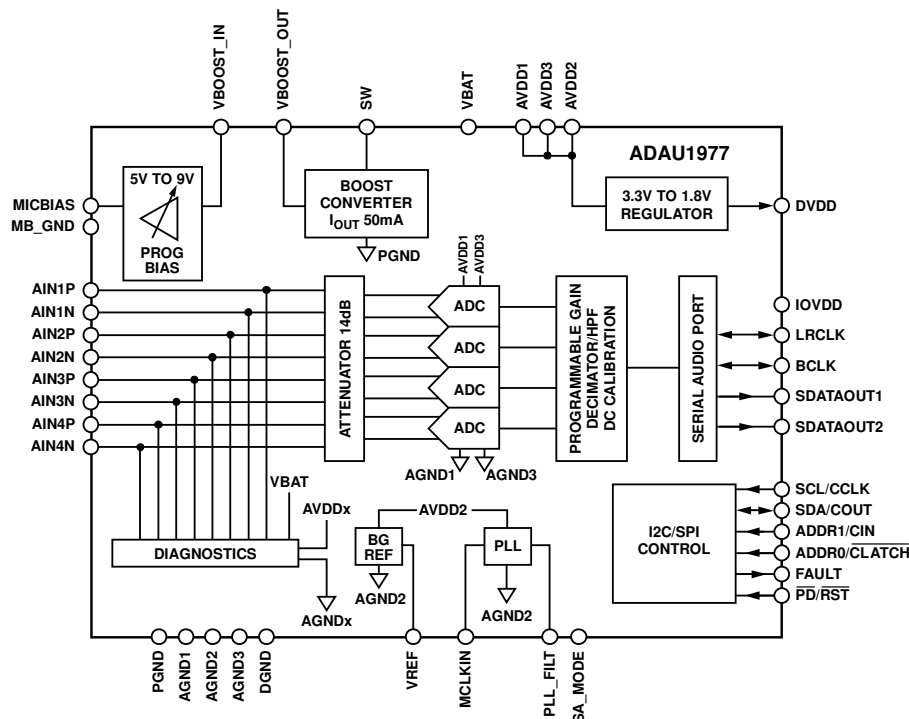

Figure 1.

Rev. C

[Document Feedback](#)

Information furnished by Analog Devices is believed to be accurate and reliable. However, no responsibility is assumed by Analog Devices for its use, nor for any infringements of patents or other rights of third parties that may result from its use. Specifications subject to change without notice. No license is granted by implication or otherwise under any patent or patent rights of Analog Devices. Trademarks and registered trademarks are the property of their respective owners.

One Technology Way, P.O. Box 9106, Norwood, MA 02062-9106, U.S.A.  
 Tel: 781.329.4700 ©2013–2014 Analog Devices, Inc. All rights reserved.  
[Technical Support](#) [www.analog.com](http://www.analog.com)

## TABLE OF CONTENTS

Features .....	1	Register Details .....	37
Applications .....	1	Master Power and Soft Reset Register .....	37
General Description .....	1	PLL Control Register .....	38
Functional Block Diagram .....	1	DC-to-DC Boost Converter Control Register .....	39
Revision History .....	3	MICBIAS and Boost Control Register .....	40
Specifications .....	4	Block Power Control and Serial Port Control Register .....	41
Analog Performance Specifications .....	4	Serial Port Control Register1 .....	42
Diagnostic and Fault Specifications .....	5	Serial Port Control Register2 .....	43
Digital Input/Output Specifications .....	6	Channel Mapping for Output Serial Ports Register .....	44
Power Supply Specifications .....	6	Channel Mapping for Output Serial Ports Register .....	46
Digital Filters Specifications .....	7	Serial Output Drive and Overtemperature Protection	
Timing Specifications .....	8	Control Register .....	48
Absolute Maximum Ratings .....	10	Post ADC Gain Channel 1 Control Register .....	49
Thermal Resistance .....	10	Post ADC Gain Channel 2 Control Register .....	50
ESD Caution .....	10	Post ADC Gain Channel 3 Control Register .....	51
Pin Configuration and Function Descriptions .....	11	Post ADC Gain Channel 4 Control Register .....	52
Typical Performance Characteristics .....	13	High-Pass Filter and DC Offset Control Register and	
Theory of Operation .....	15	Master Mute .....	53
Overview .....	15	Diagnostics Control Register .....	54
Power Supply and Voltage Reference .....	15	Diagnostics Report Register Channel 1 .....	55
Power-On Reset Sequence .....	15	Diagnostics Report Register Channel 2 .....	56
PLL and Clock .....	16	Diagnostics Report Register Channel 3 .....	57
DC-to-DC Boost Converter .....	17	Diagnostics Report Register Channel 4 .....	58
Microphone Bias .....	18	Diagnostics Interrupt Pin Control Register 1 .....	59
Analog Inputs .....	18	Diagnostics Interrupt Pin Control Register 2 .....	60
ADC .....	22	Diagnostics Adjustments Register 1 .....	61
ADC Summing Modes .....	22	Diagnostics Adjustments Register 2 .....	62
Diagnostics .....	23	ADC Clipping Status Register .....	63
Serial Audio Data Output Ports—Data Format .....	25	Digital DC High-Pass Filter and Calibration Register .....	64
Control Ports .....	30	Applications Circuit .....	65
I <sup>2</sup> C Mode .....	31	Outline Dimensions .....	66
SPI Mode .....	34	Ordering Guide .....	66
Register Summary .....	36	Automotive Products .....	66

**REVISION HISTORY**

**1/14—Rev. B to Rev. C**

Change to Features Section ..... 1  
Change to Dynamic Range (A-Weighted) Parameter, Table 1.... 4  
Change to Figure 9 ..... 13  
Change to Figure 36 ..... 32  
Change to Figure 46 ..... 65

**9/13—Rev. A to Rev. B**

Changes to Figure 1 ..... 1  
Moved Revision History Section..... 3  
Changes to Figure 14 ..... 16  
Changes to Figure 46 ..... 65

**3/13—Rev. 0 to Rev. A**

Changed CP-40-9 to CP-40-14 ..... Universal  
Changes to Hysteresis AINxP and AINxN Shorted Together  
Parameter, Table 2 ..... 4  
Changes to Thermal Resistance Section and Table 8 ..... 9  
Changes to SPI Mode Section ..... 32  
Changes to Channel Mapping for Output Serial Ports Register  
Section and Table 34 ..... 44  
Changes to Figure 46 ..... 63  
Changes to Ordering Guide..... 64

**1/13—Revision 0: Initial Version**

## SPECIFICATIONS

Performance of all channels is identical, exclusive of the interchannel gain mismatch and interchannel phase deviation specifications. AVDDx/IOVDD = 3.3 V; DVDD (internally generated) = 1.8 V; VBAT = 14.4 V; T<sub>A</sub> = -40°C to +105°C, unless otherwise noted; master clock = 12.288 MHz (48 kHz f<sub>s</sub>, 256 × f<sub>s</sub> mode); input sample rate = 48 kHz; measurement bandwidth = 20 Hz to 20 kHz; word width = 24 bits; load capacitance (digital output) = 20 pF; load current (digital output) = ±1 mA; digital input voltage high = 2.0 V; digital input voltage low = 0.8 V.

### ANALOG PERFORMANCE SPECIFICATIONS

Table 1.

Parameter	Test Conditions/Comments	Min	Typ	Max	Unit
<b>LINE INPUT APPLICATION</b>					
Full-Scale Differential Input Voltage	See Figure 46 DC-coupled, V <sub>CM</sub> at AINxP/AINxN = 7 V		10		V rms
Full-Scale Single-Ended Input Voltage	DC-coupled, V <sub>CM</sub> at AINxP/AINxN = 7 V		5		V rms
<b>MICROPHONE INPUT APPLICATION</b>					
Differential Input Voltage	See Figure 46, MICBIAS = 8.5 V DC-coupled, V <sub>CM</sub> at AINxP = 5.66 V, AINxN = 2.83 V		2		V rms
<b>QUASI DC INPUT</b>					
Single-Ended Input Voltage			5		V peak
Input Common-Mode Voltage	V <sub>CM</sub> at AINxP/AINxN pins	0		8	V dc
Peak Input Voltage	V <sub>CM</sub> + V ac peak at AINxP/AINxN pins	0		14	V
<b>MICROPHONE BIAS</b>					
Output Voltage	Programmable from 5 V to 9 V in steps of 0.5 V; the output voltage is within the specified load regulation	5		9	V
Load Regulation	From no load to maximum load of 25 mA at 5 V	-1	+0.2	+1	%
	From no load to maximum load of 45 mA at 9 V	-1	+0.3	+1	%
Output Current	At MICBIAS = 5 V			25	mA
	At MICBIAS = 9 V			45	mA
Output Noise	20 Hz to 20 kHz, MICBIAS = 5 V		22	32	μV rms
	20 Hz to 20 kHz, MICBIAS = 9 V		35	54	μV rms
Power Supply Rejection Ratio (PSRR)	350 mV rms, 1 kHz ripple on VBOOST_IN at 10 V		60		dB
Interchannel Isolation at MICBIAS Pin	Referred to full scale at 1 kHz		60		dB
Start-Up Time	With C <sub>LOAD</sub> = 1 nF		40		ms
<b>BOOST CONVERTER</b>					
Input Voltage		2.97	3.3	3.63	V
Input Current	L = 4.7 μH, f <sub>SW</sub> = 1.536 MHz, MICBIAS = 9 V at 45 mA load		195		mA
	L = 2.2 μH, f <sub>SW</sub> = 3.072 MHz, MICBIAS = 9 V at 45 mA load		220		mA
Output Current	MICBIAS = 5 V		50		mA
	MICBIAS = 9 V		88		mA
Load Regulation	From no load to maximum load of 50 mA at MICBIAS = 5 V	-1		+1	%
	From no load to maximum load of 88 mA at MICBIAS = 9 V	-1		+1	%
Input Overcurrent Threshold			900		mA peak
Switching Frequency	f <sub>s</sub> = 48 kHz L = 2.2 μH		3.072		MHz
	f <sub>s</sub> = 48 kHz, L = 4.7 μH		1.536		MHz
External Load Capacitor at VBOOST_OUT Pin		4.7	10	22	μF
<b>ANALOG-TO-DIGITAL CONVERTERS</b>					
Input Resistance					
Differential	Between AINxP and AINxN		50		kΩ
Single-Ended (R <sub>in1977</sub> )	Between AINxP and AINxN		25		kΩ
ADC Resolution			24		Bits
Dynamic Range (A-Weighted) <sup>1</sup>	Input = 1 kHz, -60 dBFS				
Line Input	Referred to full-scale differential input = 10 V rms	103	109		dB
Microphone Input	Referred to full-scale differential input = 2 V rms		95		dB
Total Harmonic Distortion Plus Noise (THD + N)	Input = 1 kHz, -1 dBFS (0 dBFS = 10 V rms input)		-95	-89	dB

Parameter	Test Conditions/Comments	Min	Typ	Max	Unit
Digital Gain Post ADC	Gain step size = 0.375 dB	-35.625		+60	dB
Gain Error		-10		+10	%
Interchannel Gain Mismatch		-0.25		+0.25	dB
Gain Drift			0.6		ppm/°C
Common-Mode Rejection Ratio (CMRR)	1 V rms, 1 kHz		60		dB
	1 V rms, 20 kHz		56		dB
Power Supply Rejection Ratio (PSRR)	100 mV rms, 1 kHz on AVDDx = 3.3 V		70		dB
Interchannel Isolation			100		dB
Interchannel Phase Deviation			0		Degrees
REFERENCE					
Internal Reference Voltage	VREF pin	1.47	1.50	1.54	V
Output Impedance			20		kΩ
ADC SERIAL PORT					
Output Sample Rate		8		192	kHz

<sup>1</sup> For  $f_s$  ranging from 44.1 kHz to 192 kHz.

## DIAGNOSTIC AND FAULT SPECIFICATIONS

Applicable to differential microphone input using MICBIAS on AINxP and AINxN pins.

Table 2.

Parameter	Test Conditions/Comments	Min	Typ	Max	Unit
INPUT VOLTAGE THRESHOLDS FOR FAULT DETECTION <sup>1</sup>					
Hysteresis AINxP or AINxN Shorted to VBAT	SHT_B_TRIP = 10	$0.79 \times \text{VBAT}$	$0.85 \times \text{VBAT}$	$0.86 \times \text{VBAT}$	V
	SHT_B_TRIP = 01	$0.84 \times \text{VBAT}$	$0.9 \times \text{VBAT}$	$0.91 \times \text{VBAT}$	V
	SHT_B_TRIP = 00	$0.89 \times \text{VBAT}$	$0.95 \times \text{VBAT}$	$0.96 \times \text{VBAT}$	V
	SHT_B_TRIP = 11	$0.93 \times \text{VBAT}$	$0.975 \times \text{VBAT}$	$0.99 \times \text{VBAT}$	V
Hysteresis AINxP and AINxN Shorted Together	SHT_T_TRIP = 00	$\text{MICBIAS}(0.5 \pm 0.015)$	$\text{MICBIAS}(0.5 \pm 0.035)$	$\text{MICBIAS}(0.5 \pm 0.047)$	V
	SHT_T_TRIP = 01	$\text{MICBIAS}(0.5 \pm 0.001)$	$\text{MICBIAS}(0.5 \pm 0.017)$	$\text{MICBIAS}(0.5 \pm 0.03)$	V
	SHT_T_TRIP = 10	$\text{MICBIAS}(0.5 \pm 0.05)$	$\text{MICBIAS}(0.5 \pm 0.071)$	$\text{MICBIAS}(0.5 \pm 0.08)$	V
Hysteresis AINxP or AINxN Shorted to Ground	SHT_G_TRIP = 10	$0.04 \times \text{VREF}$	$0.1 \times \text{VREF}$	$0.13 \times \text{VREF}$	V
	SHT_G_TRIP = 01	$0.08 \times \text{VREF}$	$0.133 \times \text{VREF}$	$0.16 \times \text{VREF}$	V
	SHT_G_TRIP = 00	$0.12 \times \text{VREF}$	$0.2 \times \text{VREF}$	$0.22 \times \text{VREF}$	V
	SHT_G_TRIP = 11	$0.19 \times \text{VREF}$	$0.266 \times \text{VREF}$	$0.28 \times \text{VREF}$	V
Hysteresis AINxP Shorted to MICBIAS	SHT_M_TRIP = 10	$0.82 \times \text{MICBIAS}$	$0.85 \times \text{MICBIAS}$	$0.89 \times \text{MICBIAS}$	V
	SHT_M_TRIP = 01	$0.87 \times \text{MICBIAS}$	$0.9 \times \text{MICBIAS}$	$0.94 \times \text{MICBIAS}$	V
	SHT_M_TRIP = 00	$0.92 \times \text{MICBIAS}$	$0.95 \times \text{MICBIAS}$	$1.0 \times \text{MICBIAS}$	V
	SHT_M_TRIP = 11	$0.95 \times \text{MICBIAS}$	$0.975 \times \text{MICBIAS}$	$1.0 \times \text{MICBIAS}$	V
Hysteresis AINxP or AINxN Open Circuit <sup>2</sup>	Refer to the AINxP shorted to MICBIAS and the AINxN shorted to ground specifications for upper and lower thresholds.				
FAULT DURATION	Programmable	10	100	150	ms

<sup>1</sup> The threshold limits are tested with VREF = 1.5 V, MICBIAS = 5 V to 8.5 V, and VBAT = 11 V to 18 V set using an external source. When  $\text{VBAT} \leq \text{MICBIAS}$ , a short to VBAT cannot be distinguished from a short to MICBIAS, and reporting a short to VBAT fault takes precedence over a short to MICBIAS fault.

<sup>2</sup> The AINxP open terminal fault cannot be distinguished from the AINxN open terminal fault because the voltage at the AINxP and AINxN pins remain at MICBIAS and ground, respectively, when either of these two terminals becomes open circuit.

**DIGITAL INPUT/OUTPUT SPECIFICATIONS**

Table 3.

Parameter	Test Conditions/Comments	Min	Max	Unit
INPUT				
High Level Input Voltage ( $V_{IH}$ )		$0.7 \times IOVDD$		V
Low Level Input Voltage ( $V_{IL}$ )			$0.3 \times IOVDD$	V
Input Leakage Current			$\pm 10$	$\mu A$
Input Capacitance			5	pF
OUTPUT				
High Level Output Voltage ( $V_{OH}$ )	$I_{OH} = 1 \text{ mA}$	$IOVDD - 0.60$		V
Low Level Output Voltage ( $V_{OL}$ )	$I_{OL} = 1 \text{ mA}$		0.4	V

**POWER SUPPLY SPECIFICATIONS**

$L = 4.7 \mu H$ ,  $AVDDx = 3.3 \text{ V}$ ,  $DVDD = 1.8 \text{ V}$ ,  $IOVDD = 3.3 \text{ V}$ ,  $f_s = 48 \text{ kHz}$  (master mode), unless otherwise noted.

Table 4.

Parameter	Test Conditions/Comments	Min	Typ	Max	Unit
DVDD	On-chip LDO	1.62	1.8	1.98	V
AVDDx		3.0	3.3	3.6	V
IOVDD		1.62	3.3	3.6	V
VBAT <sup>1</sup>			14.4	18	V
IOVDD Current					
Master clock = 256 $f_s$					
Normal Operation	$f_s = 48 \text{ kHz}$		450		$\mu A$
	$f_s = 96 \text{ kHz}$		880		$\mu A$
	$f_s = 192 \text{ kHz}$		1.75		mA
Power-Down	$f_s = 48 \text{ kHz to } 192 \text{ kHz}$		20		$\mu A$
AVDDx Current					
Normal Operation	Boost off, 4-channel ADC, DVDD internal		14		mA
	Boost on, 4-channel ADC, DVDD internal		14.5		mA
	Boost off, 4-channel ADC, DVDD external		9.6		mA
	Boost on, 4-channel ADC, DVDD external		10.1		mA
	Power-Down			270	
Boost Converter Current					
Normal Operation	Boost on, 4-channel ADC, MICBIAS = 8.5 V, no load		34		mA
	Boost on, 4-channel ADC, MICBIAS = 8.5 V, 42 mA		168		mA
	Power-Down		180		$\mu A$
DVDD Current					
Normal Operation	DVDD external = 1.8 V		4.5		mA
Power-Down			65		$\mu A$
VBAT Current					
Normal Operation	VBAT = 14.4 V		575	625	$\mu A$
Power-Down			575	625	$\mu A$
POWER DISSIPATION					
Normal Operation	Master clock = 256 $f_s$ , 48 kHz				
	DVDD internal, MICBIAS = 8.5 V at 42 mA load		265		mW
Power-Down, All Supplies	$\overline{PD}/\overline{RST}$ pin held low		9		mW

<sup>1</sup> When  $VBAT \leq MICBIAS$ , a short to VBAT cannot be distinguished from a short to MICBIAS, and reporting a short to VBAT fault takes precedence over a short to MICBIAS fault.

**DIGITAL FILTERS SPECIFICATIONS**

Table 5.

Parameter	Mode	Factor	Min	Typ	Max	Unit
ADC DECIMATION FILTER	All modes, typical at $f_s = 48$ kHz					
Pass Band		$0.4375 \times f_s$		21		kHz
Pass-Band Ripple				$\pm 0.015$		dB
Transition Band		$0.5 \times f_s$		24		kHz
Stop Band		$0.5625 \times f_s$		27		kHz
Stop-Band Attenuation			79			dB
Group Delay	$f_s = 8$ kHz to 96 kHz	$22.9844/f_s$		479		$\mu$ s
	$f_s = 192$ kHz			35		$\mu$ s
HIGH-PASS FILTER	All modes, typical at 48 kHz					
Cutoff Frequency	At $-3$ dB point			0.9375		Hz
Phase Deviation	At 20 Hz			10		Degrees
Settling Time						
ADC DIGITAL GAIN	All modes		0		60	dB
Gain Step Size				0.375		dB

**TIMING SPECIFICATIONS**

Table 6.

Parameter	Limit at		Unit	Description
	Min	Max		
INPUT MASTER CLOCK (MCLK)				
Duty Cycle	40	60	%	MCLKIN duty cycle; MCLKIN at $256 \times f_s$ , $384 \times f_s$ , $512 \times f_s$ , and $768 \times f_s$
$f_{MCLK}$	See Table 10		MHz	MCLKIN frequency, PLL in MCLK mode
RESET				
Reset Pulse	15		ns	$\overline{RST}$ low
PLL				
Lock Time		10	ms	
I <sup>2</sup> C PORT				
$f_{SCL}$		400	kHz	SCL frequency
$t_{SCLH}$	0.6		$\mu$ s	SCL high
$t_{SCLL}$	1.3		$\mu$ s	SCL low
$t_{SCS}$	0.6		$\mu$ s	Setup time; relevant for repeated start condition
$t_{SCH}$	0.6		$\mu$ s	Hold time; after this period of time, the first clock pulse is generated
$t_{DS}$	100		ns	Data setup time
$t_{DH}$	0			Data hold time
$t_{SCR}$		300	ns	SCL rise time
$t_{SCF}$		300	ns	SCL fall time
$t_{SDR}$		300	ns	SDA rise time
$t_{SDF}$		300	ns	SDA fall time
$t_{BFT}$	1.3		$\mu$ s	Bus-free time; time between stop and start
$t_{SUSTO}$	0.6		$\mu$ s	Setup time for stop condition
SPI PORT				
$t_{CCPH}$	35		ns	CCLK high
$t_{CCPL}$	35		ns	CCLK low
$f_{CCLK}$		10	MHz	CCLK frequency
$t_{CDS}$	10		ns	CIN setup to CCLK rising
$t_{CDH}$	10		ns	CIN hold from CCLK rising
$t_{CLS}$	10		ns	$\overline{CLATCH}$ setup to CCLK rising
$t_{CLH}$	40		ns	$\overline{CLATCH}$ hold from CCLK rising
$t_{CLPH}$	10		ns	$\overline{CLATCH}$ high
$t_{COE}$		30	ns	COU <sub>T</sub> enable from $\overline{CLATCH}$ falling
$t_{COD}$		30	ns	COU <sub>T</sub> delay from CCLK falling
$t_{COTS}$		30	ns	COU <sub>T</sub> tristate from $\overline{CLATCH}$ rising
ADC SERIAL PORT				
$t_{ABH}$	10		ns	BCLK high, slave mode
$t_{ABL}$	10		ns	BCLK low, slave mode
$t_{ALS}$	10		ns	LRCLK setup to BCLK rising, slave mode
$t_{ALH}$	5		ns	LRCLK hold from BCLK rising, slave mode
$t_{ABDD}$		18	ns	SDATAOUT <sub>x</sub> delay from BCLK falling



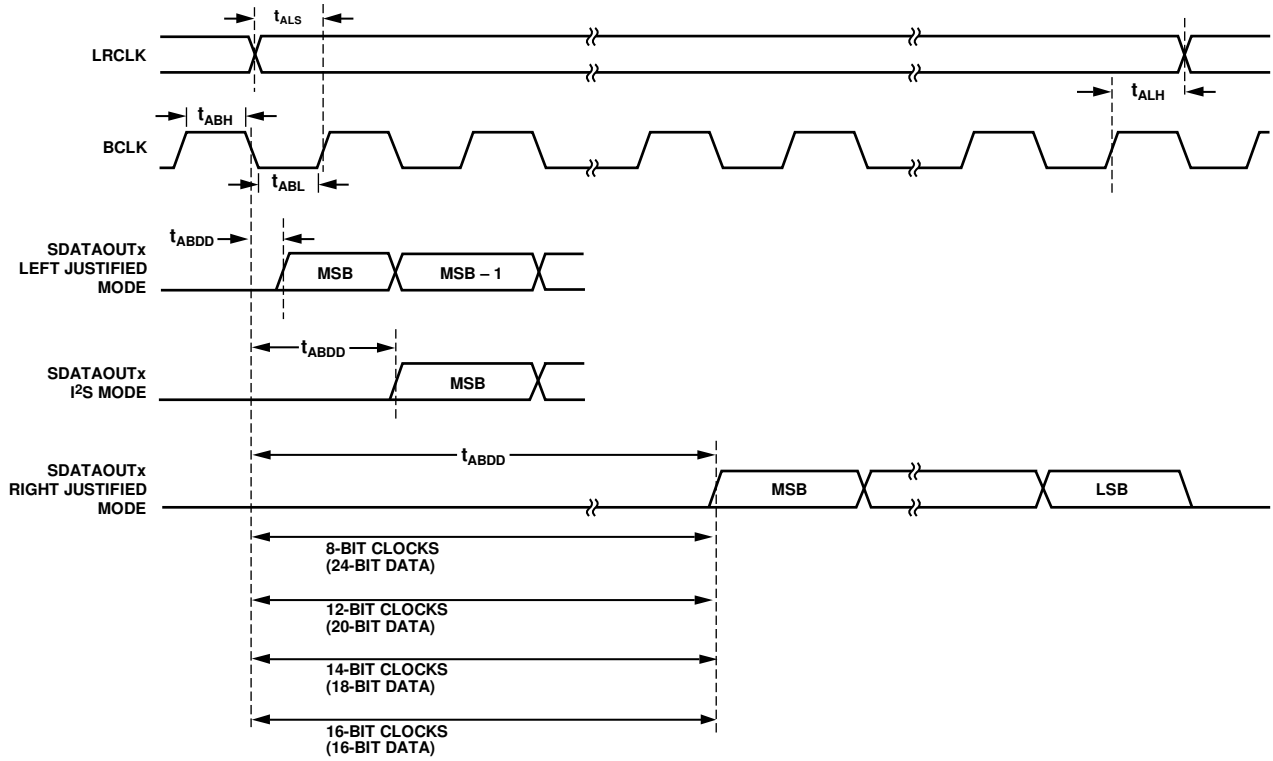

Figure 2. Serial Output Port Timing

1029E-002

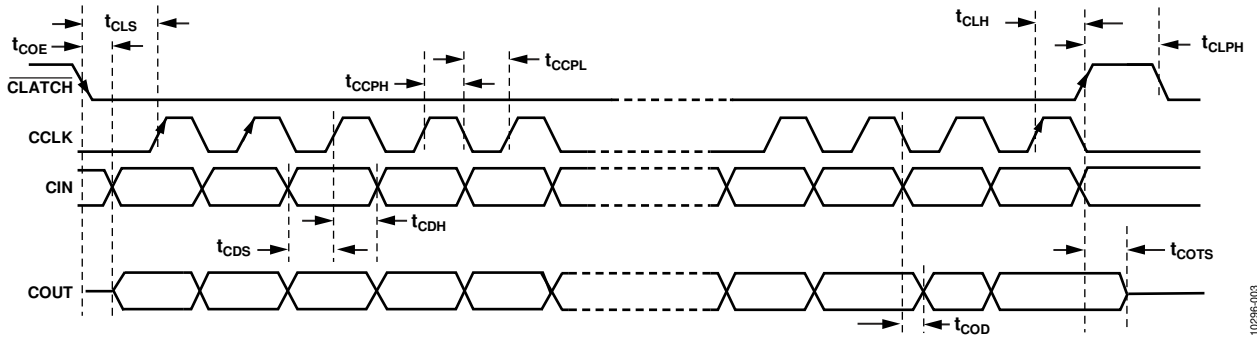

Figure 3. SPI Port Timing

1029E-003

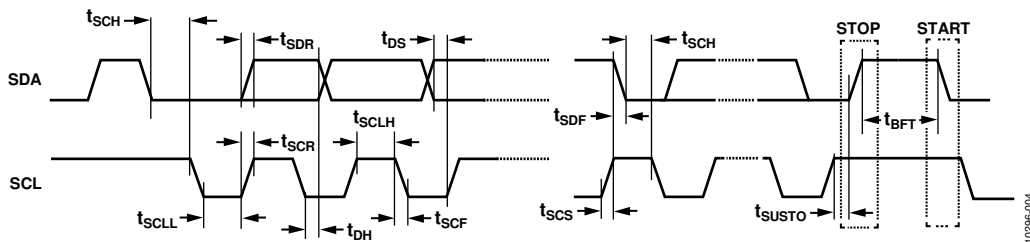

Figure 4. I²C Port Timing

1029E-004

## ABSOLUTE MAXIMUM RATINGS

Table 7.

Parameter	Rating
Analog Supply (AVDDx)	-0.3 V to +3.63 V
Digital Supply	
DVDD	-0.3 V to +1.98 V
IOVDD	-0.3 V to +3.63 V
Input Current (Except Supply Pins)	±20 mA
Analog Input Voltage (AINx, VBAT Pins)	-0.3 V to +18 V
Digital Input Voltage (Signal Pins)	-0.3 V to +3.63 V
Operating Temperature Range (Ambient)	-40°C to +105°C
Junction Temperature Range	-40°C to +125°C
Storage Temperature Range	-65°C to +150°C

Stresses above those listed under Absolute Maximum Ratings may cause permanent damage to the device. This is a stress rating only; functional operation of the device at these or any other conditions above those indicated in the operational section of this specification is not implied. Exposure to absolute maximum rating conditions for extended periods may affect device reliability.

## THERMAL RESISTANCE

$\theta_{JA}$  represents thermal resistance, junction-to-ambient, and  $\theta_{JC}$  represents the thermal resistance, junction-to-case. All characteristics are for a standard JEDEC board per JESD51.

Table 8. Thermal Resistance

Package Type	$\theta_{JA}$	$\theta_{JC}$	Unit
40-Lead LFCSP	32.8	1.93	°C/W

## ESD CAUTION



**ESD (electrostatic discharge) sensitive device.** Charged devices and circuit boards can discharge without detection. Although this product features patented or proprietary protection circuitry, damage may occur on devices subjected to high energy ESD. Therefore, proper ESD precautions should be taken to avoid performance degradation or loss of functionality.

# PIN CONFIGURATION AND FUNCTION DESCRIPTIONS

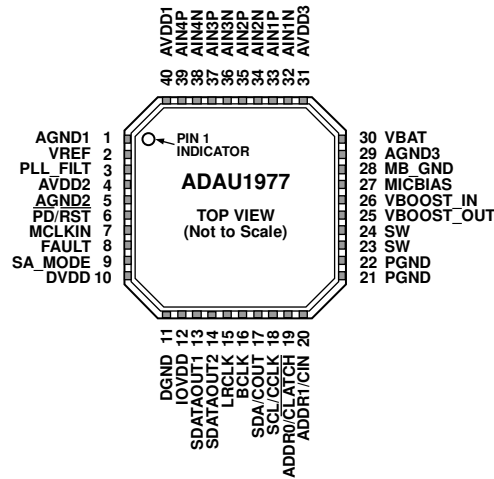

NOTES  
 1. THE EXPOSED PAD MUST BE CONNECTED TO THE GROUND PLANE ON THE PCB.

Figure 5. Pin Configuration, 40-Lead LFCSP

Table 9. Pin Function Descriptions

Pin No.	Mnemonic	In/Out <sup>1</sup>	Description
1	AGND1	P	Analog Ground.
2	VREF	O	Voltage Reference. Decouple this pin to AGNDx with 10 μF  100 nF capacitors.
3	PLL_FILT	O	PLL Loop Filter. Return this pin to AVDDx using recommended loop filter components.
4	AVDD2	P	Analog Power Supply. Connect this pin to analog 3.3 V supply.
5	AGND2	P	Analog Ground.
6	PD/RST	I	Power-Down Reset (Active Low).
7	MCLKIN	I	Master Clock Input.
8	FAULT	O	Fault Output. Programmable logic output.
9	SA_MODE	I	Standalone Mode. Connect this pin to IOVDD using a 10 kΩ pull-up resistor for standalone mode.
10	DVDD	O	1.8 V Digital Power Supply Output. Decouple this pin to DGND with a 0.1 μF capacitor.
11	DGND	P	Digital Ground.
12	IOVDD	P	Digital Input and Output Power Supply. Connect this pin to a supply in the range of 1.8 V to 3.3 V.
13	SDATAOUT1	O	ADC Serial Data Output Pair 1.
14	SDATAOUT2	O	ADC Serial Data Output Pair 2.
15	LRCLK	I/O	Frame Clock for the ADC Serial Port.
16	BCLK	I/O	Bit Clock for the ADC Serial Port.
17	SDA/COU	I/O	Serial Data Output I <sup>2</sup> C/Control Data Output (SPI).
18	SCL/CCLK	I	Serial Clock Input I <sup>2</sup> C/Control Clock Input (SPI).
19	ADDR0/CLATCH	I	Chip Address Bit 0 Setting I <sup>2</sup> C/Chip Select Input for Control Data (SPI).
20	ADDR1/CIN	I	Chip Address Bit 1 Setting I <sup>2</sup> C/Control Data Input (SPI).
21	PGND	P	Power Ground Boost Converter.
22	PGND	P	Power Ground Boost Converter.
23	SW	I	Inductor Switching Terminal.
24	SW	I	Inductor Switching Terminal.
25	VBOOST_OUT	O	Boost Converter Output. Decouple this pin to PGND with a 10 μF capacitor.
26	VBOOST_IN	I	MICBIAS Regulator Input. Connect this pin to VBOOST_OUT (Pin 25).
27	MICBIAS	O	Microphone Bias Output. Decouple this pin to AGNDx using a 10 μF capacitor.
28	MB_GND	P	Analog Return Ground for the Microphone Bias Regulator. Connect this pin directly to AGNDx for best noise performance.
29	AGND3	P	Analog Ground.
30	VBAT	I	Voltage Sense for Diagnostics. Connect this pin to a load dump suppressed battery voltage. Decouple this to AGNDx using a 0.1 μF capacitor.

<b>Pin No.</b>	<b>Mnemonic</b>	<b>In/Out<sup>1</sup></b>	<b>Description</b>
31	AVDD3	P	Analog Power Supply. Connect this pin to an analog 3.3 V supply.
32	AIN1N	I	Analog Input Channel 1 Inverting Input.
33	AIN1P	I	Analog Input Channel 1 Noninverting Input.
34	AIN2N	I	Analog Input Channel 2 Inverting Input.
35	AIN2P	I	Analog Input Channel 2 Noninverting Input.
36	AIN3N	I	Analog Input Channel 3 Inverting Input.
37	AIN3P	I	Analog Input Channel 3 Noninverting Input.
38	AIN4N	I	Analog Input Channel 4 Inverting Input.
39	AIN4P	I	Analog Input Channel 4 Noninverting Input.
40	AVDD1	P	Analog Power Supply. Connect this pin to an analog 3.3 V supply.
	EP		Exposed Pad. The exposed pad must be connected to the ground plane on the printed circuit board (PCB).

<sup>1</sup> I = input, O = output, I/O = input/output, and P = power.

### TYPICAL PERFORMANCE CHARACTERISTICS

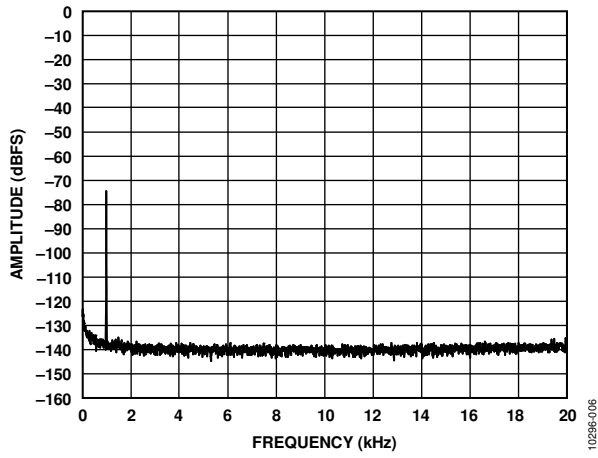

Figure 6. Fast Fourier Transform, 2 mV Differential Input at  $f_s = 48$  kHz

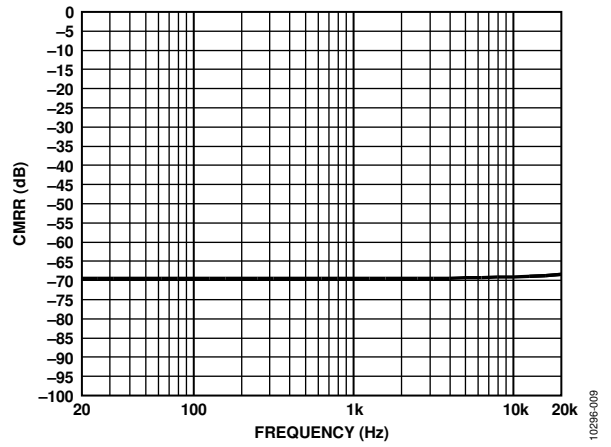

Figure 9. CMRR Differential Input, Referenced to 1 V Differential Input

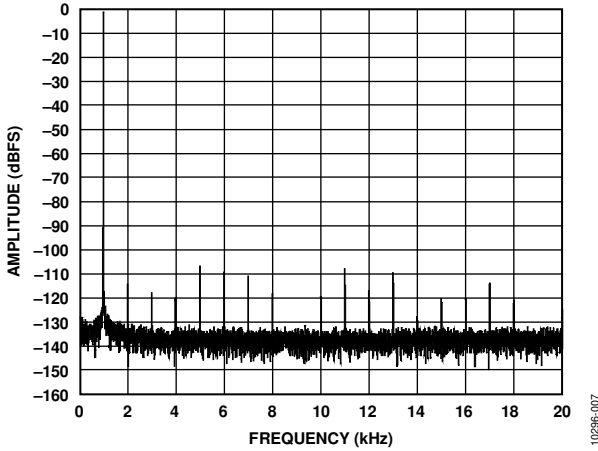

Figure 7. Fast Fourier Transform, -1 dBFS Differential Input

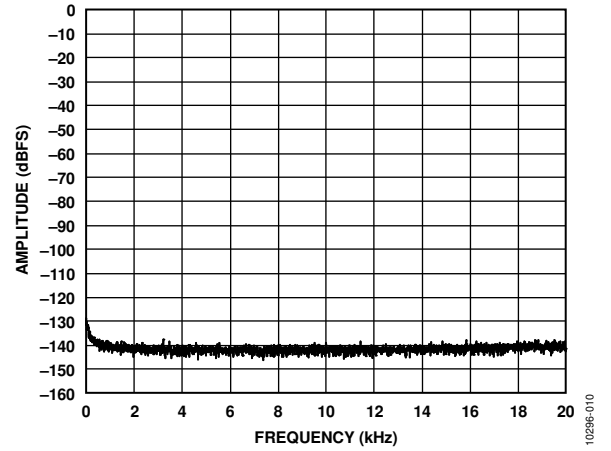

Figure 10. Fast Fourier Transform, No Input

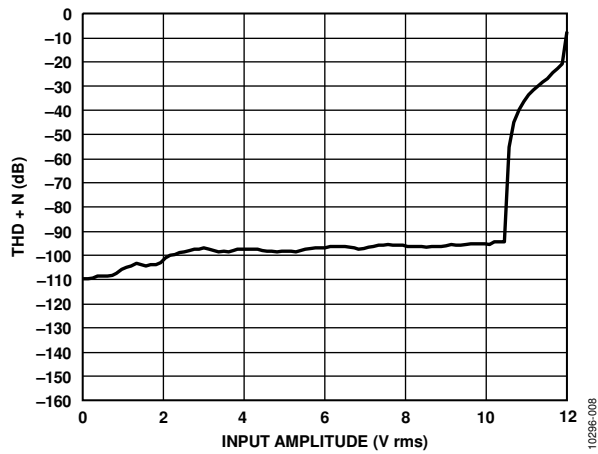

Figure 8. THD + N vs. Input Amplitude

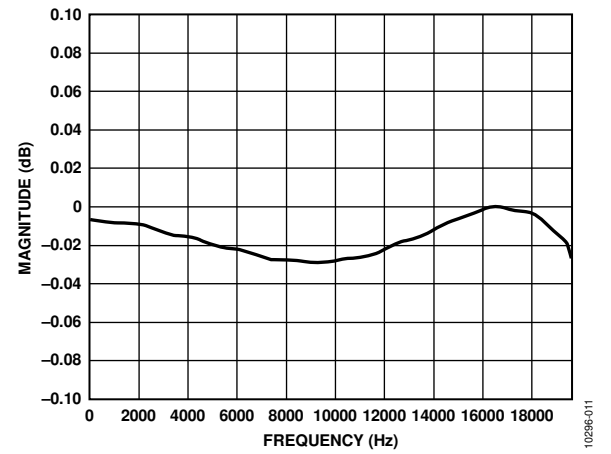

Figure 11. ADC Pass-Band Ripple at  $f_s = 48$  kHz

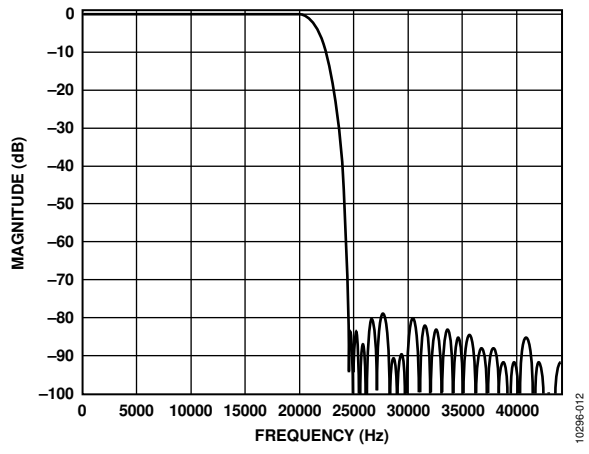

Figure 12. ADC Filter Stop-Band Response at  $f_s = 48$  kHz

## THEORY OF OPERATION

### OVERVIEW

The ADAU1977 incorporates four high performance ADCs with an integrated boost converter for microphone bias, the associated microphone diagnostics for fault detection, and a phase-locked loop circuit for generating the necessary on-chip clock signals.

### POWER SUPPLY AND VOLTAGE REFERENCE

The ADAU1977 requires a single 3.3 V power supply. Separate power supply input pins are provided for the analog and boost converter. These pins should be decoupled to AGND with 100 nF ceramic chip capacitors placed as close as possible to the pins to minimize noise pickup. A bulk aluminum electrolytic capacitor of at least 10  $\mu$ F must be provided on the same PCB as the ADC. It is important that the analog supply be as clean as possible for best performance.

The supply voltage for the digital core (DVDD) is generated using an internal low dropout regulator. The typical DVDD output is 1.8 V and must be decoupled using a 100 nF ceramic capacitor and a 10  $\mu$ F capacitor. Place the 100 nF ceramic capacitor as close as possible to the DVDD pin.

The voltage reference for the analog blocks is generated internally and output at the VREF pin (Pin 2). The typical voltage at the pin is 1.5 V with an AVDDx of 3.3 V.

All digital inputs are compatible with TTL and CMOS levels. All outputs are driven from the IOVDD supply. The IOVDD can be in the range of 1.8 V to 3.3 V. The IOVDD pin must be decoupled with a 100 nF capacitor placed as close to the IOVDD pin as possible. It is recommended to connect the AGND, DGND, PGND, and exposed pad to a single GND plane on the PCB for best performance.

The ADC internal voltage reference is output from the VREF pin and should be decoupled using a 100 nF ceramic capacitor in parallel with a 10  $\mu$ F capacitor. The VREF pin has limited current capability. The voltage reference is used as a reference to the ADC; therefore, it is recommended not to draw current from this pin for external circuits. When using this reference, use a noninverting amplifier buffer to provide a reference to other circuits in the application.

In reset mode, the VREF pin is disabled to save power and is enabled only when the RST pin is pulled high.

### POWER-ON RESET SEQUENCE

The ADAU1977 requires that a single 3.3 V power supply be provided externally at the AVDDx pin. The part internally generates DVDD (1.8 V), which is used for the digital core of the ADC. The DVDD supply output pin (Pin 10) is provided to connect the decoupling capacitors to DGND. The typical recommended values for the decoupling capacitors are 100 nF in parallel with 10  $\mu$ F. During a reset, the DVDD regulator is disabled to reduce power consumption. After the PD/RST pin (Pin 6) is pulled high,

the part enables the DVDD regulator. However, the internal ADC and digital core reset is controlled by the internal  $\overline{\text{POR}}$  signal (power-on reset) circuit, which monitors the DVDD level. Therefore, the device does not come out of a reset until DVDD reaches 1.2 V and the  $\overline{\text{POR}}$  signal is released. The DVDD settling time depends on the charge-up time for the external capacitors and on the AVDDx ramp-up time.

The internal POR circuit is provided with hysteresis to ensure that a reset of the part is not initiated by an instantaneous glitch on DVDD. The typical trip points are 1.2 V with  $\overline{\text{RST}}$  high and 0.6 V ( $\pm 20\%$ ) with  $\overline{\text{RST}}$  low. This ensures that the core is not reset until the DVDD level falls below the 0.6 V trip point.

As soon as the  $\overline{\text{PD/RST}}$  pin is pulled high, the internal regulator starts charging up the  $C_{\text{EXT}}$  on the DVDD pin. The DVDD charge-up time is based on the output resistance of the regulator and the external decoupling capacitor. The time constant can be calculated as

$$t_c = R_{\text{OUT}} \times C_{\text{EXT}} \quad (R_{\text{OUT}} = 20 \Omega \text{ typical})$$

For example, if  $C_{\text{EXT}}$  is 10  $\mu$ F, then  $t_c$  is 200  $\mu$ s and is the time to reach the DVDD voltage, within 63.6%.

The POR circuit releases an internal reset of the core when DVDD reaches 1.2 V (see Figure 13). Therefore, it is recommended to wait for at least the  $t_c$  period to elapse before sending I<sup>2</sup>C or SPI control signals.

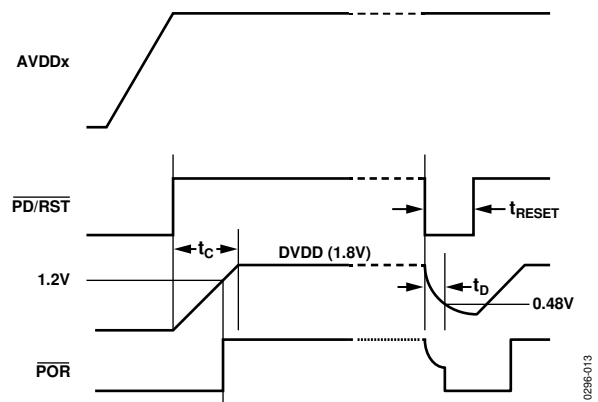

Figure 13. Power-On Reset Timing

When applying a hardware reset to the part by pulling the  $\overline{\text{PD/RST}}$  pin (Pin 6) low and then high, there are certain time restrictions. During the  $\overline{\text{RST}}$  low pulse period, the DVDD starts discharging. The discharge time constant is decided by the internal resistance of the regulator and  $C_{\text{EXT}}$ . The time required for DVDD to fall from 1.8 V to 0.48 V (0.6 V – 20%) can be estimated using the following equation:

$$t_D = 1.32 \times R_{\text{INT}} \times C_{\text{EXT}}$$

where  $R_{\text{INT}} = 64 \text{ k}\Omega$  typical. ( $R_{\text{INT}}$  can vary due to process by  $\pm 20\%$ .)

For example, if  $C_{\text{EXT}}$  is 10  $\mu$ F, then  $t_D$  is 0.845 sec.

Depending on  $C_{EXT}$ ,  $t_D$  may vary and in turn decide the minimum hold period for the  $\overline{RST}$  pulse. The  $\overline{RST}$  pulse must be held low for the  $t_D$  time period to initialize the core properly.

The required  $\overline{RST}$  low pulse period can be reduced by adding a resistor across  $C_{EXT}$ . The new  $t_D$  value can then be calculated as

$$t_D = 1.32 \times R_{EQ} \times C_{EXT}$$

where  $R_{EQ} = 64 \text{ k}\Omega \parallel R_{EXT}$ .

The resistor ensures that DVDD not only discharges quickly during a reset or an AVDDx power loss but also resets the internal blocks correctly. Note that some power loss in this resistor is to be expected because the resistor constantly draws current from DVDD. The typical value for  $C_{EXT}$  is 10  $\mu\text{F}$  and for  $R_{EXT}$  is 3  $\text{k}\Omega$ . This results in a time constant of

$$t_D = 1.32 \times R_{EQ} \times C_{EXT} = 37.8 \text{ ms}$$

where  $R_{EQ} = 2.866 \text{ k}\Omega (64 \text{ k}\Omega \parallel 3 \text{ k}\Omega)$ .

Using this equation at a set  $C_{EXT}$  value, the  $R_{EXT}$  can be calculated for a desired  $\overline{RST}$  pulse period.

There is also a software reset register (S\_RST, Bit 7 of Register 0x00) available that can be used to reset the part, but it must be noted that during an AVDDx power loss, the software reset may not ensure proper initialization because DVDD may not be stable.

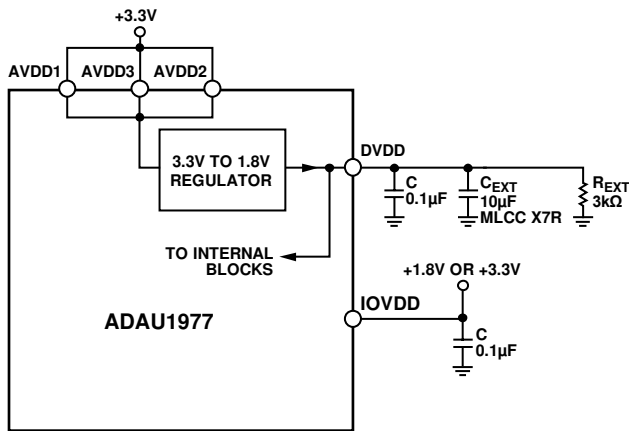

Figure 14. DVDD Regulator Output Connections

### PLL AND CLOCK

The ADAU1977 has a built-in analog PLL to provide a jitter-free master clock to the internal ADC. The PLL must be programmed for the appropriate input clock frequency. The PLL Control Register 0x01 is used for setting the PLL.

The CLK\_S bit (Bit 4) of Register 0x01 is used for setting the clock source for the PLL. The clock source can be either the MCLKIN pin or the LRCLK pin (slave mode). In LRCLK mode, the PLL can support sample rates between 32 kHz and 192 kHz.

In MCLK input mode, the MCS bits (Bits[2:0] of Register 0x01) must be set to the desired input clock frequency for the MCLKIN pin. Table 10 shows the input MCLK required for the most common sample rates and the MCS bit settings.

The PLL\_LOCK bit (Bit 7) of Register 0x01 indicates the lock status of the PLL. It is recommended that after initial power-up the PLL lock status be read to ensure that the PLL outputs the correct frequency before unmuting the audio outputs.

Table 10. Required Input MCLK for Common Sample Rates

MCS (Bits[2:0])	f <sub>s</sub> (kHz)	Frequency Multi- plication Ratio	MCLKIN Frequency (MHz)
000	32	128 × f <sub>s</sub>	4.096
001	32	256 × f <sub>s</sub>	8.192
010	32	384 × f <sub>s</sub>	12.288
011	32	512 × f <sub>s</sub>	16.384
100	32	768 × f <sub>s</sub>	24.576
000	44.1	128 × f <sub>s</sub>	5.6448
001	44.1	256 × f <sub>s</sub>	11.2896
010	44.1	384 × f <sub>s</sub>	16.9344
011	44.1	512 × f <sub>s</sub>	22.5792
100	44.1	768 × f <sub>s</sub>	33.8688
000	48	128 × f <sub>s</sub>	6.144
001	48	256 × f <sub>s</sub>	12.288
010	48	384 × f <sub>s</sub>	18.432
011	48	512 × f <sub>s</sub>	24.576
100	48	768 × f <sub>s</sub>	36.864
000	96	64 × f <sub>s</sub>	6.144
001	96	128 × f <sub>s</sub>	12.288
010	96	192 × f <sub>s</sub>	18.432
011	96	256 × f <sub>s</sub>	24.576
100	96	384 × f <sub>s</sub>	36.864
000	192	32 × f <sub>s</sub>	6.144
001	192	64 × f <sub>s</sub>	12.288
010	192	96 × f <sub>s</sub>	18.432
011	192	128 × f <sub>s</sub>	24.576
100	192	192 × f <sub>s</sub>	36.864

The PLL can accept the audio frame clock (sample rate clock) as input, but the serial port must be configured as a slave and the frame clock must be fed to the part from the master. It is strongly recommended that the PLL be disabled, reprogrammed with the new setting, and then reenabled. A lock bit is provided that can be polled via the I<sup>2</sup>C to check whether the PLL has acquired lock.

The PLL requires an external filter, which is connected at the PLL\_FILT pin (Pin 3). The recommended PLL filter circuit for MCLK or LRCLK mode is shown in Figure 15. Using NPO capacitors is recommended for temperature stability. Place the filter components close to the device for best performance.

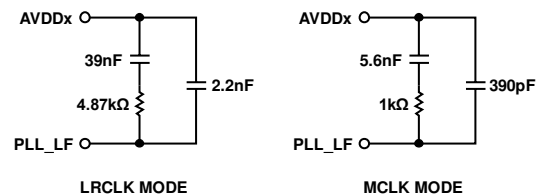

Figure 15. PLL Filter



## DC-TO-DC BOOST CONVERTER

The boost converter generates a supply voltage for the microphone bias circuit from a fixed 3.3 V supply. The boost converter output voltage is programmable using Register 0x03. The boost converter output voltage is approximately 1 V above the set microphone bias voltage. The boost converter uses the clock from the PLL, and the switching frequency is dependent on the sample rate of the ADC. The FS\_RATE bits (Bits[6:5] of Register 0x02) must be set to the desired sample rate. The boost converter switching frequency can be selected to be 1.5 MHz or 3 MHz using Bit 4 of Register 0x02. For the 1.5 MHz switching frequency, the recommended value for the inductor is 4.7  $\mu\text{H}$ , whereas for the 3 MHz switching frequency, the recommended value for the inductor is 2.2  $\mu\text{H}$ .

Table 11 lists the typical switching frequency based on the sample rates.

### Capacitor Selection

The boost converter output is available at the VBOOST\_OUT pin (Pin 25) and must be decoupled to PGND using a 10  $\mu\text{F}$  ceramic capacitor to remove the ripple at the switching frequency. The capacitor must have low ESR and good temperature stability. The MLCC X7R/NPO dielectric type with 25 V is recommended. Care must be taken to place this capacitor as close as possible to the VBOOST\_OUT pin (Pin 25).

**Table 11. Typical Switching Frequency Based on the Sample Rates**

Base Sample Rate (kHz)	Sample Rates (kHz)	Boost Converter Switching Frequency	
		Inductor = 2.2 $\mu\text{H}$	Inductor = 4.7 $\mu\text{H}$
32	8/16/32/64	$(1024/12) \times f_s$	$(1024/22) \times f_s$
44.1	11.025/22.05/44.1/88.2/176.4	$(1024/16) \times f_s$	$(1024/30) \times f_s$
48	12/24/48/96/192	$(1024/16) \times f_s$	$(1024/32) \times f_s$

**MICROPHONE BIAS**

The microphone bias is generated by the input voltage at the VBOOST\_IN pin (Pin 26) via a linear regulator to ensure low noise performance and to reject the high frequency noise from the boost converter. If the internal boost converter output is used, the VBOOST\_OUT pin (Pin 25) must be connected to the VBOOST\_IN pin (Pin 26). If an external supply is used for the microphone bias, the supply can be fed at the VBOOST\_IN pin (Pin 26); in this case, leave the VBOOST\_OUT pin (Pin 25) open. The microphone bias voltage is programmable from 5 V to 9 V by using the MB\_VOLTS bits (Bits[7:4] of Register 0x03). The microphone bias output voltage is available at the MICBIAS pin (Pin 27). This pin can be decoupled to AGND using a maximum of up to a 10 μF capacitor with an ESR of at least 1 Ω. For higher value capacitors, especially those above 1 nF, the ESR of the capacitor should be ≥ 1 Ω to ensure the stability of the microphone bias regulator. Register 0x03 can be used to enable the microphone bias. Table 11 lists the switching frequency of the boost converter based on the inductor value and common sample rates.

**ANALOG INPUTS**

The ADAU1977 has four differential analog inputs. The ADCs can accommodate both dc- and ac-coupled input signals.

The block diagram shown in Figure 16 represents the typical input circuit.

In most audio applications, the dc content of the signal is removed by using a coupling capacitor. However, the ADAU1977 consists of a unique input structure that allows direct coupling of the input signal, eliminating the need for using a large coupling capacitor at the input. Each input has a fixed 14 dB attenuator connected to AGND for accommodating a 10 V rms differential input. The typical input resistance is approximately 26 kΩ from each input to AGND.

In dc-coupled applications, if the V<sub>CM</sub> at AINxP and AINxN is the same, the dc content in the ADC output is close to 0. If the input pins are presented with different common-mode dc levels, the difference between the two levels appears at the ADC output and can be removed by enabling the high-pass filter.

The high-pass filter has a 1.4 Hz, 6 dB per octave cutoff at a 48 kHz sample rate. The cutoff frequency scales directly with the sample frequency. However, care is required in dc-coupled applications to ensure that the common-mode dc voltage does not exceed the specified limit. The common-mode loop can accommodate a common-mode dc voltage from 0 V to 7 V. The input required for the full-scale ADC output (0 dBFS) is typically 10 V rms differential.

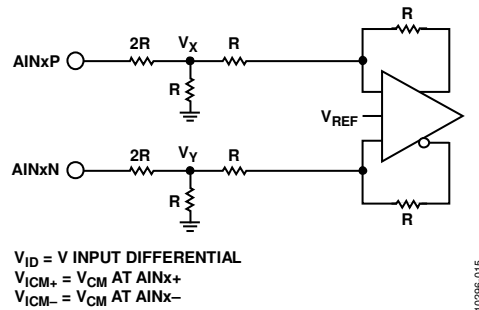

Figure 16. Analog Input Block

### Line Inputs

This section describes some of the possible ways to connect the ADAU1977 for line level inputs.

#### Line Input Balanced or Differential Input DC-Coupled Case

For example, in the case of a typical power amplifier for an automobile, the output can swing around 10 V rms differential with approximately 7.2 V common-mode dc input voltage (assuming a 14.4 V battery and bridge-tied load connection). The signal at each input pin has a 5 V rms or 14.14 V p-p signal swing. With a common-mode dc voltage of 7.2 V, the signal can swing between  $(7.2 \text{ V} + 7.07 \text{ V}) = +14.27 \text{ V}$  p-p and  $(7 \text{ V} - 7.07 \text{ V}) = 0.13 \text{ V}$  at each input. Therefore, this results in approximately a 28.54 V p-p differential signal swing and measures around  $-0.16 \text{ dBFS}$  (ac only with dc high-pass filter) at the ADC output. See Figure 17.

#### Line Input Balanced or Differential Input AC-Coupled Case

For an amplifier output case with ac coupling, refer to Figure 18 for information about connecting the line level inputs to the ADAU1977. In this case, the AINxP/AINxN pins must be pulled up to the required common-mode level using the resistors on MICBIAS. The  $V_{CM}$  must be such that the input never swings below a ground. In other words, if the input signal is 14 V p-p, the  $V_{CM}$  must be around  $14 \text{ V}/2 = 7 \text{ V}$  to ensure that the signal never swings below a ground. The microphone bias can provide the required clean reference for generating the  $V_{CM}$ .

The R1 value can be calculated as follows:

$$R1 = Rin_{1977} (MB - V_{CM}) / V_{CM}$$

where:

$V_{CM}$  is the peak-to-peak input swing divided by 2.

$MB = 8.5 \text{ V}$ .

$Rin_{1977}$  is the single-ended input resistance (see Table 1).

However, in this case the equivalent input resistance of AINxP/AINxN is reduced and can be calculated as  $R1 \parallel Rin_{1977}$ .

$$\text{Input Resistance} = R1 \times Rin_{1977} / (R1 + Rin_{1977})$$

where  $Rin_{1977}$  is the single-ended value from Table 1.

The C1 and C2 values can be determined for the required low frequency cutoff using the following equation:

$$C1 \text{ or } C2 = 1 / (2 \times \pi \times f_c \times \text{Input Resistance})$$

#### Line Input Unbalanced or Single-Ended Pseudo Differential AC-Coupled Case

For a single-ended application, the signal swing is reduced by half because only one input is used for the signal, and the other input is connected to 0 V. As a result, the input signal capability is reduced to 5 V rms in a single-ended application. With a common-mode dc voltage of 7.2 V, the signal can swing between  $(7.2 \text{ V} + 7.07 \text{ V}) = +14.27 \text{ V}$  p-p and  $(7.2 \text{ V} - 7 \text{ V}) = 0.13 \text{ V}$ . Therefore, this results in approximately a 14.14 V p-p differential signal swing and measures around  $-6.16 \text{ dBFS}$  (ac only with dc high-pass filter) at the ADC output. See Figure 19.

The values of the resistors (R1/R2) and capacitors (C1/C2) are similar to those for the balanced ac-coupled case described in the Line Input Balanced or Differential Input AC-Coupled Case section.

#### Line Input Unbalanced or Single-Ended AC-Coupled Case

For a single-ended application, the signal swing is reduced by half because only one input is used for the signal, and the other input is connected to 0 V. As a result, the input signal capability is reduced to 5 V rms in a single-ended application. With a common-mode dc voltage of 7.2 V, the signal can swing between  $(7.2 \text{ V} + 7.07 \text{ V}) = +14.27 \text{ V}$  p-p and  $(7.2 \text{ V} - 7 \text{ V}) = 0.13 \text{ V}$ . Therefore, this results in approximately a 14.14 V p-p differential signal swing and measures around  $-6.16 \text{ dBFS}$  (ac only with dc high-pass filter) at the ADC output. The difference in the common-mode dc voltage between the positive and negative input (7.2 V) would appear at the ADC output if the signal was not high-pass filtered. See Figure 20.

The values of the resistor (R1) and capacitor (C1) are similar to those for the balanced ac-coupled case described in the Line Input Balanced or Differential Input AC-Coupled Case section.

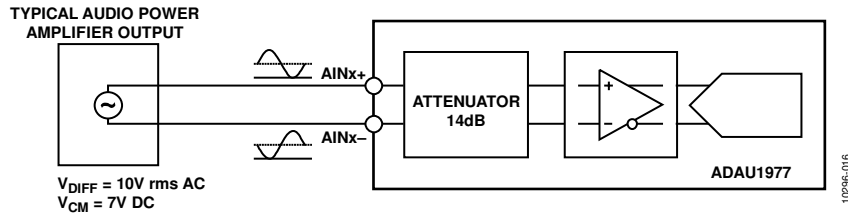

Figure 17. Connecting the Line Level Inputs—Differential DC-Coupled Case

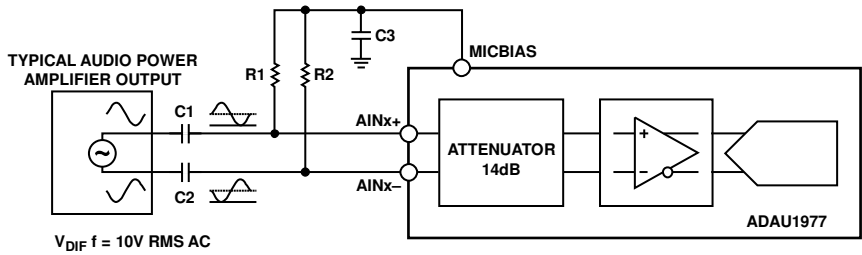

Figure 18. Connecting the Line Level Inputs—Differential AC-Coupled Case

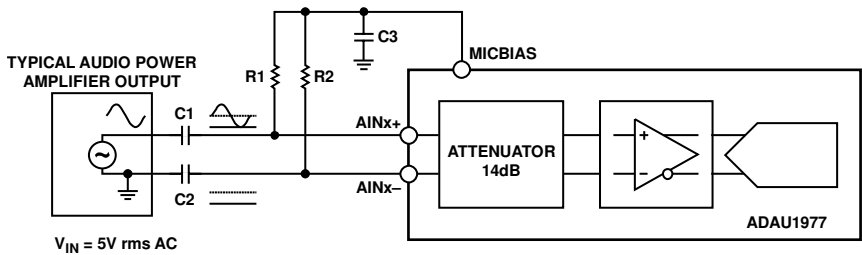

Figure 19. Connecting the Line Level Inputs—Pseudo Differential AC-Coupled Case

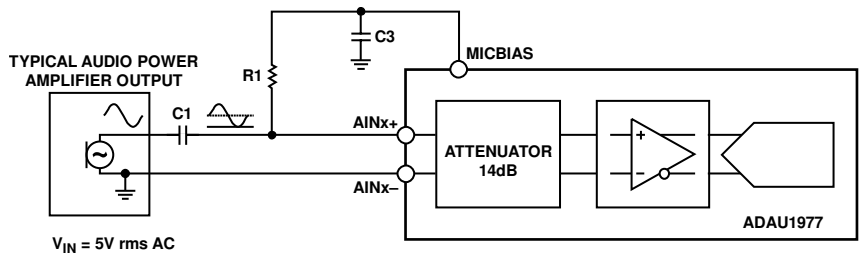

Figure 20. Connecting the Line Level Inputs—Single-Ended AC-Coupled Case

**Microphone Inputs**

This section describes some ways to connect the ADAU1977 for microphone input applications. The MICBIAS voltage and the bias resistor value depend on the ECM selected. The ADAU1977 can provide the MICBIAS from 5 V up to 9 V in 0.5 V steps. In an application requiring multiple microphones, care must be taken not to exceed the MICBIAS output current rating.

**ECM Balanced or Differential Input DC-Coupled Case**

For example, in a typical ECM, the output signal swing depends on the MICBIAS voltage. With a typical 8.5 V supply, the ECM can output a 2 V rms differential signal. The signal at each input pin has a 1 V rms or 2.8 V p-p signal swing. With a common-mode dc

level of  $2/3 \times \text{MICBIAS}$  on the AINxP and  $1/3 \times \text{MICBIAS}$  on the AINxN pins, this results in around -14 dBFS (ac only with dc high-pass filter) at the ADC output because the input is 14 dB below the full-scale input of 10 V rms differential. See Figure 21.

**ECM Pseudo Differential Input AC-Coupled Case**

For a typical MEMS ECM module, the output signal swing is low. With a typical 3.3 V supply, the ECM module can output a 2 V rms differential signal. The signal at the input pin has a 1 V rms or 2.8 V p-p signal swing. For this application, it is recommended to bias the input pins using resistors to 7 V dc, similar to the case described in the Line Input Unbalanced or Single-Ended Pseudo Differential AC-Coupled Case section. See Figure 22.

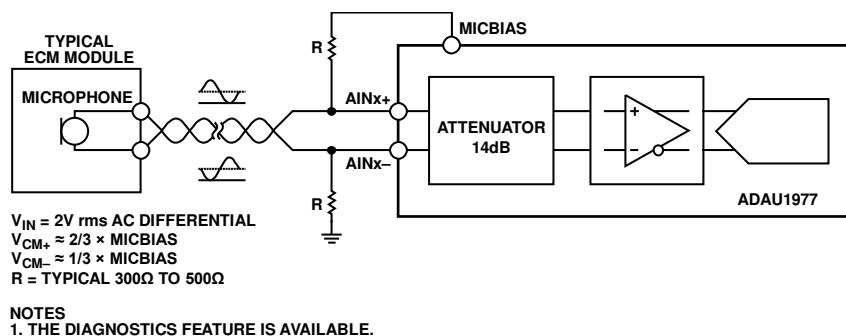

Figure 21. Connecting the Microphone Inputs—Differential Input DC-Coupled Case

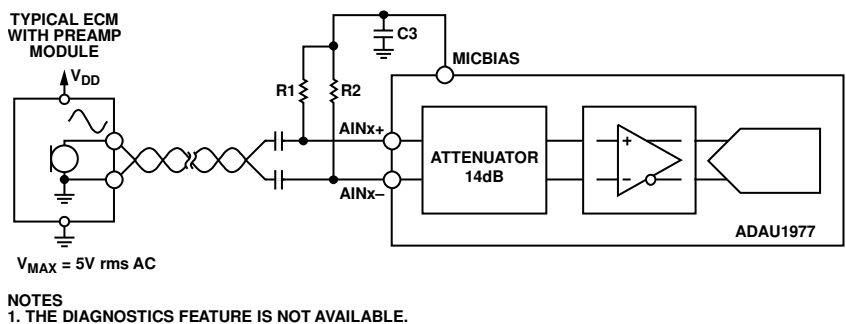

Figure 22. Connecting the Microphone Inputs—Pseudo Differential Input AC-Coupled Case

**ADC**

The ADAU1977 contains four  $\Delta$ - $\Sigma$  ADC channels configured as two stereo pairs with configurable differential/single-ended inputs. The ADC can operate at a nominal sample rate of 32 kHz up to 192 kHz. The ADCs include on-board digital antialiasing filters with 79 dB stop-band attenuation and linear phase response. Digital outputs are supplied through two serial data output pins (one for each stereo pair) and a common frame clock (LRCLK) and bit clock (BCLK). Alternatively, one of the TDM modes can be used to support up to 16 channels on a single TDM data line.

With smaller amplitude input signals, a 10-bit programmable digital gain compensation for an individual channel is provided to scale up the output word to full scale. Care must be taken to avoid overcompensation (large gain compensation), which leads to clipping and THD degradation in the ADC.

The ADCs also have a dc-offset calibration algorithm to null the systematic dc offset of the ADC. This feature is useful for dc measurement applications.

**Inductor Selection**

For the boost converter to operate efficiently, the inductor selection is critical. The two most important parameters for the inductor are the saturation current rating and the dc resistance. The recommended saturation rating for the inductor must be >1 A. The dc resistance affects the efficiency of the boost converter. Assuming that the board trace resistances are negligible for 80% efficiency, the dc resistance of the inductor should be less than 50 m $\Omega$ .

Table 12 lists some of the recommended inductors for the application.

**Table 12. Recommended Inductors<sup>1</sup>**

Value	Manufacturer	Manufacturer Part Number
2.2 $\mu$ H	Würth Elektronik	7440430022
4.7 $\mu$ H	Würth Elektronik	7440530047

<sup>1</sup> Check with the manufacturer for the appropriate temperature ratings for a given application.

The boost converter has a soft start feature that prevents inrush current from the input source.

The boost converter has built-in overcurrent and overtemperature protection. The input current to the boost converter is monitored and if it exceeds the set current threshold for 1.2 ms, the boost converter shuts down. The fault condition is recorded into Register 0x02 and asserts the fault interrupt pin. This condition is cleared after reading the BOOST\_OV bit (Bit 2) or the BOOST\_OC bit (Bit 0) in Register 0x02. The overcurrent protection bit, OC\_EN (Bit 1), or the overvoltage protection bit, OV\_EN (Bit 3), is on by default, and it is recommended not to disable the bit.

Each protection circuit has two modes for recovery after a fault event: autorecovery and manual recovery. The recovery mode can be selected using Bit 0 of Register 0x03. The autorecovery mode attempts to enable the boost converter after a set recovery time, typically 20 ms. The manual recovery mode enables the boost converter only if the user writes 1 to the MRCV bit (Bit 1). If the fault persists, the boost converter remains in shutdown mode until the fault is cleared.

The boost converter is capable of supplying the 42 mA of total output current at the MICBIAS output. The boost converter has overcurrent protection at the input; the threshold is around 900 mA peak. Ensure that the 3.3 V power supply feeding the boost converter has built-in overcurrent protection because there is no protection internal to ADAU1977 for a short circuit to any of the ground pins (AGND/DGND/PGND) at the VBOOST\_OUT or VBOOST\_IN pin.

By default, the boost converter is disabled on power-up to allow the flexibility of connecting an external voltage source at the VBOOST\_IN pin to power the microphone bias circuit. The boost converter can be enabled by using the BOOST\_EN bit (Bit 2 of Register 0x03).

**ADC SUMMING MODES**

The four ADCs can be grouped into either a single stereo ADC or a single mono ADC to increase the signal-to-noise ratio (SNR) for the application. Two options are available: one option for summing two channels of the ADC and another option for summing all four channels of the ADC. Summing is performed in the digital block.

**2-Channel Summing Mode**

When the SUM\_MODE Bits (Bits[7:6] of Register 0x0E) are set to 01, the Channel 1 and Channel 2 ADC data are combined and output from the SDATAOUT1 pin. Similarly, the Channel 3 and Channel 4 ADC data are combined and output from the SDATAOUT2 pin. As a result, the SNR improves by 3 dB. For this mode, both Channel 1 and Channel 2 must be connected to the same input signal source. Similarly, Channel 3 and Channel 4 must be connected to the same input signal source.

**4-Channel Summing Mode**

When the SUM\_MODE Bits (Bits[7:6] of Register 0x0E) are set to 10, the Channel 1 through Channel 4 ADC data are combined and output from the SDATAOUT1 pin. As a result, the SNR improves by 6 dB. For this mode, all four channels must be connected to the same input signal source.

## DIAGNOSTICS

The diagnostics block monitors the input pins in real time and reports a fault as an interrupt signal on the FAULT pin (Pin 8), which triggers sending an interrupt request to an external controller. The diagnostics status registers (Register 0x11 through Register 0x14) for Channel 1 through Channel 4 are also updated. Refer to the register map table (Table 25) and the register details tables (Table 42, Table 43, Table 44, and Table 45) for more information about the diagnostics register content. The diagnostics can be enabled or disabled for each channel using Bits[3:0] of Register 0x10. The diagnostics are provided only when MICBIAS is enabled and the microphone is connected as recommended in the appropriate application circuit (see Figure 21).

### Diagnostics Reporting

The diagnostics status is reported individually for each channel in Register 0x11 through Register 0x14. The faults listed in Table 13 are reported on each input pin.

**Table 13. Faults Reported**

Fault	AINxP	AINxN
Short to Battery	Yes	Yes
Short to MICBIAS	Yes	No
Short to Ground	Yes	Yes
Short Between Positive and Negative Inputs	Yes	Yes
Open Input	Yes	Yes

### Diagnostics Adjustments

#### Short Circuit to Battery Supply

When an input terminal is shorted to the battery, the voltage at the terminal approaches the battery voltage. Any voltage higher than the set threshold is reported as a fault. The threshold can be set using the SHT\_B\_TRIP bits, Bits[1:0] of Register 0x17 (see Table 14).

**Table 14. Setting the Short to Battery Threshold**

SHT_B_TRIP (Register 0x17, Bits[1:0])	Short to Battery Threshold
00	$0.95 \times \text{VBAT}$
01	$0.9 \times \text{VBAT}$
10	$0.85 \times \text{VBAT}$
11	$0.975 \times \text{VBAT}$

#### Short Circuit to MICBIAS

This feature is supported only on the AINxP terminal. When an AINxP terminal is shorted to MICBIAS, the voltage at the AINxP terminal approaches the MICBIAS voltage. Any voltage higher than the set threshold is reported as a fault. The threshold can be set using the SHT\_M\_TRIP bits, Bits[5:4] of Register 0x17 (see Table 15).

**Table 15. Setting the Short to MICBIAS Threshold**

SHT_M_TRIP (Register 0x17, Bits[5:4])	Short to MICBIAS Threshold
00	$0.95 \times \text{MICBIAS}$
01	$0.9 \times \text{MICBIAS}$
10	$0.85 \times \text{MICBIAS}$
11	$0.975 \times \text{MICBIAS}$

#### Short Circuit to Ground

When an input terminal is shorted to ground, the terminal voltage reaches close to 0 V. Any voltage lower than the set threshold is reported as a fault. The threshold is referenced to VREF and, therefore, scales with the voltage at the VREF pin. The threshold can be set using the SHT\_G\_TRIP bits, Bits[3:2] of Register 0x17 (see Table 16).

**Table 16.**

SHT_G_TRIP (Register 0x17, Bits[3:2])	Short to Ground Threshold
00	$0.2 \times \text{VREF}$
01	$0.133 \times \text{VREF}$
10	$0.1 \times \text{VREF}$
11	$0.266 \times \text{VREF}$

#### Microphone Terminal Short Circuited

When both input terminals are shorted, both the AINxP and AINxN input terminals are at the same voltage—around MICBIAS/2. Any voltage between the set thresholds is reported as a fault. The upper and lower threshold voltages can be set using the SHT\_T\_TRIP bits, Bits[7:6] of Register 0x17 (see Table 17).

The following equations can be used to calculate the upper and lower thresholds:

$$\text{Upper Threshold} = \text{MICBIAS}(0.5 + x)$$

$$\text{Lower Threshold} = \text{MICBIAS}(0.5 - x)$$

where  $x$  can be set using the SHT\_T\_TRIP bits, Bits[7:6] of Register 0x17 (see Table 17).

**Table 17.**

SHT_T_TRIP (Register 0x17, Bits [7:6])	x
00	0.035
01	0.017
10	0.071
11	Reserved

**Microphone Terminals Open**

In the event that any of the input terminals becomes open circuited, AINxP is pulled to MICBIAS and AINxN is pulled to a common ground. When the AINxP terminal is at a voltage that is higher than the short to the MICBIAS threshold (set using Bits[5:4] of Register 0x17) and the AINxN terminal voltage is at a voltage that is less than the short to the ground threshold (set using Bits[3:2] of Register 0x17), a fault is reported. The fault cannot indicate which terminal is open circuited because any terminal that is open circuited pulls AINxP to MICBIAS and AINxN to a common ground.

**FAULT Pin**

The FAULT pin is an output pin that can be programmed to be active high or active low logic using the IRQ\_POL bit (Bit 4 of Register 0x15). In addition, the FAULT pin can be set using the IRQ\_DRIVE bit (Bit 5 of Register 0x15) to drive always or to drive only during a fault and is otherwise set to high-Z. The fault status is registered in the IRQ\_RESET bit (Bit 6 of Register 0x15). The IRQ\_RESET bit is a latched bit and is set in the event of a fault and cleared only after the fault status bit is read.

**Fault Timeout**

To prevent the false triggering of a fault event, the fault timeout adjust bits (Bits[5:4] of Register 0x18) are provided. These bits can be used to set the time that the fault needs to persist before

being reported. The timeout can be set to 0 ms, 50 ms, 100 ms, or 150 ms using the FAULT\_TO bits (Bits[5:4] of Register 0x18). The default value is 100 ms. A fault is recorded only if the condition persists for more than a set minimum timeout.

**Fault Masking**

The faults can be masked to prevent triggering an interrupt on the FAULT pin. Fault masking can be set using Bits[6:0] of Register 0x16. The mask can be set for the faults listed in Table 18.

**Table 18. Fault Masking**

Fault	AINxP	AINxN
Short to Battery	Yes	Yes
Short to MICBIAS	Yes	No
Short to Ground	Yes	Yes
Short Between Positive and Negative Inputs	Yes	Yes
Open Input	Yes	Yes

When a fault mask bit is set, it is applied to all the channels. There is no individual fault mask available per channel using this bit. To mask individual channels, use the DIAG\_MASK[4:1] bits (Bits[3:0] of Register 0x15).

**Diagnostics Sequence**

The sequence shown in Figure 23 is recommended for reading the faults reported by diagnostics.

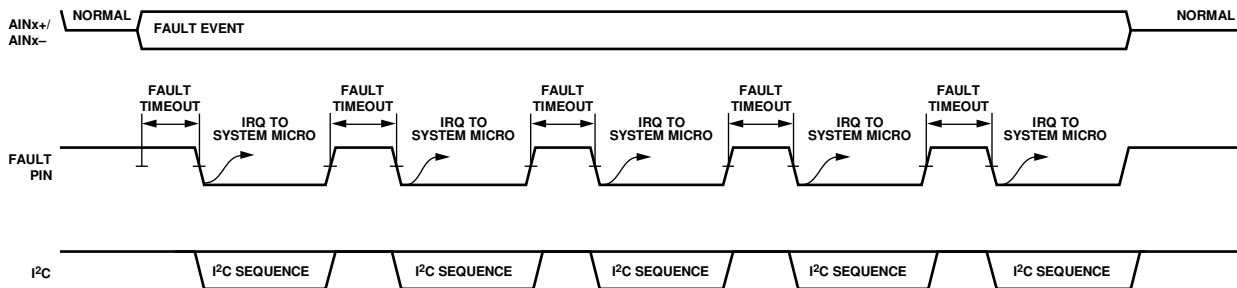

Figure 23. Diagnostics Sequence

10296-023



In the event of a fault on an input pin, the FAULT pin goes low or high depending on the setting of the IRQ\_POL bit in Register 0x15 to send an interrupt request to the system microcontroller. The system microcontroller responds to the interrupt request by communicating with the ADAU1977 via the I<sup>2</sup>C.

The following is the typical interrupt service routine:

1. An interrupt request is generated from the ADAU1977 to the system microcontroller.
2. Read Register 0x11 through Register 0x14. (It is recommended to read all four diagnostics status registers—Register 0x11 through Register 0x14—in one sequence. Reading the registers as a single read may not report the status accurately.)
3. Write Register 0x15, Bit 6 (the IRQ\_RESET bit).
4. Wait for the fault timeout period to expire.
5. If the fault was temporary and did not persist, the interrupt service ends and the intermittent fault is ignored. If the fault persists, another interrupt request is generated from the ADAU1977, and the user should continue on to Step 6.
6. Repeat Step 2 through Step 4 four times.

7. If after the fifth reading, the diagnostics still report the presence of a fault, the fault exists on the respective input and must be attended to.

### SERIAL AUDIO DATA OUTPUT PORTS—DATA FORMAT

The serial audio port comprises four pins: BCLK, LRCLK, SDATAOUT1, and SDATAOUT2. The ADAU1977 ADC outputs are available on the SDATAOUT1 and SDATAOUT2 pins in serial format. The BCLK and LRCLK pins serve as the bit clock and frame clock, respectively. The port can be operated as master or slave and can be set either in stereo mode (2-channel mode) or in TDM multichannel mode. The supported popular audio formats are I<sup>2</sup>S, left justified (LJ), right justified (RJ).

#### Stereo Mode

In 2-channel or stereo mode, the SDATAOUT1 outputs ADC data for Channel 1 and Channel 2, and the SDATAOUT2 outputs ADC data for Channel 3 and Channel 4. Figure 24 through Figure 28 show the supported audio formats.

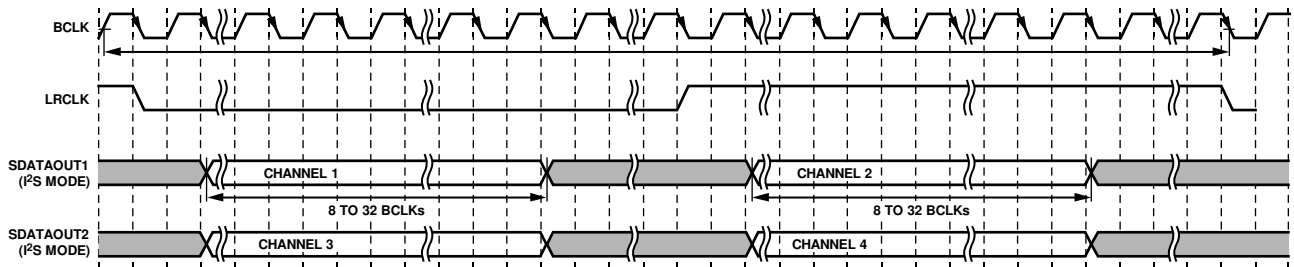

- NOTES  
 1. SAI = 0.  
 2. SDATA\_FMT = 0 (I<sup>2</sup>S).

Figure 24. I<sup>2</sup>S Audio Format

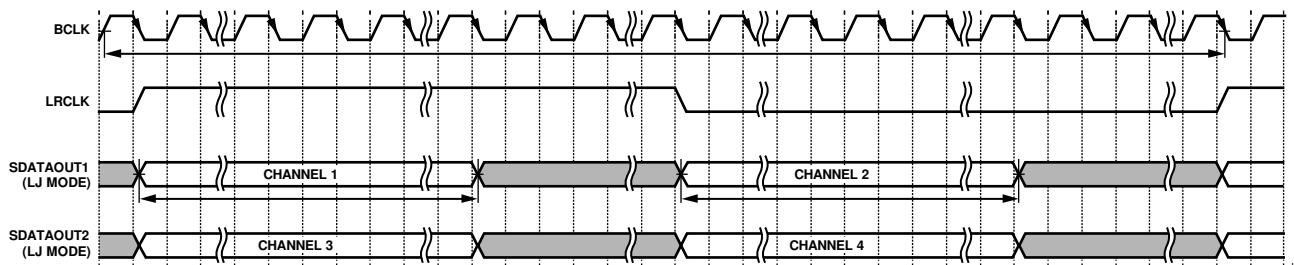

- NOTES  
 1. SDATA\_FMT = 1 (LJ).

Figure 25. LJ Audio Format

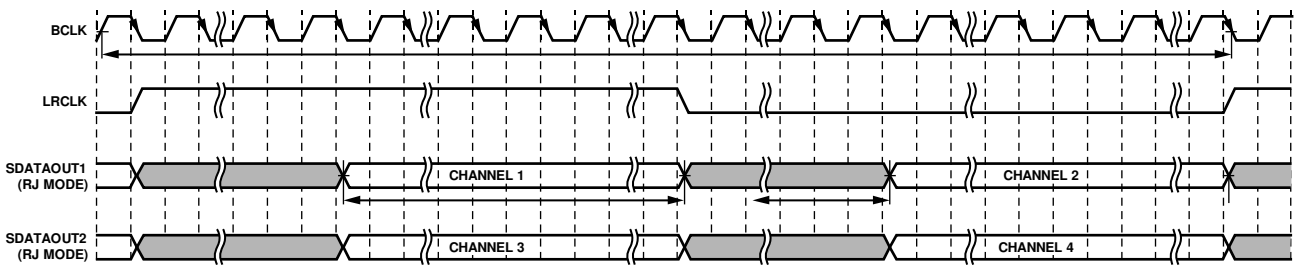

- NOTES  
 1. SDATA\_FMT = 2 (RJ, 24-BIT).

Figure 26. RJ Audio Format

**TDM Mode**

Register 0x05 through Register 0x08 provide programmability for the TDM mode. The TDM slot width, data width, and channel assignment, as well as the pin used to output the data, are programmable.

By default, serial data is output on the SDATAOUT1 pin; however, the SDATA\_SEL bit (Bit 7 of Register 0x06) can be used to change the setting so that serial data is output from the SDATAOUT2 pin.

The TDM mode supports 2, 4, 8, or 16 channels. The ADAU1977 outputs four channels of data in the assigned slots (Figure 29 shows the data slot assignments). During the unused slots, the

output pin goes high-Z so that the same data line can be shared with other devices on the TDM bus.

The TDM port can be operated as either a master or a slave. In master mode, the BCLK and LRCLK are output from the ADAU1977, whereas in slave mode, the BCLK and LRCLK pins are set to receive the clock from the master in the system.

Both the nonpulse and pulse modes are supported. In nonpulse mode, the LRCLK signal is typically 50% of the duty cycle, whereas in pulse mode, the LRCLK signal must be at least one BCLK wide (see Figure 27 and Figure 28).

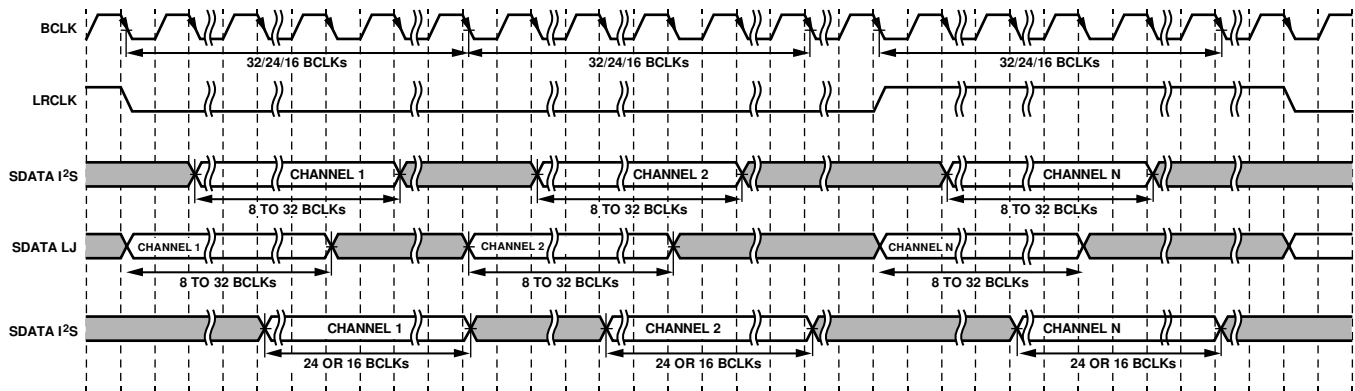

- NOTES
1. SAI = 001 (2 CHANNELS), 010 (4 CHANNELS), 011 (8 CHANNELS), 100 (16 CHANNELS).
  2. SDATA\_FMT = 00 (I²S), 01 (LJ), 10 (RJ, 24-BIT), 11 (RJ, 16-BIT).
  3. BCLK\_EDGE = 0.
  4. LRCLK\_MODE = 0.
  5. SLOT\_WIDTH = 00 (32 BCLKs), 01 (24 BCLKs), 10 (16 BCLKs).

Figure 27. TDM Nonpulse Mode Audio Format

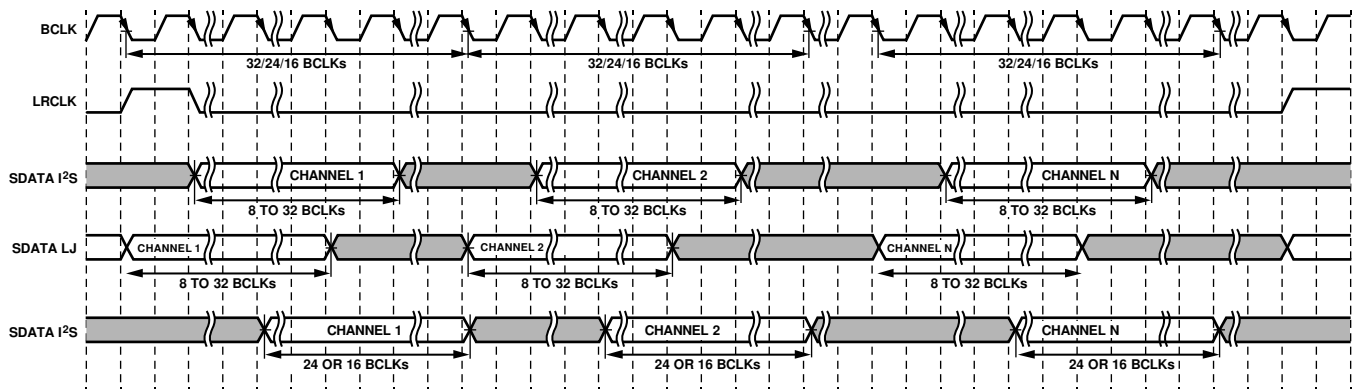

- NOTES
1. SAI = 001 (2 CHANNELS), 010 (4 CHANNELS), 011 (8 CHANNELS), 100 (16 CHANNELS).
  2. SDATA\_FMT = 00 (I²S), 01 (LJ), 10 (RJ, 24-BIT), 11 (RJ, 16-BIT).
  3. BCLK\_EDGE = 0.
  4. LRCLK\_MODE = 1.
  5. SLOT\_WIDTH = 00 (32 BCLKs), 01 (24 BCLKs), 10 (16 BCLKs).

Figure 28. TDM Pulse Mode Audio Format

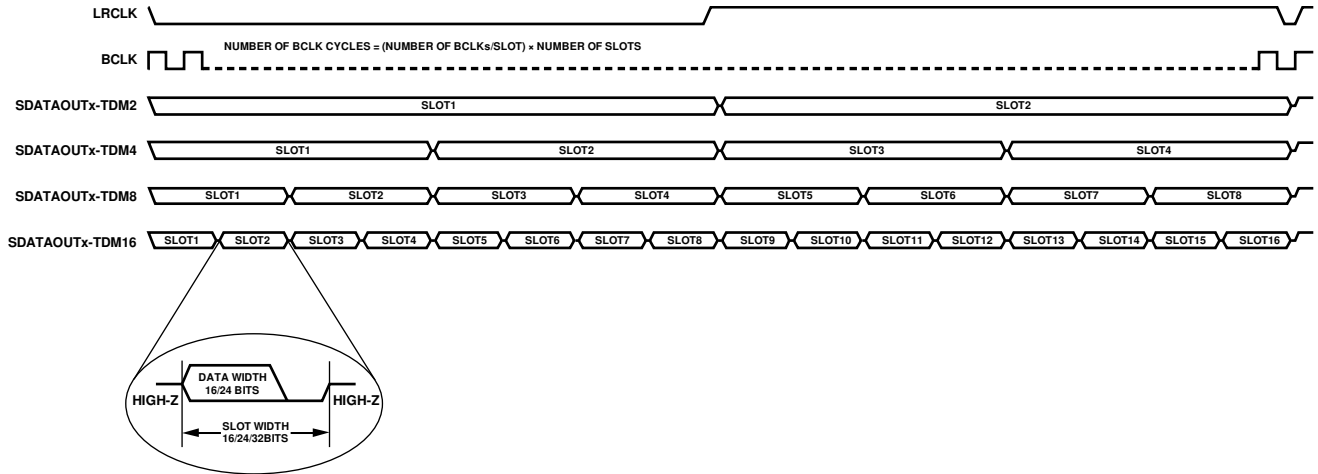

Figure 29. TDM Mode Slot Assignment

10296-029

The bit clock frequency depends on the sample rate, the slot width, and the number of bit clocks per slot. Table 19 can be used to calculate the BCLK frequency.

The sample rate ( $f_s$ ) can range from 8 kHz up to 192 kHz. However, in master mode, the maximum bit clock frequency (BCLK) is 24.576 MHz. For example, for a sample rate of 192 kHz,  $128 \times f_s$  is the maximum possible BCLK frequency. Therefore, only 128 bit clock cycles are available per TDM frame. There are two options in this case: either operate with a 32-bit data width in TDM4 or operate with a 16-bit data width in TDM8. In slave mode, this limitation does not exist because the bit clock and frame clock are fed to the ADAU1977. Various combinations of BCLK frequency and mode are available, but

care must be taken to choose the combination that is most suitable for the application.

**Connection Options**

Figure 30 through Figure 34 show the available options for connecting the serial audio port in I<sup>2</sup>S or TDM mode. In TDM mode, it is recommended to include the pull-down resistor on the data signal to prevent the line from floating when the SDATAOUTx pin of ADAU1977 goes high-Z during an inactive period. The resistor value should be such that no more than 2 mA is drawn from the SDATAOUTx pin. Although the resistor value is typically in the range of 10 kΩ to 47 kΩ, the appropriate resistor value depends on the devices on the data bus.

**Table 19. Bit Clock Frequency TDM Mode**

Mode	BCLK Frequency		
	16 Bit Clocks Per Slot	24 Bit Clocks Per Slot	32 Bit Clocks Per Slot
TDM2	$32 \times f_s$	$48 \times f_s$	$64 \times f_s$
TDM4	$64 \times f_s$	$96 \times f_s$	$128 \times f_s$
TDM8	$128 \times f_s$	$192 \times f_s$	$256 \times f_s$
TDM16	$256 \times f_s$	$384 \times f_s$	$512 \times f_s$

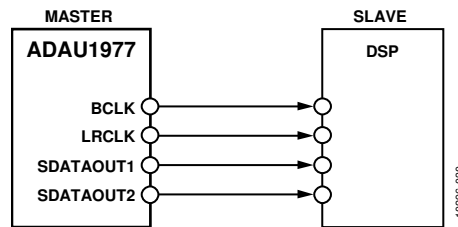

Figure 30. Serial Port Connection Option 1—I<sup>2</sup>S/LJ/RJ Mode, ADAU1977 Master

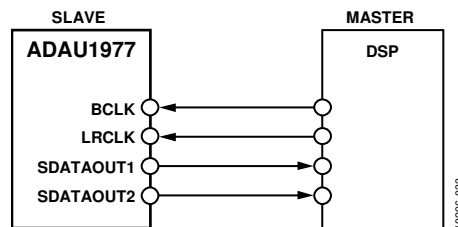
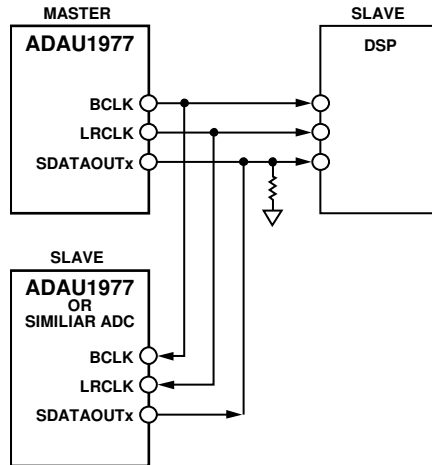
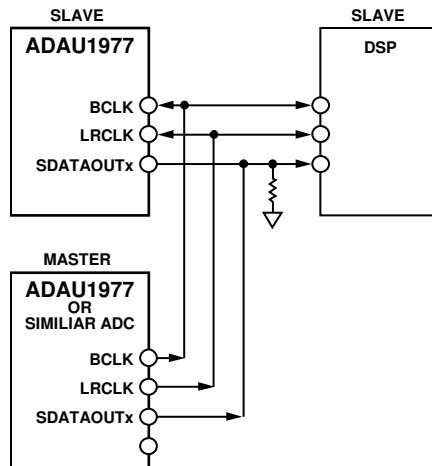

Figure 31. Serial Port Connection Option 2—I<sup>2</sup>S/LJ/RJ Mode, ADAU1977 Slave



10296-031

Figure 32. Serial Port Connection Option 3—TDM Mode, ADAU1977 Master



10296-034

Figure 33. Serial Port Connection Option 4—TDM Mode, Second ADC Master

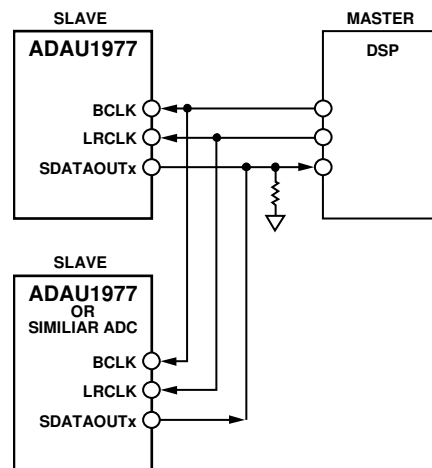

10296-032

Figure 34. Serial Port Connection Option 5—TDM Mode, DSP Master

## CONTROL PORTS

The ADAU1977 control port allows two modes of operation—either 2-wire I<sup>2</sup>C mode or 4-wire SPI mode—that are used for setting the internal registers of the part. Both the I<sup>2</sup>C and SPI modes allow read and write capability of the registers. All the registers are eight bits wide. The registers start at Address 0x00 and end at Address 0x1A.

The control port in both I<sup>2</sup>C and SPI modes is slave only and, therefore, requires the master in the system to operate. The registers can be accessed with or without the master clock to the part.

However, to operate the PLL, serial audio ports, and boost converter, the master clock is necessary.

By default, the ADAU1977 operates in I<sup>2</sup>C mode, but the part can be put into SPI mode by pulling the  $\overline{\text{CLATCH}}$  pin low three times.

The control port pins are multifunctional, depending on the mode in which the part is operating. Table 20 describes the control port pin functions in both modes.

**Table 20. Control Port Pin Functions**

Pin No.	Pin Name	I <sup>2</sup> C Mode		SPI Mode	
		Pin Functions	Pin Type	Pin Functions	Pin Type
17	SDA/COUT	SDA: data	I/O	COUT: output data	O
18	SCL/CCLK	SCL: clock	I	CCLK: input clock	I
19	ADDR0/ $\overline{\text{CLATCH}}$	I <sup>2</sup> C Device Address Bit 0	I	$\overline{\text{CLATCH}}$ : input	I
20	ADDR1/CIN	I <sup>2</sup> C Device Address Bit 1	I	CIN: input data	I

## I<sup>2</sup>C MODE

The ADAU1977 supports a 2-wire serial (I<sup>2</sup>C-compatible) bus protocol. Two pins—serial data (SDA) and serial clock (SCL)—are used to communicate with the system I<sup>2</sup>C master controller. In I<sup>2</sup>C mode, the ADAU1977 is always a slave on the bus, meaning that it cannot initiate a data transfer. Each slave device on the I<sup>2</sup>C bus is recognized by a unique device address. The device address and R/W byte for the ADAU1977 are shown in Table 21. The address resides in the first seven bits of the I<sup>2</sup>C write. Bit 7 and Bit 6 of the I<sup>2</sup>C address for the ADAU1977 are set by the levels on the ADDR1 and ADDR0 pins. The LSB of the first I<sup>2</sup>C byte (the R/W bit) from the master identifies whether it is a read or write operation. Logic Level 1 in LSB corresponds to a read operation, and Logic Level 0 corresponds to a write operation.

**Table 21. ADAU1977 I<sup>2</sup>C First Byte Format**

Bit 7	Bit 6	Bit 5	Bit 4	Bit 3	Bit 2	Bit 1	Bit 0
ADDR1	ADDR0	1	0	0	0	1	R/W

The first seven bits of the I<sup>2</sup>C chip address for the ADAU1977 are xx10001. Bit 0 and Bit 1 of the address byte can be set using the ADDR1 and ADDR0 pins to set the chip address to the desired value.

The 7-bit I<sup>2</sup>C device address can be set to one of four possible options using the ADDR1 and ADDR0 pins:

- I<sup>2</sup>C Device Address 0010001 (0x11)
- I<sup>2</sup>C Device Address 0110001 (0x31)
- I<sup>2</sup>C Device Address 1010001 (0x51)
- I<sup>2</sup>C Device Address 1110001 (0x71)

In I<sup>2</sup>C mode, both the SDA and SCL pins require that an appropriate pull-up resistor be connected to IOVDD. The voltage on these signal lines should not exceed the voltage on the IOVDD pin. Figure 46 shows a typical connection diagram for the I<sup>2</sup>C mode.

The value of the pull-up resistor for the SDA or SCL pin can be calculated as follows.

$$\text{Minimum } R_{PULL\ UP} = (IOVDD - V_{IL})/I_{SINK}$$

where:

IOVDD is the I/O supply voltage, typically ranging from 1.8 V up to 3.3 V.

$V_{IL}$  is the maximum voltage at Logic Level 0 (that is, 0.4 V, as per the I<sup>2</sup>C specifications).

$I_{SINK}$  is the current sink capability of the I/O pin.

The SDA pin can sink 2 mA current; therefore, the minimum value of  $R_{PULL\ UP}$  for an IOVDD of 3.3 V is 1.5 k $\Omega$ .

Depending on the capacitance of the board, the speed of the bus can be restricted to meet the rise time and fall time specifications.

For fast mode with a bit rate time of around 1 Mbps, the rise time must be less than 550 ns. Use the following equation to determine whether the rise time specification can be met:

$$t = 0.8473 \times R_{PULL\ UP} \times C_{BOARD}$$

To meet the 300 ns rise time requirement, the  $C_{BOARD}$  must be less than 236 pF.

For the SCL pin, the calculations depend on the current sink capability of the I<sup>2</sup>C master used in the system.

## Addressing

Initially, each device on the I<sup>2</sup>C bus is in an idle state and monitors the SDA and SCL lines for a start condition and the proper address. The I<sup>2</sup>C master initiates a data transfer by establishing a start condition, defined by a high-to-low transition on SDA while SCL remains high. This indicates that an address/data stream follows. All devices on the bus respond to the start condition and acquire the next eight bits from the master (the 7-bit address plus the R/W bit) MSB first. The master sends the 7-bit device address with the read/write bit to all the slaves on the bus. The device with the matching address responds by pulling the data line (SDA) low during the ninth clock pulse. This ninth bit is known as an acknowledge bit. All other devices withdraw from the bus at this point and return to the idle condition.

The R/W bit determines the direction of the data. A Logic 0 on the LSB of the first byte means that the master is to write information to the slave, whereas a Logic 1 means that the master is to read information from the slave after writing the address and repeating the start address. A data transfer takes place until a master initiates a stop condition. A stop condition occurs when SDA transitions from low to high while SCL is held high.

Stop and start conditions can be detected at any stage during the data transfer. If these conditions are asserted out of sequence during normal read and write operations, the ADAU1977 immediately jumps to the idle condition.

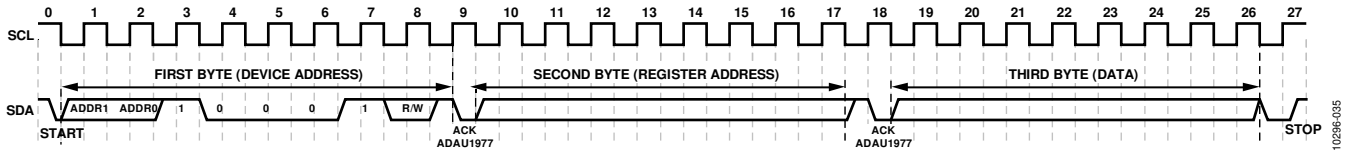

Figure 35. I<sup>2</sup>C Write to ADAU1977 Single Byte

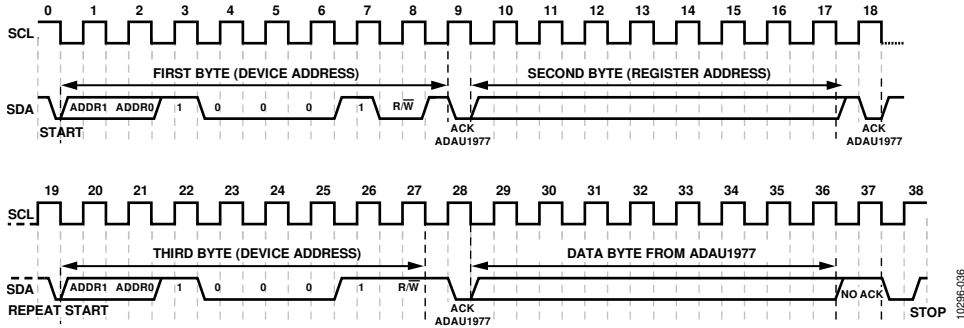

Figure 36. I<sup>2</sup>C Read from ADAU1977 Single Byte



**I<sup>2</sup>C Read and Write Operations**

Figure 37 shows the format of a single-word write operation. Every ninth clock pulse, the ADAU1977 issues an acknowledge by pulling SDA low.

Figure 38 shows the format of a burst mode write sequence. This figure shows an example of a write to sequential single-byte registers. The ADAU1977 increments its address register after every byte because the requested address corresponds to a register or memory area with a 1-byte word length.

Figure 39 shows the format of a single-word read operation. Note that the first R/W bit is 0, indicating a write operation. This is because the address still needs to be written to set up the internal address. After the ADAU1977 acknowledges the receipt of the address, the master must issue a repeated start command

followed by the chip address byte with the R/W bit set to 1 (read). This causes the ADAU1977 SDA to reverse and begin driving data back to the master. The master then responds every ninth pulse with an acknowledge pulse to the ADAU1977.

Figure 40 shows the format of a burst mode read sequence. This figure shows an example of a read from sequential single-byte registers. The ADAU1977 increments its address registers after every byte because the ADAU1977 uses an 8-bit register address.

Figure 37 to Figure 40 use the following abbreviations:

- S = start bit
- P = stop bit
- AM = acknowledge by master
- AS = acknowledge by slave

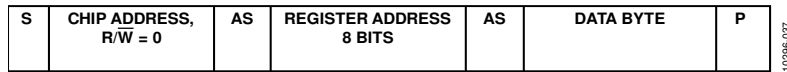

Figure 37. Single-Word I<sup>2</sup>C Write Format

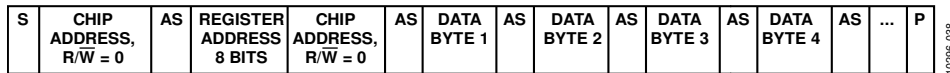

Figure 38. Burst Mode I<sup>2</sup>C Write Format

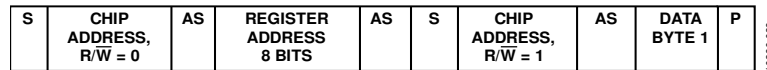

Figure 39. Single-Word I<sup>2</sup>C Read Format

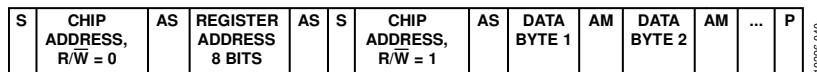

Figure 40. Burst Mode I<sup>2</sup>C Read Format

**SPI MODE**

By default, the ADAU1977 is in I<sup>2</sup>C mode. To invoke SPI control mode, pull  $\overline{\text{CLATCH}}$  low three times. This can be done by performing three dummy writes to the SPI port (the ADAU1977 does not acknowledge these three writes; see Figure 41). Beginning with the fourth SPI write, data can be written to or read from the device. The ADAU1977 can be taken out of SPI mode only by a full reset initiated by power cycling the device.

The SPI port uses a 4-wire interface, consisting of the  $\overline{\text{CLATCH}}$ , CCLK, CIN, and COUT signals, and it is always a slave port. The  $\overline{\text{CLATCH}}$  signal should go low at the beginning of a transaction and high at the end of a transaction. The CCLK signal latches CIN on a low-to-high transition. COUT data is shifted out of the ADAU1977 on the falling edge of CCLK and should be clocked into a receiving device, such as a microcontroller, on the CCLK rising edge. The CIN signal carries the serial input data, and the COUT signal carries the serial output data. The COUT signal remains tristated until a read operation is requested. This allows direct connection to other SPI-compatible peripheral COUT ports for sharing the same system controller port. All SPI transactions have the same basic format shown in Table 24. A timing diagram is shown in Figure 3. All data should be written MSB first.

**Chip Address R/W**

The LSB of the first byte of an SPI transaction is a R/W bit. This bit determines whether the communication is a read (Logic Level 1) or a write (Logic Level 0). This format is shown in Table 22.

**Table 22. ADAU1977 SPI Address and R/W Byte Format**

Bit 7	Bit 6	Bit 5	Bit 4	Bit 3	Bit 2	Bit 1	Bit 0
0	0	0	0	0	0	0	R/W

**Register Address**

The 8-bit address word is decoded to a location in one of the registers. This address is the location of the appropriate register.

**Table 24. Generic Control Word Format**

Byte 0	Byte 1	Byte 2	Byte 3 <sup>1</sup>
Device Address[6:0], R/W	Register Address[7:0]	Data[7:0]	Data[7:0]

<sup>1</sup> Continues to end of data.

**Data Bytes**

The number of data bytes varies according to the register being accessed. During a burst mode write, an initial register address is written followed by a continuous sequence of data for consecutive register locations.

A sample timing diagram for a single-word SPI write operation to a register is shown in Figure 42. A sample timing diagram of a single-word SPI read operation is shown in Figure 43. The COUT pin goes from being high-Z to being driven at the beginning of Byte 3. In this example, Byte 0 to Byte 1 contain the device address, the R/W bit, and the register address to be read. Subsequent bytes carry the data from the device.

**Standalone Mode**

The ADAU1977 can also be operated in standalone mode. However, in standalone mode, the boost converter, microphone bias, and diagnostics blocks are powered down. To set the part in standalone mode, pull the SA\_MODE pin to IOVDD. In this mode, some pins change functionality to provide more flexibility (see Table 23 for more information).

**Table 23. Pin Functionality in Standalone Mode**

Pin Function	Setting	Description
ADDR0	0	I <sup>2</sup> S SAI format
	1	TDM modes, determined by the SDATAOUT2 pin
ADDR1	0	Master mode SAI
	1	Slave mode SAI
SDA	0	MCLK = 256 × f <sub>s</sub> , PLL on
	1	MCLK = 384 × f <sub>s</sub> , PLL on
SCL	0	48 kHz sample rate
	1	96 kHz sample rate
SDATAOUT2	0	TDM4—LRCLK pulse
	1	TDM8—LRCLK pulse
FAULT	0	Slot 1 to Slot 4 in TDM8
	1	Slot 5 to Slot 8 in TDM8

If set for TDM8 mode, the FAULT pin is used as an input for assigning the ADC data slot to prevent collision with other data on TDM bus.

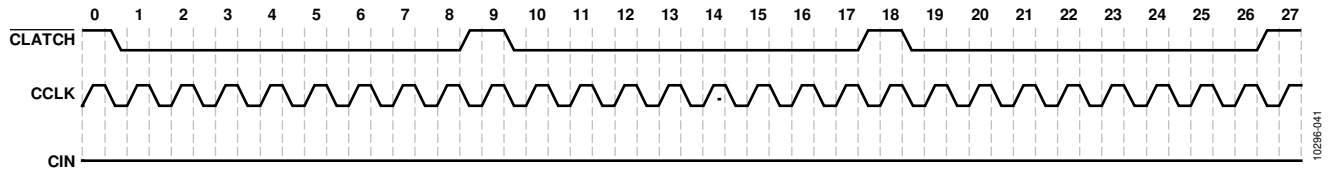

Figure 41. SPI Mode Initial Sequence

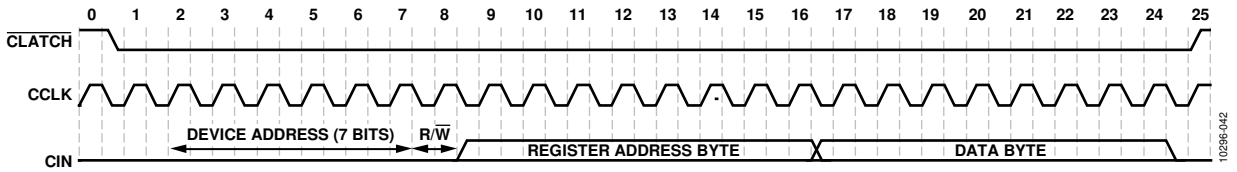

Figure 42. SPI Write to ADAU1977 Clocking (Single-Word Write Mode)

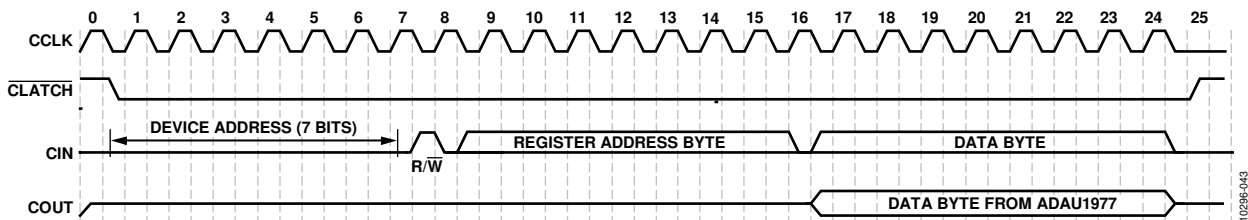

Figure 43. SPI Read from ADAU1977 Clocking (Single-Word Read Mode)

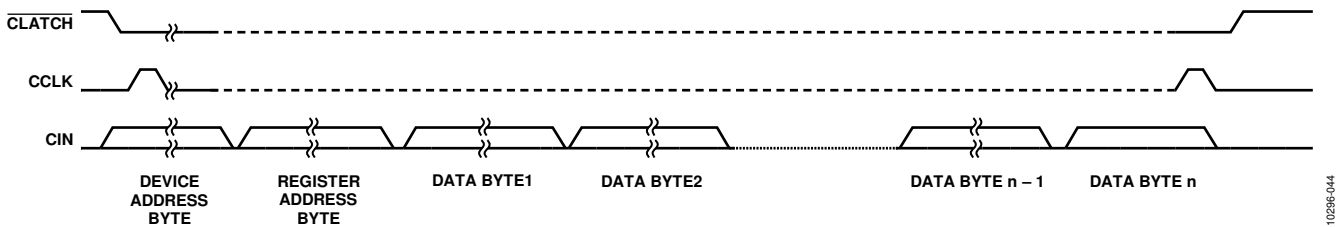

Figure 44. SPI Write to ADAU1977 (Multiple Bytes)

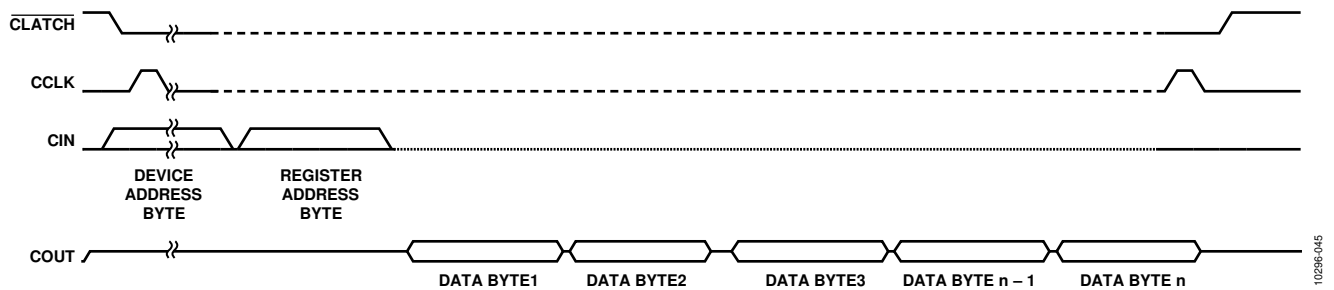

Figure 45. SPI Read from ADAU1977 (Multiple Bytes)

## REGISTER SUMMARY

Table 25 is the control register summary. The registers can be accessed using the I<sup>2</sup>C control port or the SPI control port.

Table 25. ADAU1977 Register Summary

Reg	Name	Bits	Bit 7	Bit 6	Bit 5	Bit 4	Bit 3	Bit 2	Bit 1	Bit 0	Reset	RW
0x00	M_POWER	[7:0]	S_RST	RESERVED						PWUP	0x00	RW
0x01	PLL_CONTROL	[7:0]	PLL_LOCK	PLL_MUTE	RESERVED	CLK_S	RESERVED	MCS			0x41	RW
0x02	BST_CONTROL	[7:0]	BST_GOOD	FS_RATE		BOOST_SW_FREQ	OV_EN	BOOST_OV	OC_EN	BOOST_OC	0x4A	RW
0x03	MB_BST_CONTROL	[7:0]	MB_VOLTS			MB_EN	BOOST_EN	MRCV	BOOST_RCVR	0x7D	RW	
0x04	BLOCK_POWER_SAI	[7:0]	LR_POL	BCLKEDGE	LDO_EN	VREF_EN	ADC_EN4	ADC_EN3	ADC_EN2	ADC_EN1	0x3F	RW
0x05	SAI_CTRL0	[7:0]	SDATA_FMT		SAI		FS			0x02	RW	
0x06	SAI_CTRL1	[7:0]	SDATA_SEL	SLOT_WIDTH		DATA_WIDTH	LR_MODE	SAI_MSB	BCLKRATE	SAI_MS	0x00	RW
0x07	SAI_CMAP12	[7:0]	CMAP_C2			CMAP_C1			0x10	RW		
0x08	SAI_CMAP34	[7:0]	CMAP_C4			CMAP_C3			0x32	RW		
0x09	SAI_OVERTEMP	[7:0]	SAI_DRV_C4	SAI_DRV_C3	SAI_DRV_C2	SAI_DRV_C1	DRV_HIZ	OT_MCRV	OT_RCVR	OT	0xF0	RW
0x0A	POSTADC_GAIN1	[7:0]	PADC_GAIN1						0xA0	RW		
0x0B	POSTADC_GAIN2	[7:0]	PADC_GAIN2						0xA0	RW		
0x0C	POSTADC_GAIN3	[7:0]	PADC_GAIN3						0xA0	RW		
0x0D	POSTADC_GAIN4	[7:0]	PADC_GAIN4						0xA0	RW		
0x0E	MISC_CONTROL	[7:0]	SUM_MODE		RESERVED	MMUTE	RESERVED			DC_CAL	0x02	RW
0x10	DIAG_CONTROL	[7:0]	RESERVED				DIAG_EN4	DIAG_EN3	DIAG_EN2	DIAG_EN1	0x0F	RW
0x11	DIAG_STATUS1	[7:0]	RESERVED	MIC_SHORT1	MICH_OPEN1	MICH_SB1	MICH_SG1	MICH_SMB1	MICL_SB1	MICL_SG1	0x00	RW
0x12	DIAG_STATUS2	[7:0]	RESERVED	MIC_SHORT2	MICH_OPEN2	MICH_SB2	MICH_SG2	MICH_SMB2	MICL_SB2	MICL_SG2	0x00	RW
0x13	DIAG_STATUS3	[7:0]	RESERVED	MIC_SHORT3	MICH_OPEN3	MICH_SB3	MICH_SG3	MICH_SMB3	MICL_SB3	MICL_SG3	0x00	RW
0x14	DIAG_STATUS4	[7:0]	RESERVED	MIC_SHORT4	MICH_OPEN4	MICH_SB4	MICH_SG4	MICH_SMB4	MICL_SB4	MICL_SG4	0x00	RW
0x15	DIAG_IRQ1	[7:0]	RESERVED	IRQ_RESET	IRQ_DRIVE	IRQ_POL	DIAG_MASK4	DIAG_MASK3	DIAG_MASK2	DIAG_MASK1	0x20	RW
0x16	DIAG_IRQ2	[7:0]	BST_FAULT_MASK	MIC_SHORT_MASK	MICH_OPEN_MASK	MICH_SB_MASK	MICH_SG_MASK	RESERVED	MICL_SB_MASK	MICL_SG_MASK	0x00	RW
0x17	DIAG_ADJUST1	[7:0]	SHT_T_TRIP		SHT_M_TRIP		SHT_G_TRIP		SHT_B_TRIP		0x00	RW
0x18	DIAG_ADJUST2	[7:0]	RESERVED		FAULT_TO		RESERVED	HYST_SM_EN	HYST_SG_EN	HYST_SB_EN	0x20	RW
0x19	ASDC_CLIP	[7:0]	RESERVED				ADC_CLIP4	ADC_CLIP3	ADC_CLIP2	ADC_CLIP1	0x00	RW
0x1A	DC_HPF_CAL	[7:0]	DC_SUB_C4	DC_SUB_C3	DC_SUB_C2	DC_SUB_C1	DC_HPF_C4	DC_HPF_C3	DC_HPF_C2	DC_HPF_C1	0x00	RW

## REGISTER DETAILS

### MASTER POWER AND SOFT RESET REGISTER

Address: 0x00, Reset: 0x00, Name: M\_POWER

The power management control register is used for enabling boost regulator, microphone bias, PLL, band gap reference, ADC, and LDO regulator.

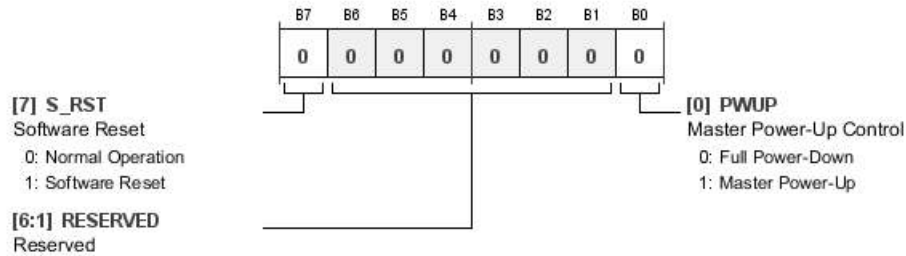
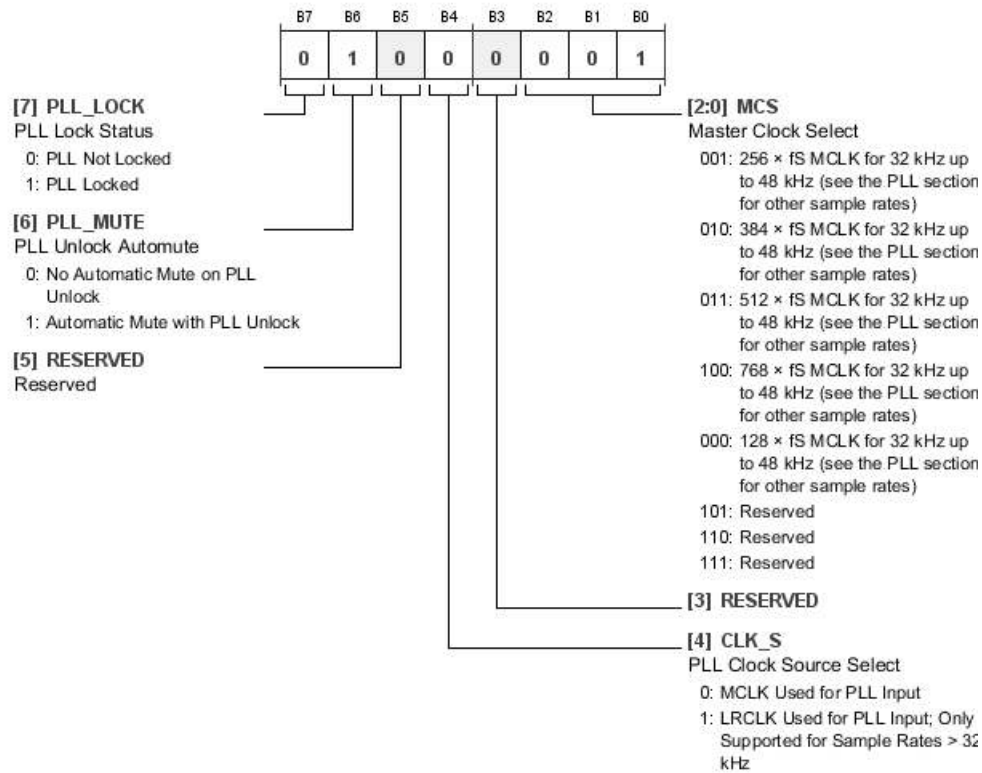

Table 26. Bit Descriptions for M\_POWER

Bits	Bit Name	Settings	Description	Reset	Access
7	S_RST	0 1	Software Reset. The software reset resets all internal circuitry and places all control registers to their default state. It is not necessary to reset the <a href="#">ADAU1977</a> during a power-up or power-down cycle. Normal Operation Software Reset	0x0	RW
[6:1]	RESERVED		Reserved.	0x00	RW
0	PWUP	0 1	Master Power-Up Control. The master power-up control fully powers up or powers down the <a href="#">ADAU1977</a> . This must be set to 1 to power up the <a href="#">ADAU1977</a> . Individual blocks can be powered down via their respective power control registers. Full Power-Down Master Power-Up	0x0	RW

**PLL CONTROL REGISTER**

Address: 0x01, Reset: 0x41, Name: PLL\_CONTROL



**Table 27. Bit Descriptions for PLL\_CONTROL**

Bits	Bit Name	Settings	Description	Reset	Access
7	PLL_LOCK	0 1	PLL Lock Status. PLL lock status bit. When one PLL is locked. PLL Not Locked PLL Locked	0x0	R
6	PLL_MUTE	0 1	PLL Unlock Automute. When set to 1, mutes the ADC output if PLL becomes unlocked. No Automatic Mute on PLL Unlock Automatic Mute with PLL Unlock	0x1	RW
5	RESERVED		Reserved.	0x0	RW
4	CLK_S	0 1	PLL Clock Source Select. Selecting input clock source for PLL. MCLK Used for PLL Input LRCLK Used for PLL Input; Only Supported for Sample Rates > 32 kHz	0x0	RW
[2:0]	MCS	001 010 011 100 000	Master Clock Select. MCS bits determine the frequency multiplication ratio of the PLL. It must be set based on the input MCLK frequency and sample rate. 256 × f <sub>S</sub> MCLK for 32 kHz up to 48 kHz (see the PLL section for other sample rates) 384 × f <sub>S</sub> MCLK for 32 kHz up to 48 kHz (see the PLL section for other sample rates) 512 × f <sub>S</sub> MCLK for 32 kHz up to 48 kHz (see the PLL section for other sample rates) 768 × f <sub>S</sub> MCLK for 32 kHz up to 48 kHz (see the PLL section for other sample rates) 128 × f <sub>S</sub> MCLK for 32 kHz up to 48 kHz (see the PLL section for other sample rates)	0x1	RW

Bits	Bit Name	Settings	Description	Reset	Access
		101	Reserved		
		110	Reserved		
		111	Reserved		

**DC-TO-DC BOOST CONVERTER CONTROL REGISTER**

Address: 0x02, Reset: 0x4A, Name: BST\_CONTROL

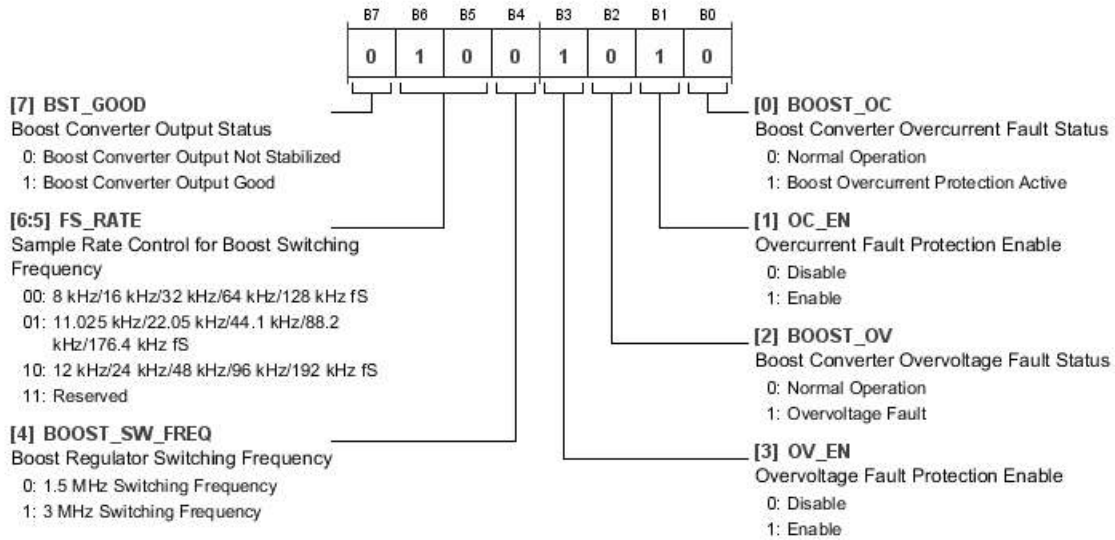
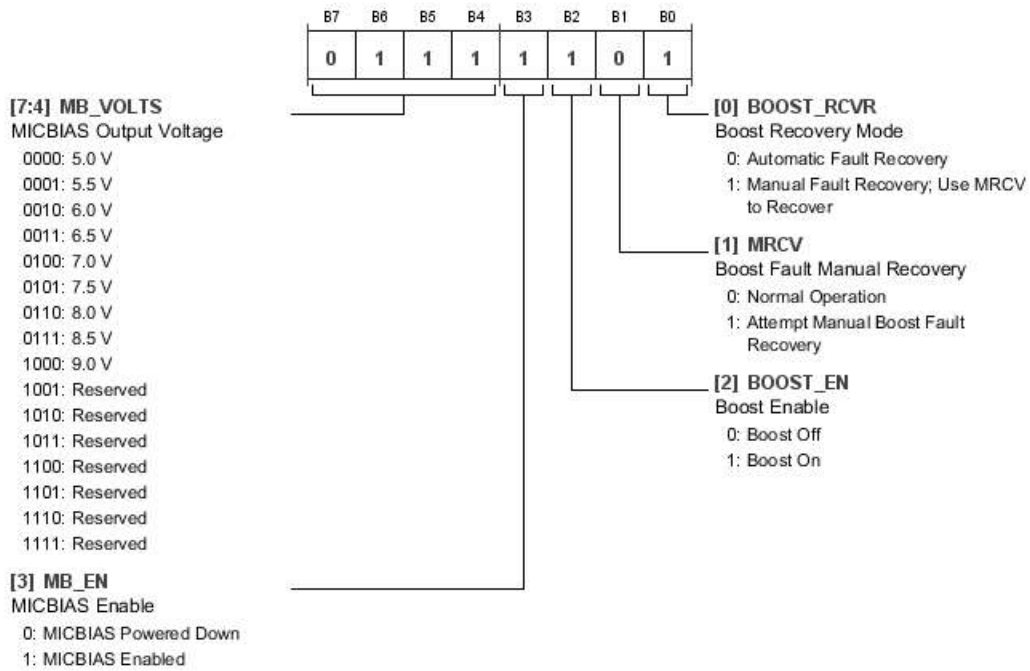

Table 28. Bit Descriptions for BST\_CONTROL

Bits	Bit Name	Settings	Description	Reset	Access
7	BST_GOOD	0 1	Boost Converter Output Status. Boost Converter Output Not Stabilized Boost Converter Output Good	0x0	R
[6:5]	FS_RATE	00 01 10 11	Sample Rate Control for Boost Switching Frequency. 8 kHz/16 kHz/32 kHz/64 kHz/128 kHz f <sub>s</sub> 11.025 kHz/22.05 kHz/44.1 kHz/88.2 kHz/176.4 kHz f <sub>s</sub> 12 kHz/24 kHz/48 kHz/96 kHz/192 kHz f <sub>s</sub> Reserved	0x2	RW
4	BOOST_SW_FREQ	0 1	Boost Regulator Switching Frequency. 1.5 MHz Switching Frequency 3 MHz Switching Frequency	0x0	RW
3	OV_EN	0 1	Overvoltage Fault Protection Enable. Disable Enable	0x1	RW
2	BOOST_OV	0 1	Boost Converter Overvoltage Fault Status. Normal Operation Overvoltage Fault	0x0	R
1	OC_EN	0 1	Overcurrent Fault Protection Enable. Disable Enable	0x1	RW
0	BOOST_OC	0 1	Boost Converter Overcurrent Fault Status. Normal Operation Boost Overcurrent Protection Active	0x0	R

**MICBIAS AND BOOST CONTROL REGISTER**

Address: 0x03, Reset: 0x7D, Name: MB\_BST\_CONTROL



**Table 29. Bit Descriptions for MB\_BST\_CONTROL**

Bits	Bit Name	Settings	Description	Reset	Access
[7:4]	MB_VOLTS	0000 0001 0010 0011 0100 0101 0110 0111 1000 1001 1010 1011 1100 1101 1110 1111	MICBIAS Output Voltage. 5.0 V 5.5 V 6.0 V 6.5 V 7.0 V 7.5 V 8.0 V 8.5 V 9.0 V Reserved Reserved Reserved Reserved Reserved Reserved	0x7	RW
3	MB_EN	0 1	MICBIAS Enable. MICBIAS Powered Down MICBIAS Enabled	0x1	RW
2	BOOST_EN	0 1	Boost Enable. Boost Off Boost On	0x1	RW
1	MRCV	0 1	Boost Fault Manual Recovery. Normal Operation Attempt Manual Boost Fault Recovery	0x0	W



Bits	Bit Name	Settings	Description	Reset	Access
0	BOOST_RCVR	0 1	Boost Recovery Mode. Automatic Fault Recovery Manual Fault Recovery; Use MRCV to Recover	0x1	RW

## BLOCK POWER CONTROL AND SERIAL PORT CONTROL REGISTER

Address: 0x04, Reset: 0x3F, Name: BLOCK\_POWER\_SAI

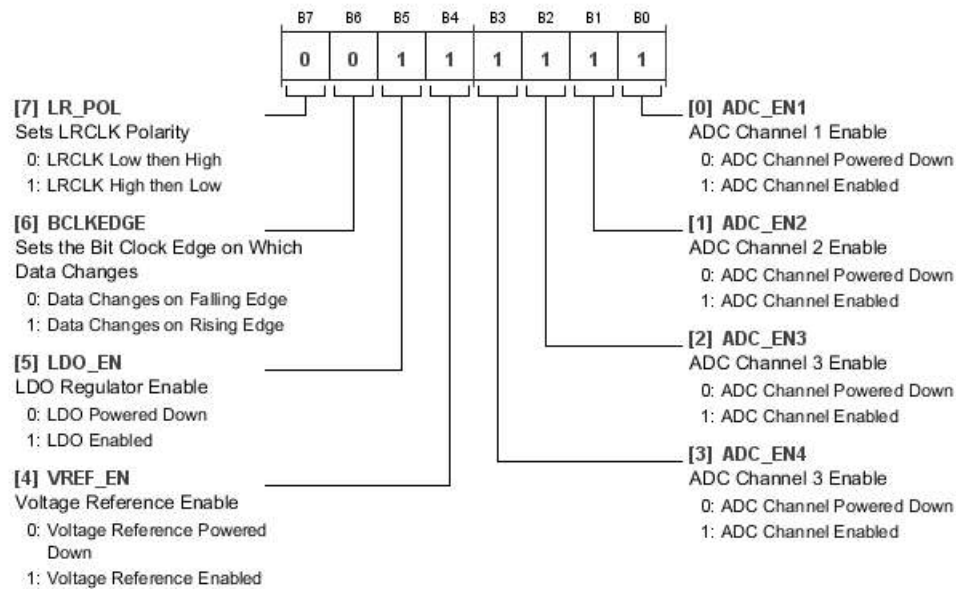
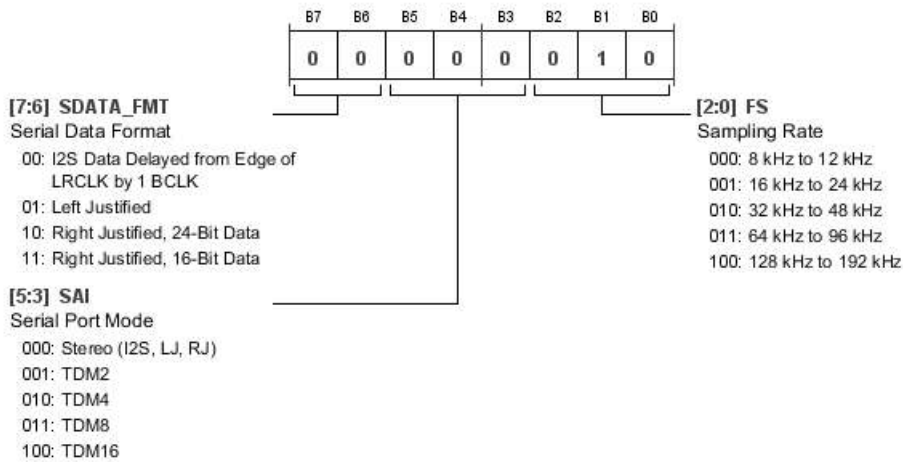

Table 30. Bit Descriptions for BLOCK\_POWER\_SAI

Bits	Bit Name	Settings	Description	Reset	Access
7	LR_POL	0 1	Sets LRCLK Polarity. LRCLK Low then High LRCLK High then Low	0x0	RW
6	BCLKEDGE	0 1	Sets the Bit Clock Edge on Which Data Changes. Data Changes on Falling Edge Data Changes on Rising Edge	0x0	RW
5	LDO_EN	0 1	LDO Regulator Enable. LDO Powered Down LDO Enabled	0x1	RW
4	VREF_EN	0 1	Voltage Reference Enable. Voltage Reference Powered Down Voltage Reference Enabled	0x1	RW
3	ADC_EN4	0 1	ADC Channel 3 Enable. ADC Channel Powered Down ADC Channel Enabled	0x1	RW
2	ADC_EN3	0 1	ADC Channel 3 Enable. ADC Channel Powered Down ADC Channel Enabled	0x1	RW
1	ADC_EN2	0 1	ADC Channel 2 Enable. ADC Channel Powered Down ADC Channel Enabled	0x1	RW
0	ADC_EN1	0 1	ADC Channel 1 Enable. ADC Channel Powered Down ADC Channel Enabled	0x1	RW

**SERIAL PORT CONTROL REGISTER1**

Address: 0x05, Reset: 0x02, Name: SAI\_CTRL0



**Table 31. Bit Descriptions for SAI\_CTRL0**

Bits	Bit Name	Settings	Description	Reset	Access
[7:6]	SDATA_FMT	00 01 10 11	Serial Data Format. I <sup>2</sup> S Data Delayed from Edge of LRCLK by 1 BCLK Left Justified Right Justified, 24-Bit Data Right Justified, 16-Bit Data	0x0	RW
[5:3]	SAI	000 001 010 011 100	Serial Port Mode. Stereo (I <sup>2</sup> S, LJ, RJ) TDM2 TDM4 TDM8 TDM16	0x0	RW
[2:0]	FS	000 001 010 011 100	Sampling Rate. 8 kHz to 12 kHz 16 kHz to 24 kHz 32 kHz to 48 kHz 64 kHz to 96 kHz 128 kHz to 192 kHz	0x2	RW

**SERIAL PORT CONTROL REGISTER2**

Address: 0x06, Reset: 0x00, Name: SAI\_CTRL1

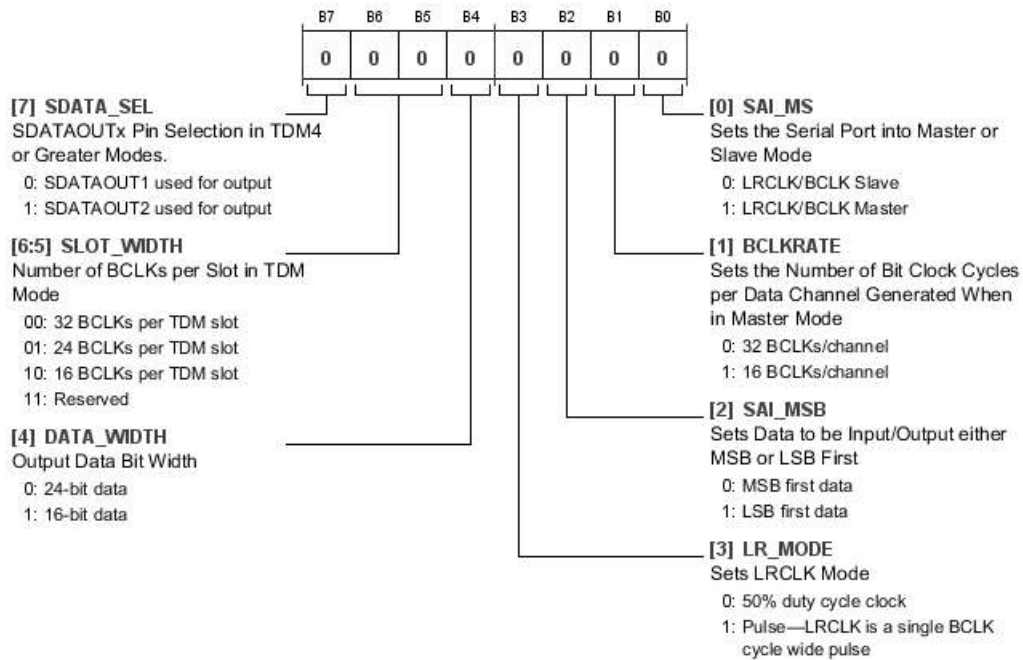
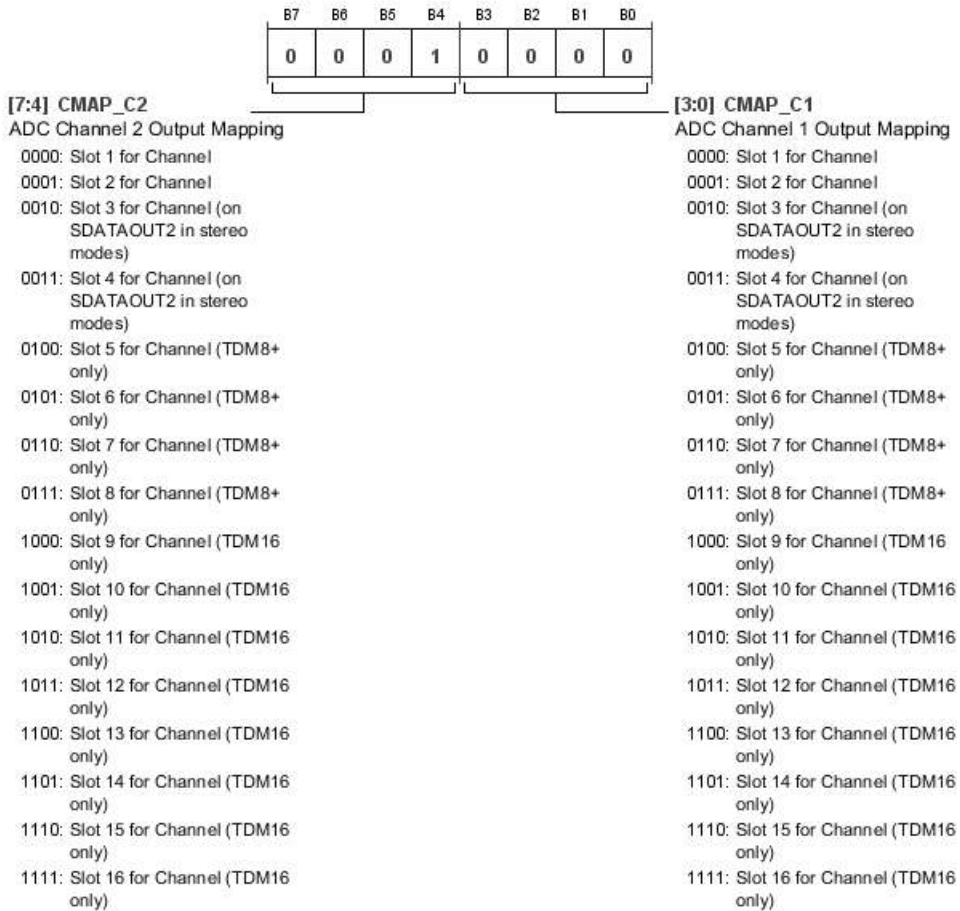

Table 32. Bit Descriptions for SAI\_CTRL1

Bits	Bit Name	Settings	Description	Reset	Access
7	SDATA_SEL	0 1	SDATAOUTx Pin Selection in TDM4 or Greater Modes. SDATAOUT1 used for output SDATAOUT2 used for output	0x0	RW
[6:5]	SLOT_WIDTH	00 01 10 11	Number of BCLKs per Slot in TDM Mode. 32 BCLKs per TDM slot 24 BCLKs per TDM slot 16 BCLKs per TDM slot Reserved	0x0	RW
4	DATA_WIDTH	0 1	Output Data Bit Width. 24-bit data 16-bit data	0x0	RW
3	LR_MODE	0 1	Sets LRCLK Mode. 50% duty cycle clock Pulse—LRCLK is a single BCLK cycle wide pulse	0x0	RW
2	SAI_MSB	0 1	Sets Data to be Input/Output either MSB or LSB First. MSB first data LSB first data	0x0	RW
1	BCLKRATE	0 1	Sets the Number of Bit Clock Cycles per Data Channel Generated When in Master Mode. 32 BCLKs/channel 16 BCLKs/channel	0x0	RW
0	SAI_MS	0 1	Sets the Serial Port into Master or Slave Mode. LRCLK/BCLK Slave LRCLK/BCLK Master	0x0	RW

**CHANNEL MAPPING FOR OUTPUT SERIAL PORTS REGISTER**

Address: 0x07, Reset: 0x10, Name: SAI\_CMAP12



**Table 33. Bit Descriptions for SAI\_CMAP12**

Bits	Bit Name	Settings	Description	Reset	Access
[7:4]	CMAP_C2		ADC Channel 2 Output Mapping.	0x1	RW
		0000	Slot 1 for Channel		
		0001	Slot 2 for Channel		
		0010	Slot 3 for Channel (on SDATAOUT2 in stereo modes)		
		0011	Slot 4 for Channel (on SDATAOUT2 in stereo modes)		
		0100	Slot 5 for Channel (TDM8+ only)		
		0101	Slot 6 for Channel (TDM8+ only)		
		0110	Slot 7 for Channel (TDM8+ only)		
		0111	Slot 8 for Channel (TDM8+ only)		
		1000	Slot 9 for Channel (TDM16 only)		
		1001	Slot 10 for Channel (TDM16 only)		
		1010	Slot 11 for Channel (TDM16 only)		
		1011	Slot 12 for Channel (TDM16 only)		
		1100	Slot 13 for Channel (TDM16 only)		
		1101	Slot 14 for Channel (TDM16 only)		
		1110	Slot 15 for Channel (TDM16 only)		
		1111	Slot 16 for Channel (TDM16 only)		

Bits	Bit Name	Settings	Description	Reset	Access
[3:0]	CMAP_C1		ADC Channel 1 Output Mapping. If CMAP is set to a slot that doesn't exist for a given serial mode, then that channel will not be driven. For example, if CMAP is set to Slot 9 and the serial format is I2S, then that channel will not be driven. If more than one channel is set to the same slot, only the lowest channel number will be driven; other channels will not be driven.	0x0	RW
		0000	Slot 1 for Channel		
		0001	Slot 2 for Channel		
		0010	Slot 3 for Channel (on SDATAOUT2 in stereo modes)		
		0011	Slot 4 for Channel (on SDATAOUT2 in stereo modes)		
		0100	Slot 5 for Channel (TDM8+ only)		
		0101	Slot 6 for Channel (TDM8+ only)		
		0110	Slot 7 for Channel (TDM8+ only)		
		0111	Slot 8 for Channel (TDM8+ only)		
		1000	Slot 9 for Channel (TDM16 only)		
		1001	Slot 10 for Channel (TDM16 only)		
		1010	Slot 11 for Channel (TDM16 only)		
		1011	Slot 12 for Channel (TDM16 only)		
		1100	Slot 13 for Channel (TDM16 only)		
		1101	Slot 14 for Channel (TDM16 only)		
		1110	Slot 15 for Channel (TDM16 only)		
		1111	Slot 16 for Channel (TDM16 only)		

**CHANNEL MAPPING FOR OUTPUT SERIAL PORTS REGISTER**

Address: 0x08, Reset: 0x32, Name: SAI\_CMAP34

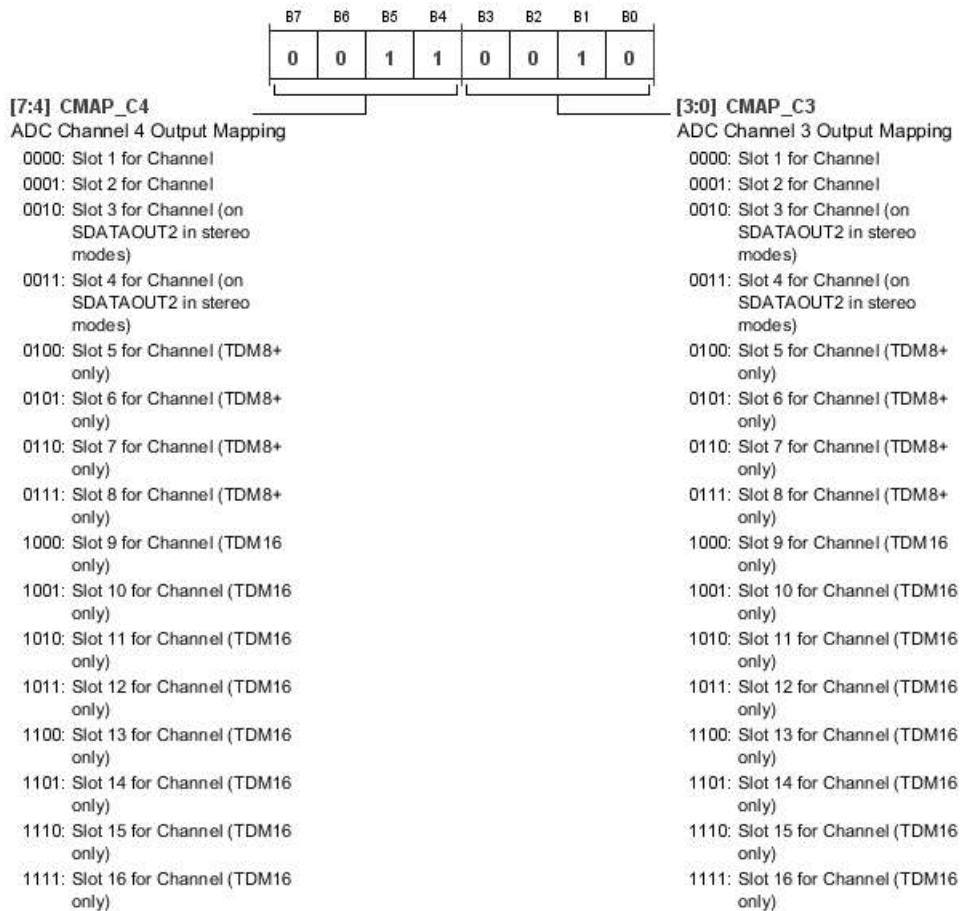

**Table 34. Bit Descriptions for SAI\_CMAP34**

Bits	Bit Name	Settings	Description	Reset	Access
[7:4]	CMAP_C4		ADC Channel 4 Output Mapping.	0x3	RW
		0000	Slot 1 for Channel		
		0001	Slot 2 for Channel		
		0010	Slot 3 for Channel (on SDATAOUT2 in stereo modes)		
		0011	Slot 4 for Channel (on SDATAOUT2 in stereo modes)		
		0100	Slot 5 for Channel (TDM8+ only)		
		0101	Slot 6 for Channel (TDM8+ only)		
		0110	Slot 7 for Channel (TDM8+ only)		
		0111	Slot 8 for Channel (TDM8+ only)		
		1000	Slot 9 for Channel (TDM16 only)		
		1001	Slot 10 for Channel (TDM16 only)		
		1010	Slot 11 for Channel (TDM16 only)		
		1011	Slot 12 for Channel (TDM16 only)		
		1100	Slot 13 for Channel (TDM16 only)		
		1101	Slot 14 for Channel (TDM16 only)		
		1110	Slot 15 for Channel (TDM16 only)		
		1111	Slot 16 for Channel (TDM16 only)		

Bits	Bit Name	Settings	Description	Reset	Access
[3:0]	CMAP_C3		ADC Channel 3 Output Mapping.	0x2	RW
		0000	Slot 1 for Channel		
		0001	Slot 2 for Channel		
		0010	Slot 3 for Channel (on SDATAOUT2 in stereo modes)		
		0011	Slot 4 for Channel (on SDATAOUT2 in stereo modes)		
		0100	Slot 5 for Channel (TDM8+ only)		
		0101	Slot 6 for Channel (TDM8+ only)		
		0110	Slot 7 for Channel (TDM8+ only)		
		0111	Slot 8 for Channel (TDM8+ only)		
		1000	Slot 9 for Channel (TDM16 only)		
		1001	Slot 10 for Channel (TDM16 only)		
		1010	Slot 11 for Channel (TDM16 only)		
		1011	Slot 12 for Channel (TDM16 only)		
		1100	Slot 13 for Channel (TDM16 only)		
		1101	Slot 14 for Channel (TDM16 only)		
		1110	Slot 15 for Channel (TDM16 only)		
		1111	Slot 16 for Channel (TDM16 only)		

**SERIAL OUTPUT DRIVE AND OVERTEMPERATURE PROTECTION CONTROL REGISTER**

Address: 0x09, Reset: 0xF0, Name: SAI\_OVERTEMP

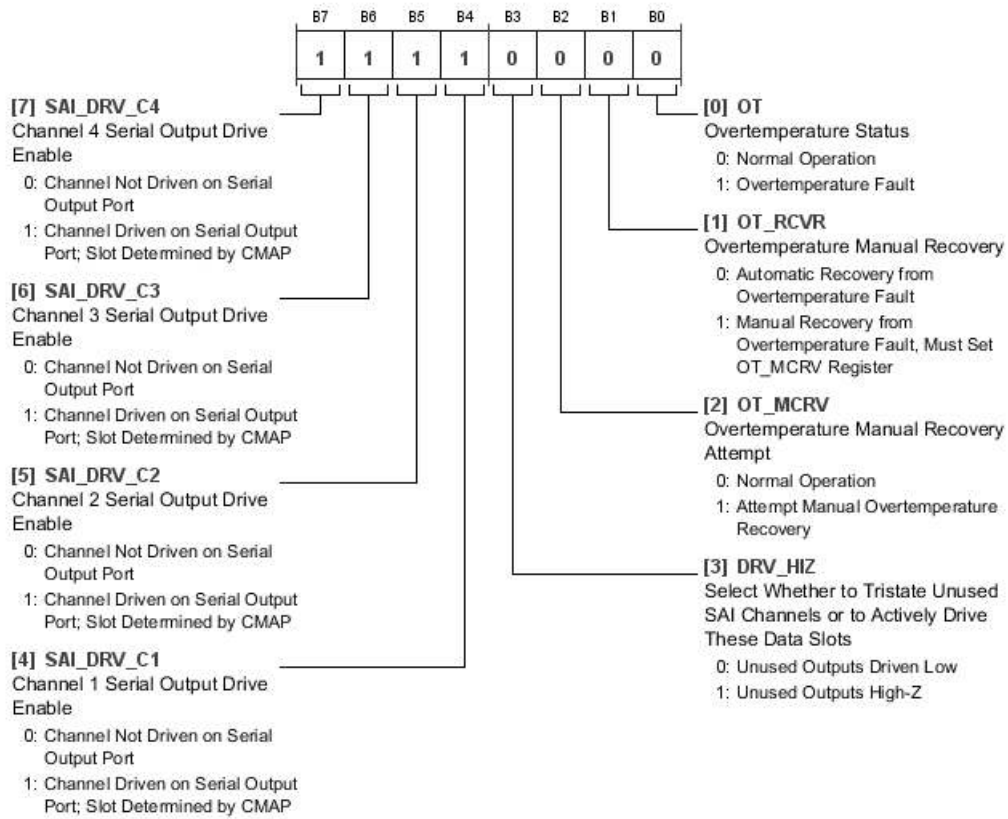

Table 35. Bit Descriptions for SAI\_OVERTEMP

Bits	Bit Name	Settings	Description	Reset	Access
7	SAI_DRV_C4	0 1	Channel 4 Serial Output Drive Enable. Channel Not Driven on Serial Output Port Channel Driven on Serial Output Port; Slot Determined by CMAP	0x1	RW
6	SAI_DRV_C3	0 1	Channel 3 Serial Output Drive Enable. Channel Not Driven on Serial Output Port Channel Driven on Serial Output Port; Slot Determined by CMAP	0x1	RW
5	SAI_DRV_C2	0 1	Channel 2 Serial Output Drive Enable. Channel Not Driven on Serial Output Port Channel Driven on Serial Output Port; Slot Determined by CMAP	0x1	RW
4	SAI_DRV_C1	0 1	Channel 1 Serial Output Drive Enable. Channel Not Driven on Serial Output Port Channel Driven on Serial Output Port; Slot Determined by CMAP	0x1	RW
3	DRV_HIZ	0 1	Select Whether to Tristate Unused SAI Channels or to Actively Drive These Data Slots. Unused Outputs Driven Low Unused Outputs High-Z	0x0	RW
2	OT_MCRV	0 1	Overtemperature Manual Recovery Attempt. Normal Operation Attempt Manual Overtemperature Recovery	0x0	W
1	OT_RCVR	0 1	Overtemperature Manual Recovery. Automatic Recovery from Overtemperature Fault Manual Recovery from Overtemperature Fault, Must Set OT_MCRV Register	0x0	RW



Bits	Bit Name	Settings	Description	Reset	Access
0	OT	0 1	Overtemperature Status. Normal Operation Overtemperature Fault	0x0	R

**POST ADC GAIN CHANNEL 1 CONTROL REGISTER**

Address: 0xA0, Reset: 0xA0, Name: POSTADC\_GAIN1

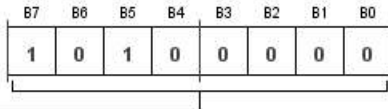

**[7:0] PADC\_GAIN1**  
 Channel 1 Post ADC Gain  
 00000000: +60 dB Gain  
 00000001: +59.625 dB Gain  
 00000010: +59.25 dB Gain  
 ... ..  
 10011111: +0.375 dB Gain  
 10100000: 0 dB Gain  
 10100001: -0.375 dB Gain  
 ... ..  
 11111110: -35.625 dB Gain  
 11111111: Mute

**Table 36. Bit Descriptions for POSTADC\_GAIN1**

Bits	Bit Name	Settings	Description	Reset	Access
[7:0]	PADC_GAIN1	00000000 00000001 00000010 ... .. 10011111 10100000 10100001 ... .. 11111110 11111111	Channel 1 Post ADC Gain. +60 dB Gain +59.625 dB Gain +59.25 dB Gain ... .. +0.375 dB Gain 0 dB Gain -0.375 dB Gain ... .. -35.625 dB Gain Mute	0xA0	RW

**POST ADC GAIN CHANNEL 2 CONTROL REGISTER**

Address: 0x0B, Reset: 0xA0, Name: POSTADC\_GAIN2

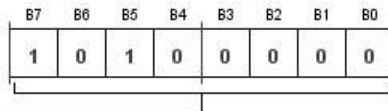

[7:0] PADG\_GAIN2  
 Channel 2 Post ADC Gain  
 00000000: +60 dB Gain  
 00000001: +59.625 dB Gain  
 00000010: +59.25 dB Gain  
 ....  
 10011111: +0.375 dB Gain  
 10100000: 0 dB Gain  
 10100001: -0.375 dB Gain  
 ....  
 11111110: -35.625 dB Gain  
 11111111: Mute

**Table 37. Bit Descriptions for POSTADC\_GAIN2**

Bits	Bit Name	Settings	Description	Reset	Access
[7:0]	PADG_GAIN2	00000000	+60 dB Gain	0xA0	RW
		00000001	+59.625 dB Gain		
		00000010	+59.25 dB Gain		
		...	...		
		10011111	+0.375 dB Gain		
		10100000	0 dB Gain		
		10100001	-0.375 dB Gain		
		...	...		
		11111110	-35.625 dB Gain		
		11111111	Mute		

**POST ADC GAIN CHANNEL 3 CONTROL REGISTER**

Address: 0x0C, Reset: 0xA0, Name: POSTADC\_GAIN3

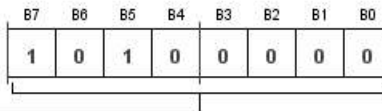

[7:0] PADC\_GAIN3  
 Channel 3 Post ADC Gain  
 00000000: +60 dB Gain  
 00000001: +59.625 dB Gain  
 00000010: +59.25 dB Gain  
 ....  
 10011111: +0.375 dB Gain  
 10100000: 0 dB Gain  
 10100001: -0.375 dB Gain  
 ....  
 11111110: -35.625 dB Gain  
 11111111: Mute

**Table 38. Bit Descriptions for POSTADC\_GAIN3**

Bits	Bit Name	Settings	Description	Reset	Access
[7:0]	PADC_GAIN3		Channel 3 Post ADC Gain.	0xA0	RW
		00000000	+60 dB Gain		
		00000001	+59.625 dB Gain		
		00000010	+59.25 dB Gain		
		...	...		
		10011111	+0.375 dB Gain		
		10100000	0 dB Gain		
		10100001	-0.375 dB Gain		
		...	...		
		11111110	-35.625 dB Gain		
		11111111	Mute		

**POST ADC GAIN CHANNEL 4 CONTROL REGISTER**

Address: 0x0D, Reset: 0xA0, Name: POSTADC\_GAIN4

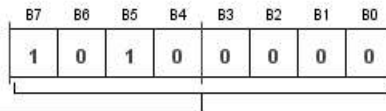

[7:0] PADC\_GAIN4  
 Channel 4 Post ADC Gain  
 00000000: +60 dB Gain  
 00000001: +59.625 dB Gain  
 00000010: +59.25 dB Gain  
 ....  
 10011111: +0.375 dB Gain  
 10100000: 0 dB Gain  
 10100001: -0.375 dB Gain  
 ....  
 11111110: -35.625 dB Gain  
 11111111: Mute

**Table 39. Bit Descriptions for POSTADC\_GAIN4**

Bits	Bit Name	Settings	Description	Reset	Access
[7:0]	PADC_GAIN4		Channel 4 Post ADC Gain.	0xA0	RW
		00000000	+60 dB Gain		
		00000001	+59.625 dB Gain		
		00000010	+59.25 dB Gain		
		...	...		
		10011111	+0.375 dB Gain		
		10100000	0 dB Gain		
		10100001	-0.375 dB Gain		
		...	...		
		11111110	-35.625 dB Gain		
		11111111	Mute		

**HIGH-PASS FILTER AND DC OFFSET CONTROL REGISTER AND MASTER MUTE**

Address: 0x0E, Reset: 0x02, Name: MISC\_CONTROL

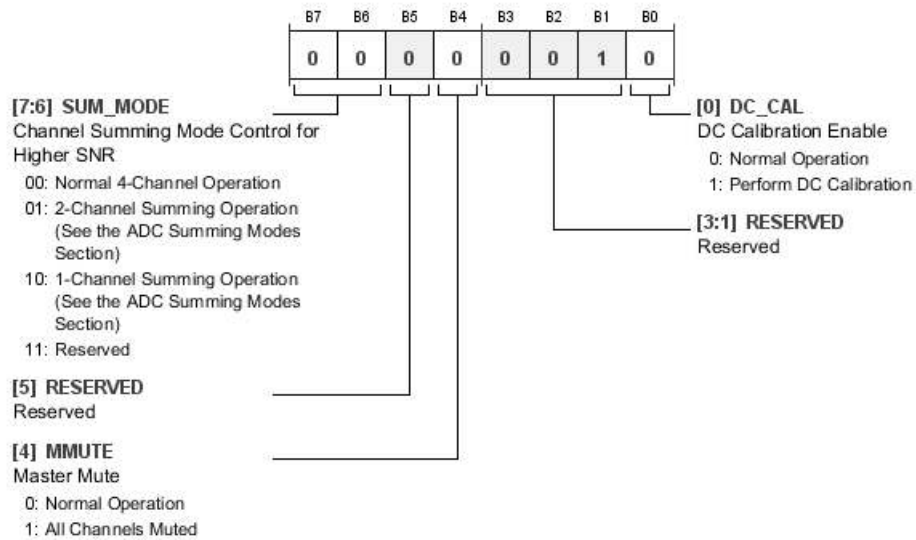

**Table 40. Bit Descriptions for MISC\_CONTROL**

Bits	Bit Name	Settings	Description	Reset	Access
[7:6]	SUM_MODE	00 01 10 11	Channel Summing Mode Control for Higher SNR. Normal 4-Channel Operation 2-Channel Summing Operation (See the ADC Summing Modes Section) 1-Channel Summing Operation (See the ADC Summing Modes Section) Reserved	0x0	RW
5	RESERVED		Reserved.	0x0	RW
4	MMUTE	0 1	Master Mute. Normal Operation All Channels Muted	0x0	RW
[3:1]	RESERVED		Reserved.	0x1	RW
0	DC_CAL	0 1	DC Calibration Enable. Normal Operation Perform DC Calibration	0x0	RW

**DIAGNOSTICS CONTROL REGISTER**

Address: 0x10, Reset: 0x0F, Name: DIAG\_CONTROL

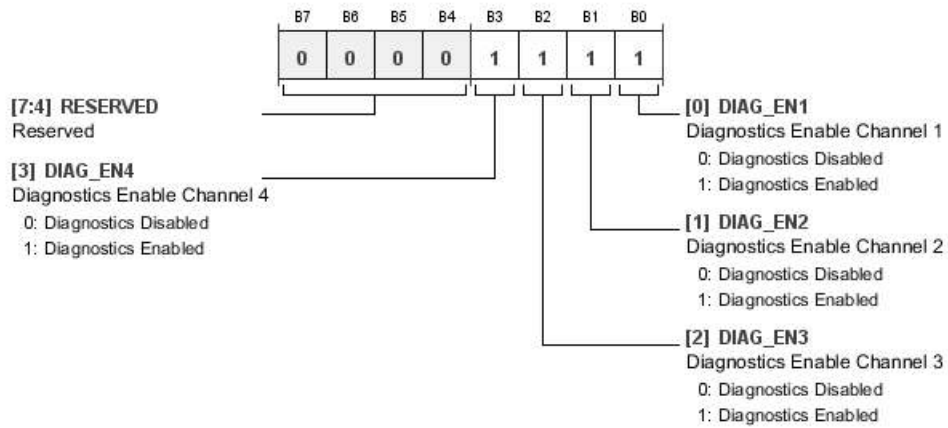
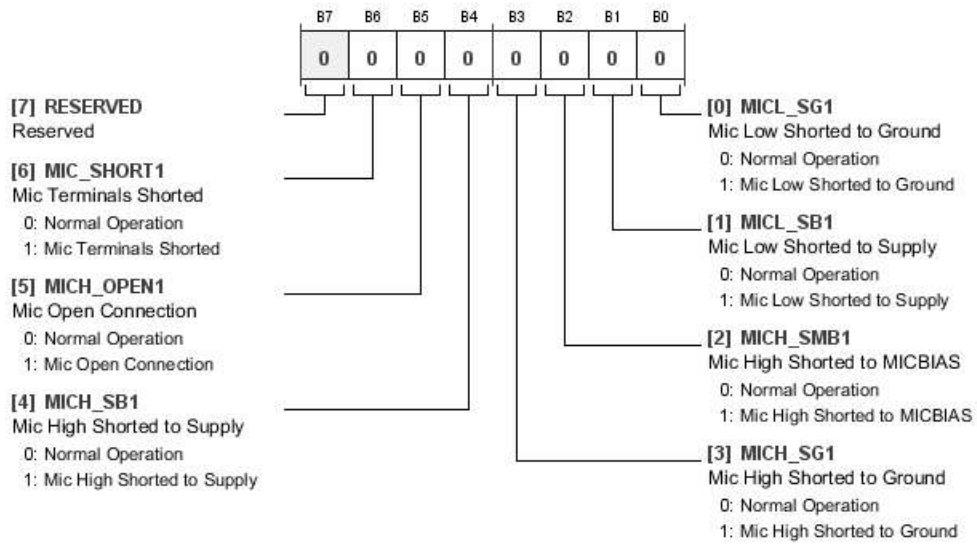

Table 41. Bit Descriptions for DIAG\_CONTROL

Bits	Bit Name	Settings	Description	Reset	Access
[7:4]	RESERVED		Reserved.	0x0	RW
3	DIAG_EN4	0 1	Diagnostics Enable Channel 4. 0: Diagnostics Disabled 1: Diagnostics Enabled	0x1	RW
2	DIAG_EN3	0 1	Diagnostics Enable Channel 3. 0: Diagnostics Disabled 1: Diagnostics Enabled	0x1	RW
1	DIAG_EN2	0 1	Diagnostics Enable Channel 2. 0: Diagnostics Disabled 1: Diagnostics Enabled	0x1	RW
0	DIAG_EN1	0 1	Diagnostics Enable Channel 1. 0: Diagnostics Disabled 1: Diagnostics Enabled	0x1	RW

**DIAGNOSTICS REPORT REGISTER CHANNEL 1**

Address: 0x11, Reset: 0x00, Name: DIAG\_STATUS1

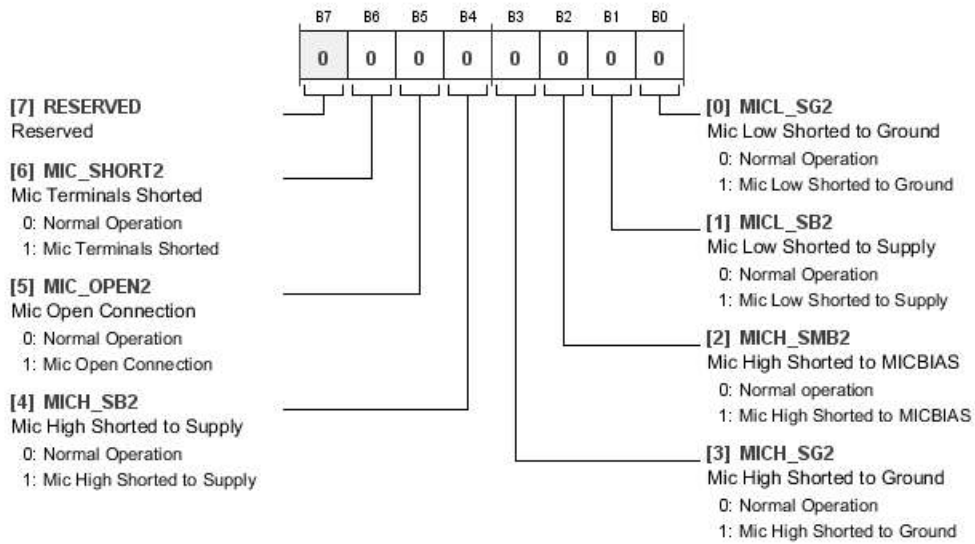

**Table 42. Bit Descriptions for DIAG\_STATUS1**

Bits	Bit Name	Settings	Description	Reset	Access
7	RESERVED		Reserved.	0x0	RW
6	MIC_SHORT1	0 1	Mic Terminals Shorted. Normal Operation Mic Terminals Shorted	0x0	R
5	MICH_OPEN1	0 1	Mic Open Connection. Normal Operation Mic Open Connection	0x0	R
4	MICH_SB1	0 1	Mic High Shorted to Supply. Normal Operation Mic High Shorted to Supply	0x0	R
3	MICH_SG1	0 1	Mic High Shorted to Ground. Normal Operation Mic High Shorted to Ground	0x0	R
2	MICH_SMB1	0 1	Mic High Shorted to MICBIAS. Normal Operation Mic High Shorted to MICBIAS	0x0	R
1	MICL_SB1	0 1	Mic Low Shorted to Supply. Normal Operation Mic Low Shorted to Supply	0x0	R
0	MICL_SG1	0 1	Mic Low Shorted to Ground. Normal Operation Mic Low Shorted to Ground	0x0	R

**DIAGNOSTICS REPORT REGISTER CHANNEL 2**

Address: 0x12, Reset: 0x00, Name: DIAG\_STATUS2



**Table 43. Bit Descriptions for DIAG\_STATUS2**

Bits	Bit Name	Settings	Description	Reset	Access
7	RESERVED		Reserved.	0x0	RW
6	MIC_SHORT2	0 1	Mic Terminals Shorted. Normal Operation Mic Terminals Shorted	0x0	R
5	MIC_OPEN2	0 1	Mic Open Connection. Normal Operation Mic Open Connection	0x0	R
4	MICH_SB2	0 1	Mic High Shorted to Supply. Normal Operation Mic High Shorted to Supply	0x0	R
3	MICH_SG2	0 1	Mic High Shorted to Ground. Normal Operation Mic High Shorted to Ground	0x0	R
2	MICH_SMB2	0 1	Mic High Shorted to MICBIAS. Normal operation Mic High Shorted to MICBIAS	0x0	R
1	MICL_SB2	0 1	Mic Low Shorted to Supply. Normal Operation Mic Low Shorted to Supply	0x0	R
0	MICL_SG2	0 1	Mic Low Shorted to Ground. Normal Operation Mic Low Shorted to Ground	0x0	R



**DIAGNOSTICS REPORT REGISTER CHANNEL 3**

Address: 0x13, Reset: 0x00, Name: DIAG\_STATUS3

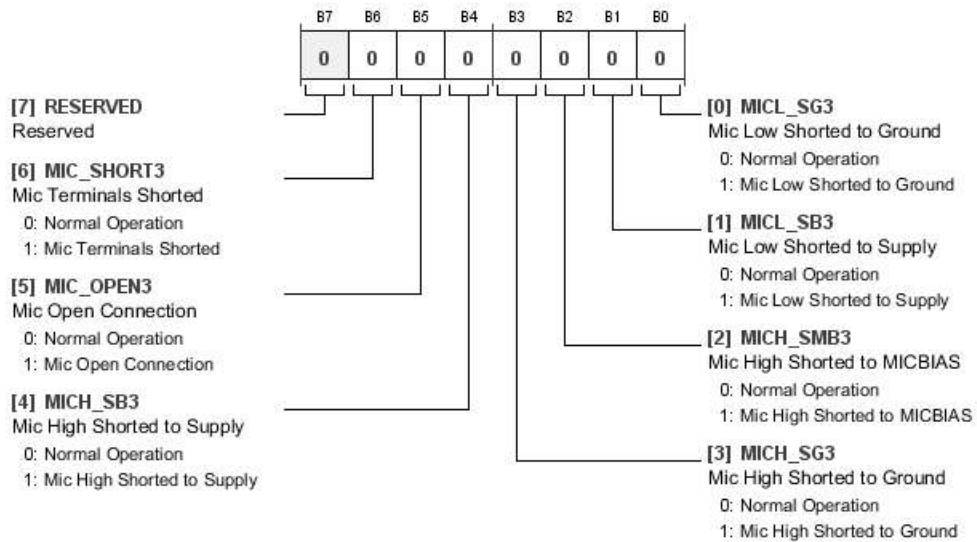
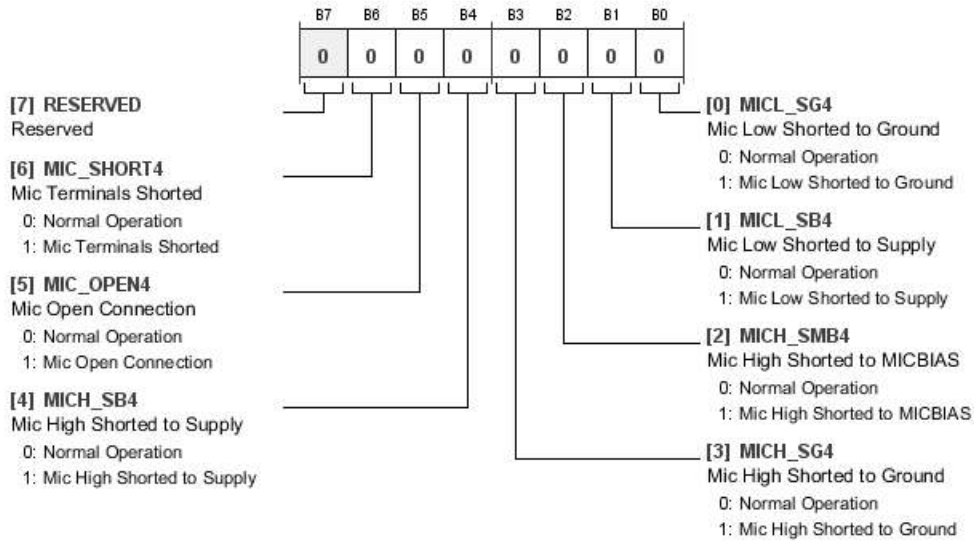

**Table 44. Bit Descriptions for DIAG\_STATUS3**

Bits	Bit Name	Settings	Description	Reset	Access
7	RESERVED		Reserved.	0x0	RW
6	MIC_SHORT3	0 1	Mic Terminals Shorted. Normal Operation Mic Terminals Shorted	0x0	R
5	MIC_OPEN3	0 1	Mic Open Connection. Normal Operation Mic Open Connection	0x0	R
4	MICH_SB3	0 1	Mic High Shorted to Supply. Normal Operation Mic High Shorted to Supply	0x0	R
3	MICH_SG3	0 1	Mic High Shorted to Ground. Normal Operation Mic High Shorted to Ground	0x0	R
2	MICH_SMB3	0 1	Mic High Shorted to MICBIAS. Normal Operation Mic High Shorted to MICBIAS	0x0	R
1	MICL_SB3	0 1	Mic Low Shorted to Supply. Normal Operation Mic Low Shorted to Supply	0x0	R
0	MICL_SG3	0 1	Mic Low Shorted to Ground. Normal Operation Mic Low Shorted to Ground	0x0	R

**DIAGNOSTICS REPORT REGISTER CHANNEL 4**

Address: 0x14, Reset: 0x00, Name: DIAG\_STATUS4

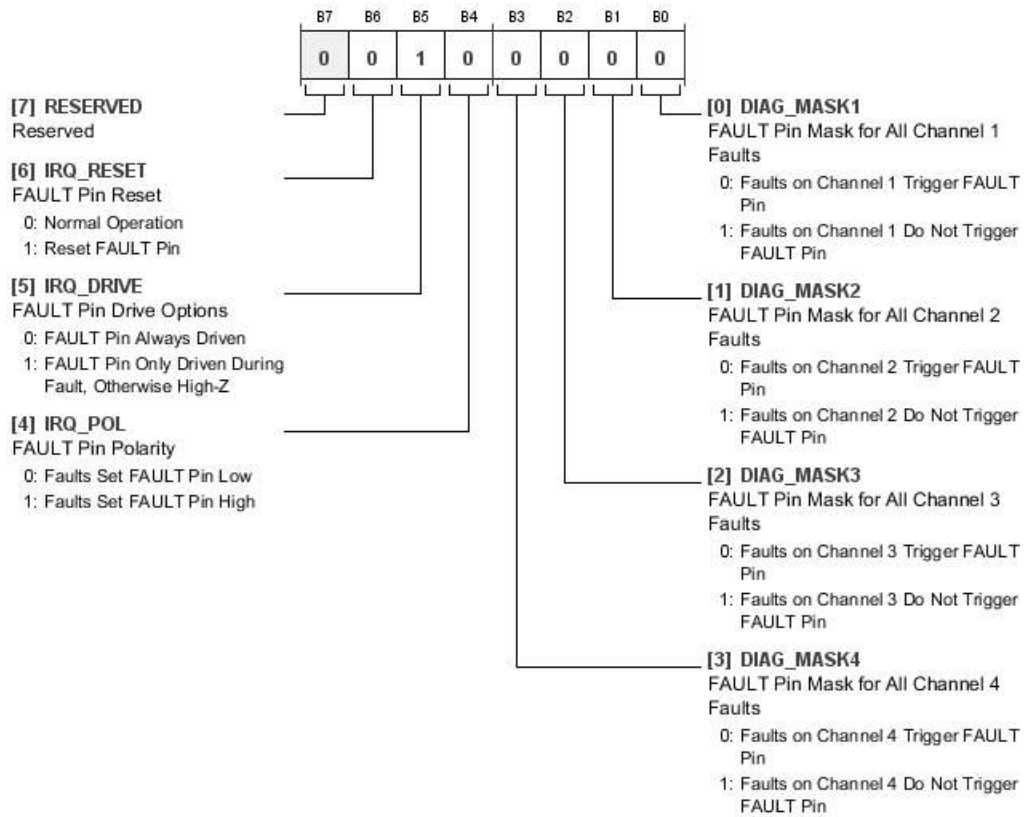

**Table 45. Bit Descriptions for DIAG\_STATUS4**

Bits	Bit Name	Settings	Description	Reset	Access
7	RESERVED		Reserved.	0x0	RW
6	MIC_SHORT4	0 1	Mic Terminals Shorted. Normal Operation Mic Terminals Shorted	0x0	R
5	MIC_OPEN4	0 1	Mic Open Connection. Normal Operation Mic Open Connection	0x0	R
4	MICH_SB4	0 1	Mic High Shorted to Supply. Normal Operation Mic High Shorted to Supply	0x0	R
3	MICH_SG4	0 1	Mic High Shorted to Ground. Normal Operation Mic High Shorted to Ground	0x0	R
2	MICH_SMB4	0 1	Mic High Shorted to MICBIAS. Normal Operation Mic High Shorted to MICBIAS	0x0	R
1	MICL_SB4	0 1	Mic Low Shorted to Supply. Normal Operation Mic Low Shorted to Supply	0x0	R
0	MICL_SG4	0 1	Mic Low Shorted to Ground. Normal Operation Mic Low Shorted to Ground	0x0	R

**DIAGNOSTICS INTERRUPT PIN CONTROL REGISTER 1**

Address: 0x15, Reset: 0x20, Name: DIAG\_IRQ1



**Table 46. Bit Descriptions for DIAG\_IRQ1**

Bits	Bit Name	Settings	Description	Reset	Access
7	RESERVED		Reserved.	0x0	RW
6	IRQ_RESET	0 1	FAULT Pin Reset. Normal Operation Reset FAULT Pin	0x0	RW
5	IRQ_DRIVE	0 1	FAULT Pin Drive Options. FAULT Pin Always Driven FAULT Pin Only Driven During Fault, Otherwise High-Z	0x1	RW
4	IRQ_POL	0 1	FAULT Pin Polarity. Faults Set FAULT Pin Low Faults Set FAULT Pin High	0x0	RW
3	DIAG_MASK4	0 1	FAULT Pin Mask for All Channel 4 Faults. Faults on Channel 4 Trigger FAULT Pin Faults on Channel 4 Do Not Trigger FAULT Pin	0x0	RW
2	DIAG_MASK3	0 1	FAULT Pin Mask for All Channel 3 Faults. Faults on Channel 3 Trigger FAULT Pin Faults on Channel 3 Do Not Trigger FAULT Pin	0x0	RW
1	DIAG_MASK2	0 1	FAULT Pin Mask for All Channel 2 Faults. Faults on Channel 2 Trigger FAULT Pin Faults on Channel 2 Do Not Trigger FAULT Pin	0x0	RW
0	DIAG_MASK1	0 1	FAULT Pin Mask for All Channel 1 Faults. Faults on Channel 1 Trigger FAULT Pin Faults on Channel 1 Do Not Trigger FAULT Pin	0x0	RW

**DIAGNOSTICS INTERRUPT PIN CONTROL REGISTER 2**

Address: 0x16, Reset: 0x00, Name: DIAG\_IRQ2

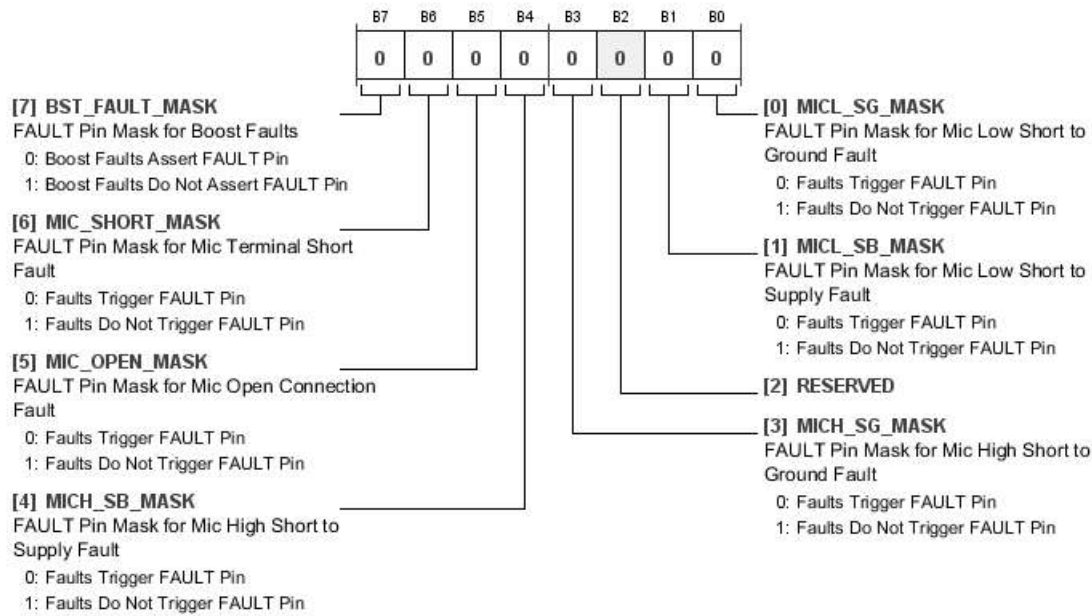
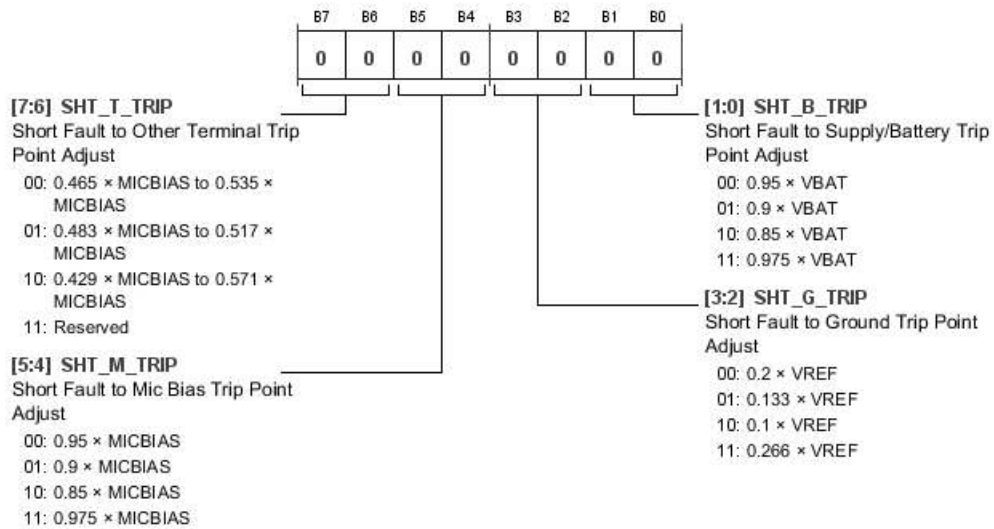

Table 47. Bit Descriptions for DIAG\_IRQ2

Bits	Bit Name	Settings	Description	Reset	Access
7	BST_FAULT_MASK	0 1	FAULT Pin Mask for Boost Faults. Boost Faults Assert FAULT Pin Boost Faults Do Not Assert FAULT Pin	0x0	RW
6	MIC_SHORT_MASK	0 1	FAULT Pin Mask for Mic Terminal Short Fault. Faults Trigger FAULT Pin Faults Do Not Trigger FAULT Pin	0x0	RW
5	MIC_OPEN_MASK	0 1	FAULT Pin Mask for Mic Open Connection Fault. Faults Trigger FAULT Pin Faults Do Not Trigger FAULT Pin	0x0	RW
4	MICH_SB_MASK	0 1	FAULT Pin Mask for Mic High Short to Supply Fault. Faults Trigger FAULT Pin Faults Do Not Trigger FAULT Pin	0x0	RW
3	MICH_SG_MASK	0 1	FAULT Pin Mask for Mic High Short to Ground Fault. Faults Trigger FAULT Pin Faults Do Not Trigger FAULT Pin	0x0	RW
1	MICL_SB_MASK	0 1	FAULT Pin Mask for Mic Low Short to Supply Fault. Faults Trigger FAULT Pin Faults Do Not Trigger FAULT Pin	0x0	RW
0	MICL_SG_MASK	0 1	FAULT Pin Mask for Mic Low Short to Ground Fault. Faults Trigger FAULT Pin Faults Do Not Trigger FAULT Pin	0x0	RW

**DIAGNOSTICS ADJUSTMENTS REGISTER 1**

Address: 0x17, Reset: 0x00, Name: DIAG\_ADJUST1

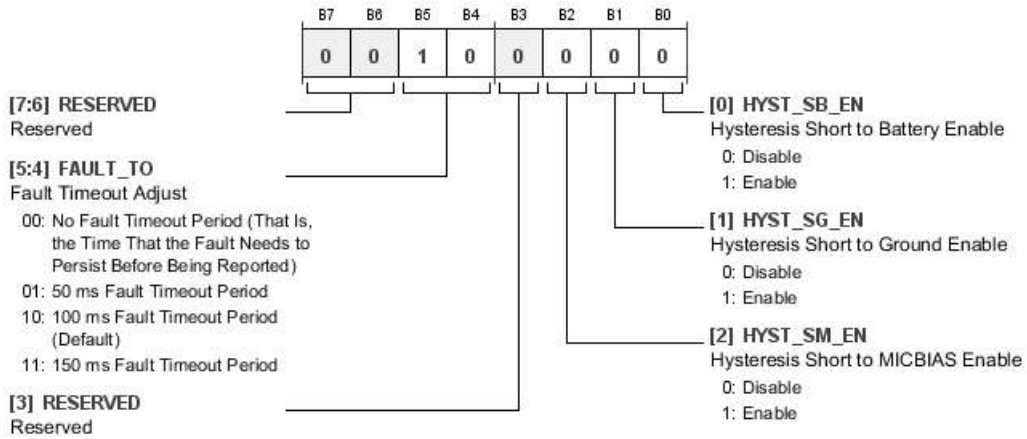

**Table 48. Bit Descriptions for DIAG\_ADJUST1**

Bits	Bit Name	Settings	Description	Reset	Access
[7:6]	SHT_T_TRIP	00 01 10 11	Short Fault to Other Terminal Trip Point Adjust. $0.465 \times \text{MICBIAS}$ to $0.535 \times \text{MICBIAS}$ $0.483 \times \text{MICBIAS}$ to $0.517 \times \text{MICBIAS}$ $0.429 \times \text{MICBIAS}$ to $0.571 \times \text{MICBIAS}$ Reserved	0x0	RW
[5:4]	SHT_M_TRIP	00 01 10 11	Short Fault to Mic Bias Trip Point Adjust. $0.95 \times \text{MICBIAS}$ $0.9 \times \text{MICBIAS}$ $0.85 \times \text{MICBIAS}$ $0.975 \times \text{MICBIAS}$	0x0	RW
[3:2]	SHT_G_TRIP	00 01 10 11	Short Fault to Ground Trip Point Adjust. $0.2 \times \text{VREF}$ $0.133 \times \text{VREF}$ $0.1 \times \text{VREF}$ $0.266 \times \text{VREF}$	0x0	RW
[1:0]	SHT_B_TRIP	00 01 10 11	Short Fault to Supply/Battery Trip Point Adjust. $0.95 \times \text{VBAT}$ $0.9 \times \text{VBAT}$ $0.85 \times \text{VBAT}$ $0.975 \times \text{VBAT}$	0x0	RW

**DIAGNOSTICS ADJUSTMENTS REGISTER 2**

Address: 0x18, Reset: 0x20, Name: DIAG\_ADJUST2



**Table 49. Bit Descriptions for DIAG\_ADJUST2**

Bits	Bit Name	Settings	Description	Reset	Access
[7:6]	RESERVED		Reserved.	0x0	RW
[5:4]	FAULT_TO	00 01 10 11	Fault Timeout Adjust. No Fault Timeout Period (That Is, the Time That the Fault Needs to Persist Before Being Reported) 50 ms Fault Timeout Period 100 ms Fault Timeout Period (Default) 150 ms Fault Timeout Period	0x2	RW
3	RESERVED		Reserved.	0x0	RW
2	HYST_SM_EN	0 1	Hysteresis Short to MICBIAS Enable. Disable Enable	0x0	RW
1	HYST_SG_EN	0 1	Hysteresis Short to Ground Enable. Disable Enable	0x0	RW
0	HYST_SB_EN	0 1	Hysteresis Short to Battery Enable. Disable Enable	0x0	RW

**ADC CLIPPING STATUS REGISTER**

Address: 0x19, Reset: 0x00, Name: ASDC\_CLIP

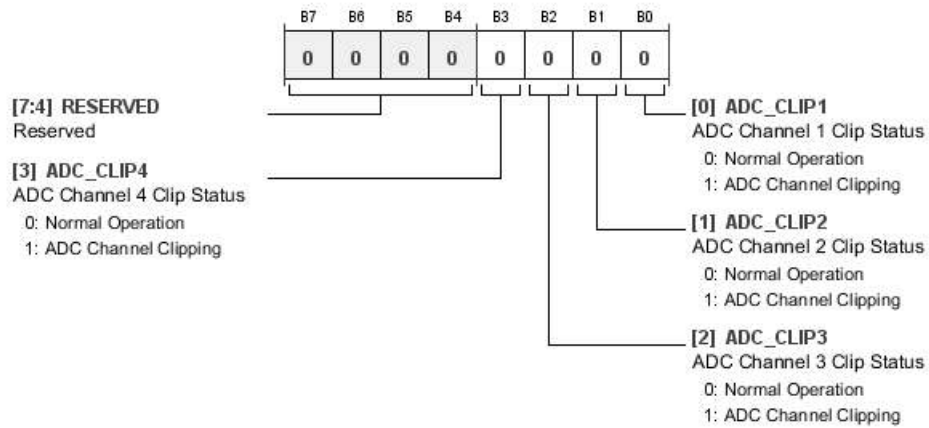
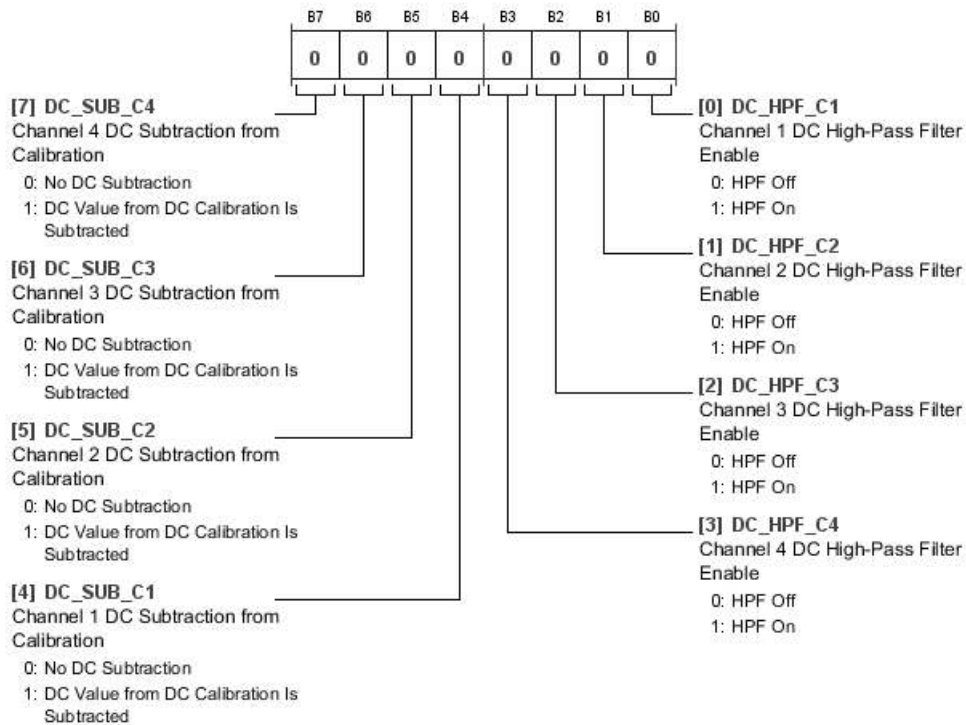

Table 50. Bit Descriptions for ASDC\_CLIP

Bits	Bit Name	Settings	Description	Reset	Access
[7:4]	RESERVED		Reserved.	0x0	RW
3	ADC_CLIP4	0 1	ADC Channel 4 Clip Status. Normal Operation ADC Channel Clipping	0x0	R
2	ADC_CLIP3	0 1	ADC Channel 3 Clip Status. Normal Operation ADC Channel Clipping	0x0	R
1	ADC_CLIP2	0 1	ADC Channel 2 Clip Status. Normal Operation ADC Channel Clipping	0x0	R
0	ADC_CLIP1	0 1	ADC Channel 1 Clip Status. Normal Operation ADC Channel Clipping	0x0	R

**DIGITAL DC HIGH-PASS FILTER AND CALIBRATION REGISTER**

Address: 0x1A, Reset: 0x00, Name: DC\_HPF\_CAL

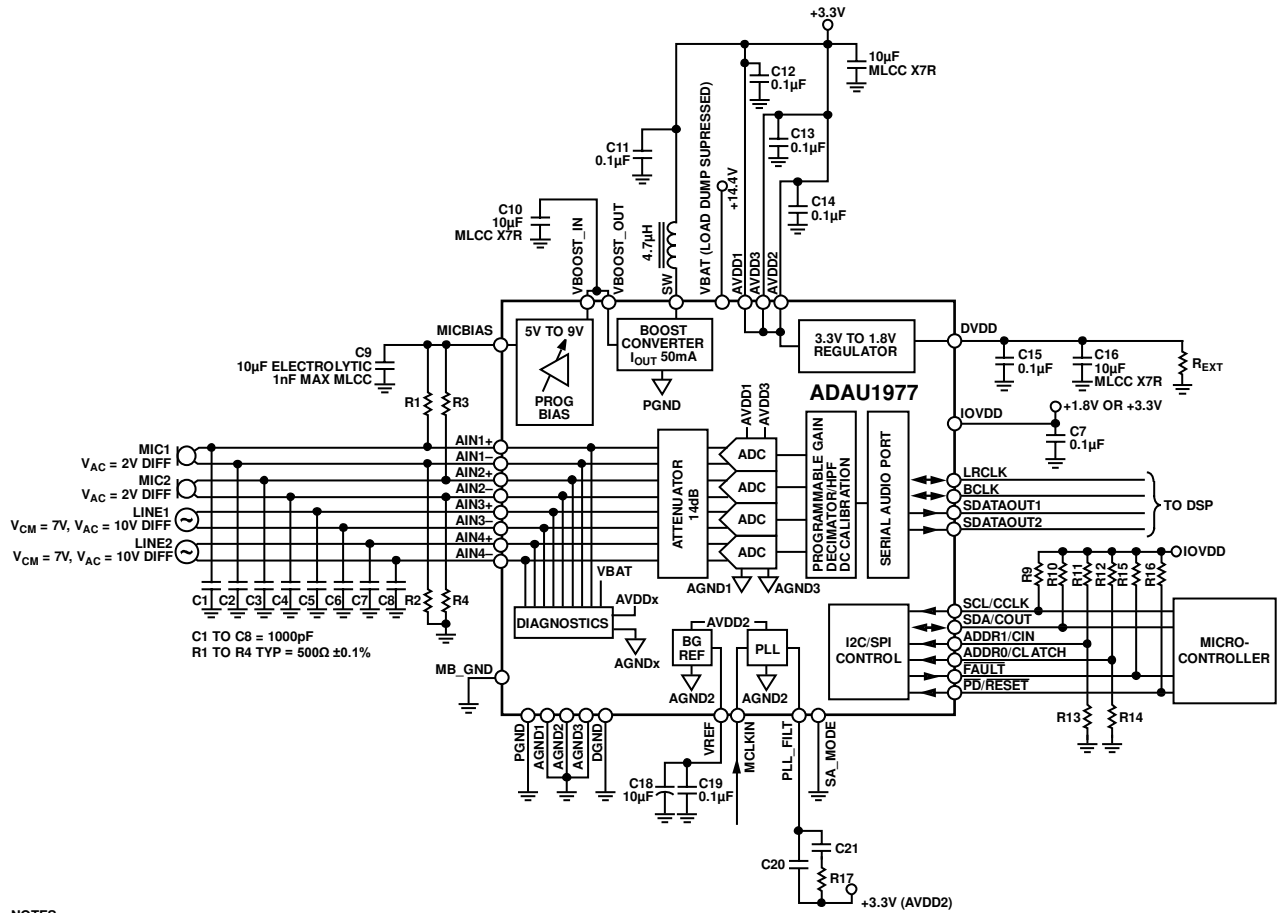

**Table 51. Bit Descriptions for DC\_HPF\_CAL**

Bits	Bit Name	Settings	Description	Reset	Access
7	DC_SUB_C4	0 1	Channel 4 DC Subtraction from Calibration. No DC Subtraction DC Value from DC Calibration Is Subtracted	0x0	RW
6	DC_SUB_C3	0 1	Channel 3 DC Subtraction from Calibration. No DC Subtraction DC Value from DC Calibration Is Subtracted	0x0	RW
5	DC_SUB_C2	0 1	Channel 2 DC Subtraction from Calibration. No DC Subtraction DC Value from DC Calibration Is Subtracted	0x0	RW
4	DC_SUB_C1	0 1	Channel 1 DC Subtraction from Calibration. No DC Subtraction DC Value from DC Calibration Is Subtracted	0x0	RW
3	DC_HPF_C4	0 1	Channel 4 DC High-Pass Filter Enable. HPF Off HPF On	0x0	RW
2	DC_HPF_C3	0 1	Channel 3 DC High-Pass Filter Enable. HPF Off HPF On	0x0	RW
1	DC_HPF_C2	0 1	Channel 2 DC High-Pass Filter Enable. HPF Off HPF On	0x0	RW
0	DC_HPF_C1	0 1	Channel 1 DC High-Pass Filter Enable. HPF Off HPF On	0x0	RW



APPLICATIONS CIRCUIT



NOTES

1. R9, R10 = TYPICAL 2kΩ.
2. R11 THROUGH R14 USED FOR SETTING THE DEVICE IN I<sup>2</sup>C MODE.
3. R15, R16 = TYPICAL 47kΩ.
4. PLL LOOP FILTER:

	PLL INPUT OPTION	
	LRCLK	MCLK
R17	4.87kΩ	1kΩ
C20	2200pF	390pF
C21	39nF	5600pF

5. FOR MORE INFORMATION ABOUT CALCULATING THE VALUE OF R<sub>EXT</sub>, SEE THE POWER-ON RESET SEQUENCE SECTION.

Figure 46. Typical Application Schematic—Two Microphones, Two Line Inputs, I<sup>2</sup>C and I<sup>2</sup>S Mode

OUTLINE DIMENSIONS

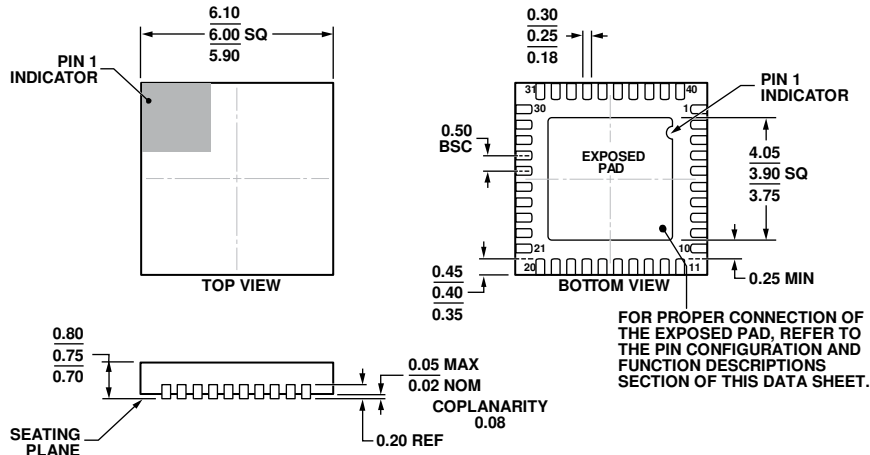

COMPLIANT TO JEDEC STANDARDS MO-220-WJJD.

Figure 47. 40-Lead Lead Frame Chip Scale Package [LFCSP\_WQ]  
6 mm × 6 mm Body, Very Very Thin Quad  
(CP-40-14)  
Dimensions shown in millimeters

05-06-2011-A

ORDERING GUIDE

Model <sup>1, 2</sup>	Temperature Range	Package Description	Package Option
ADAU1977WBCPZ	-40°C to +105°C	40-Lead LFCSP_WQ	CP-40-14
ADAU1977WBCPZ-R7	-40°C to +105°C	40-Lead LFCSP_WQ, 7" Tape and Reel	CP-40-14
ADAU1977WBCPZ-RL	-40°C to +105°C	40-Lead LFCSP_WQ, 13" Tape and Reel	CP-40-14
EVAL-ADAU1977Z		Evaluation Board	

<sup>1</sup> Z = RoHS Compliant Part.

<sup>2</sup> W = Qualified for Automotive Applications.

AUTOMOTIVE PRODUCTS

The ADAU1977W models are available with controlled manufacturing to support the quality and reliability requirements of automotive applications. Note that these automotive models may have specifications that differ from the commercial models; therefore, designers should review the Specifications section of this data sheet carefully. Only the automotive grade products shown are available for use in automotive applications. Contact your local Analog Devices account representative for specific product ordering information and to obtain the specific Automotive Reliability reports for these models.

**NOTES**

**NOTES**