

REV.	DATE	DESCRIPTION
NC	01/22/98	INITIAL RELEASE
A	08/26/07	REVISE BARREL AND FERRULE, UPDATE DRAWING FORMAT

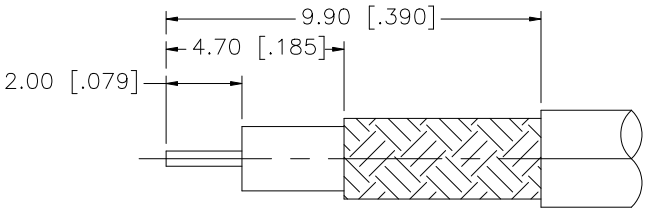

RECOMMENDED CABLE STRIPPING DIMENSIONS

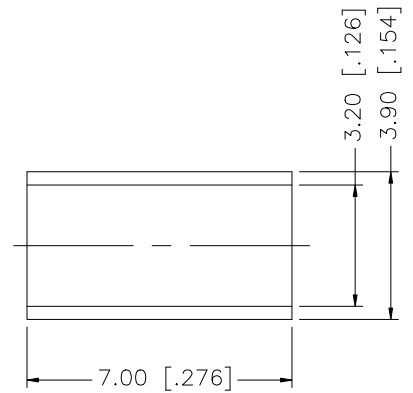
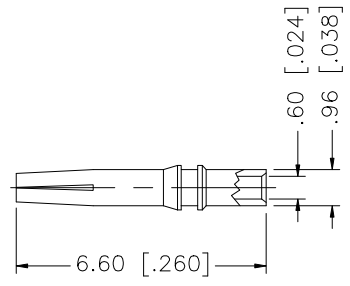
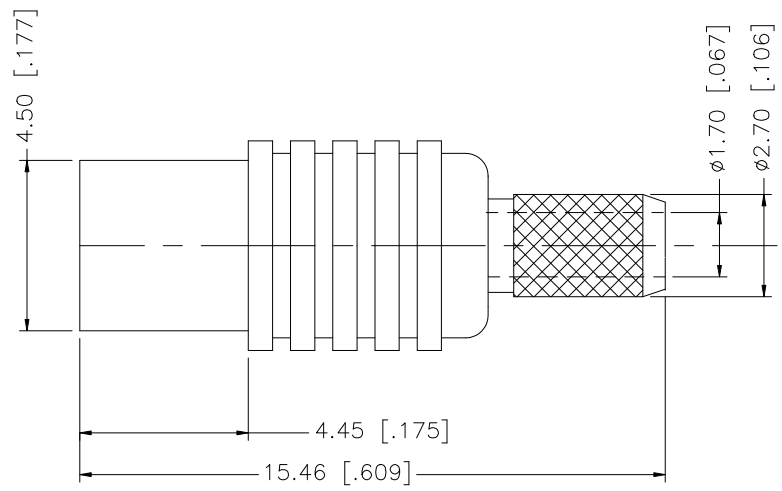

- NOTE:
1. CRIMPED FERRULE HEX CRIMP SIZE .128"
  2. CONTACT PIN TO SOLDER.

8				
7				
6				
5				
4	FERRULE	COPPER	NICKEL	1
3	CONTACT PIN	BER. COPPER	GOLD	1
2	INSULATOR	TEFLON	NATURAL	1
1	BODY	BRASS	NICKEL	1
	DESCRIPTION	MATERIAL	FINISH	QTY

UNLESS OTHERWISE SPECIFIED DIMENSIONS ARE IN MILLIMETERS. DIMENSIONS IN [ ] ARE IN INCHES AND FOR CUSTOMER REFERENCE ONLY.

UNLESS OTHERWISE SPECIFIED TOLERANCES FOR MILLIMETERS ARE:  
0.5 - 8mm ± 0.20mm  
8 - 30mm ± 0.40mm  
30 - 120mm ± 0.50mm

UNLESS OTHERWISE SPECIFIED TOLERANCES FOR INCHES ARE:  
.020 - .315 = ± 0.007"  
.315 - 1.180 = ± 0.015"  
1.180 - 4.724 = ± 0.020"

DO NOT SCALE DRAWING

APPROVALS	DATE
DRAWN G.R.S.	08/26/07
CHECKED	
ISSUED	
SHEET 1 OF 1	
CAD FILE	C:/252/252138.DWG

**Amphenol Connex**

PART DESCRIPTION  
**MCX CRIMP JACK**  
**(FOR RG-174/U, 188A/U, 316/U)**

PART NO.  
**252138**

DWG. NO.	252138.DWG	REV.	A	SIZE	A	SCALE	NA
----------	------------	------	---	------	---	-------	----