

Hybrid Motor With Batteryless Absolute Encoder

M11PM-K



Outline

28mm \square

1.8°/ step

UNIT: $\frac{\text{mm}}{\text{inch}}$

M11PM-K043x	32.5(1.28)	49.0(1.93)
M11PM-K142x	41.0(1.61)	57.0(2.24)
M11PM-K241x	52.0(2.05)	68.0(2.68)

For Motor

PIN NO.	1	2	3	4	5	6
L/W Color	Blu	-	Org	Red	-	Yel
Phase	B	-	\bar{B}	A	-	\bar{A}

For Encoder

PIN NO.	1	2	3	4	5	6	7	8	9	10
L/W Color	Red	Prl	Gry	Wht	Grn	Brn	Yel	Blu	Org	Blk
Signal	Vcc	RS485-	RS485+	PA	NA	PB	NB	PZ	NZ	GND

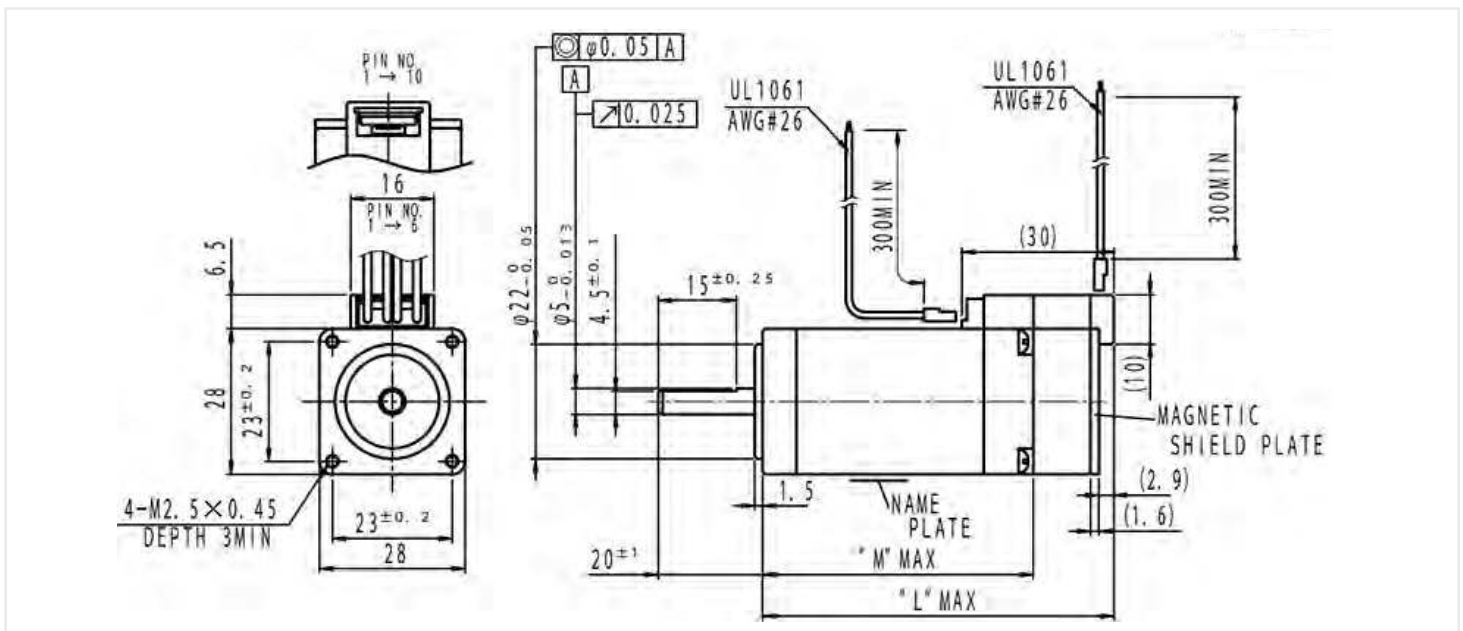
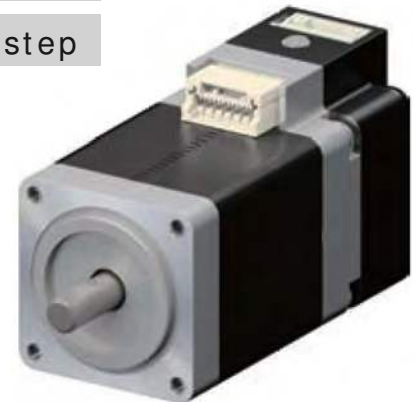

Specifications

MODEL	Step Angle	Drive Sequence	Rated Current	Resistance	Holding Torque	Inductance	Rotor Inertia	Detent Torque	Encoder Resolution	Mass	Max. Turn Count
	(deg)		(A)	(Ohms)	(mNm)	(mH)	(g·cm ²)	(mNm)	CPR		
M11PMK043CMB03	1.8	BI-POLAR	1.5	1.3	100	1.2	8.0	4.4	4000	170	200
M11PMK142CMB03	1.8	BI-POLAR	1.5	1.5	145	1.2	13.0	5.4	4000	200	200
M11PMK241CMB03	1.8	BI-POLAR	1.5	1.7	200	1.8	16.0	8.0	4000	270	200

Torque / Speed Characteristics

Model No: M11PM-K043CMB03

Driver: Chopper Dual
Supply Voltage: 24.0 (Volt)

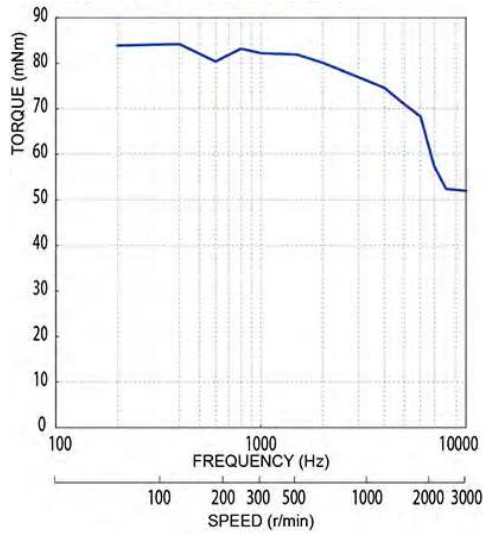

Model No: M11PM-K142CMB03

Driver: Chopper Dual
Supply Voltage: 24.0 (Volt)

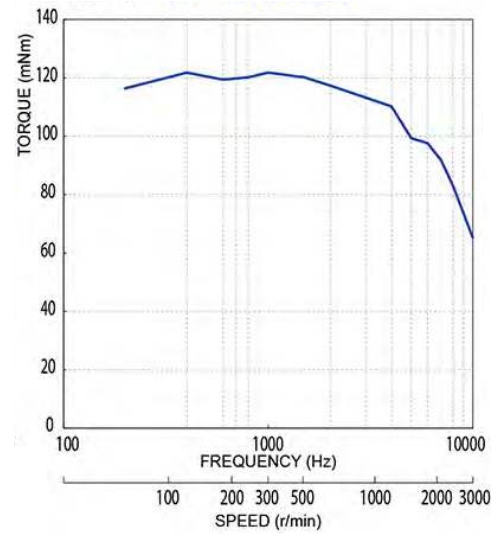

Model No: M11PM-K241CMB03

Driver: Chopper Dual
Supply Voltage: 24.0 (Volt)

