

**SECTION A-A**

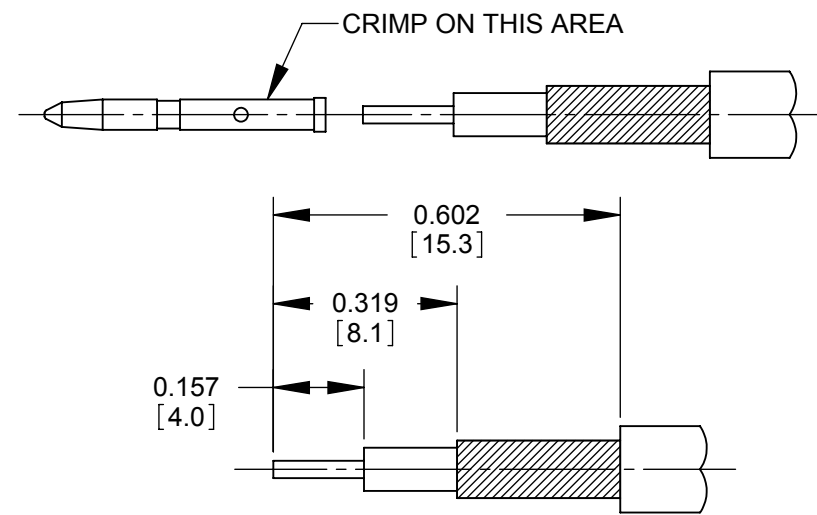

**RECOMMENDED CABLE STRIPPING DIMENSIONS**  
SWITCHCRAFT STRIPPING TOOL #PTS1

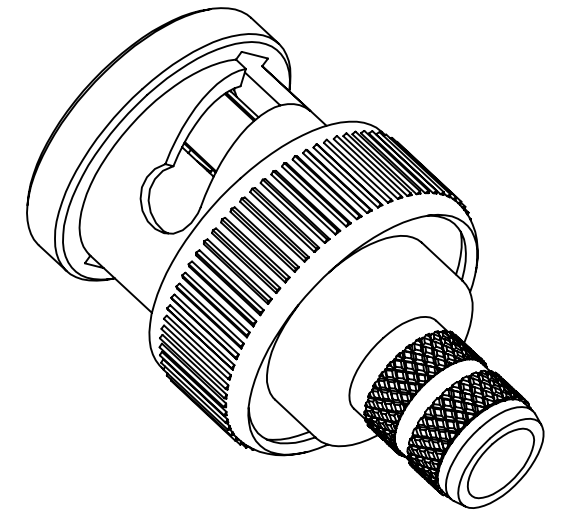
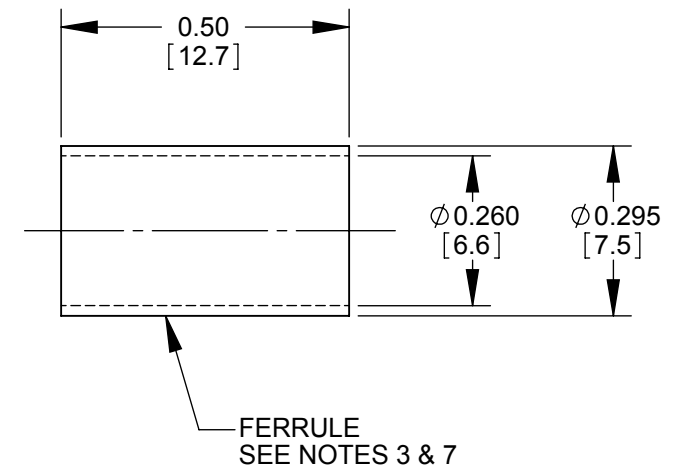
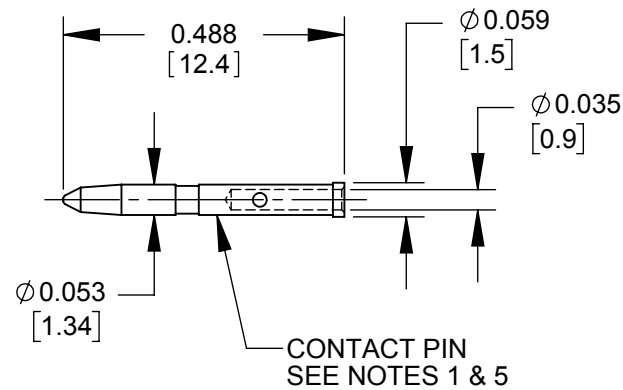

**ALTERNATE KNURL DESIGN**

**NOTES:**

**FINISH (PLATING THICKNESS IN MICRO-INCHES)**

1. BRASS PER QQ-B-626
2. BRASS PER QQ-B-613
3. NICKEL PLATING 100 MIN THICK OVER COPPER STRIKE.
4. NICKEL PLATING 200 MIN THICK OVER COPPER STRIKE.
5. GOLD PLATING 50 MIN THICK OVER NICKEL PLATING 100 MIN THICK OVER COPPER STRIKE.
6. TEFLON MIL-P-19468
7. JIS H 3250, C 2600
8. CRIMPED FERRULE HEX CRIMP SIZE 0.255.
9. CRIMPED CONTACT PIN SQUARE CRIMP SIZE 0.042 OR HEX CRIMP SIZE 0.041.
10. ALL DIMENSIONS ARE FOR REFERENCE ONLY.
11. THIS PRODUCT MEETS SMPTE ST 2082-1.
12. THIS PRODUCT IS RoHS COMPLIANT.

**CUSTOMER DRAWING**

					THIS DRAWING DESCRIBES A DESIGN CONSIDERED PROPRIETARY IN NATURE, DEVELOPED AND MANUFACTURED BY SWITCHCRAFT INC. AND IS RELEASED ON A CONFIDENTIAL BASIS FOR IDENTIFICATION PURPOSES ONLY.						
					UNLESS OTHERWISE SPECIFIED	SIZE	WIDTH	MULT	LBS/M	TEMPER	
					1. ALL DIMENSIONS IN INCHES [mm]	FINISH				MATERIAL	
					- TWO PLACE DECIMALS ±0.02 [0.5]	SPEC No.				SPEC No.	
					- THREE PLACE DECIMALS ±0.005 [0.13]	FIRST USED ON		SCALE		<b>Switchcraft</b> <sup>®</sup>	
						3:1					
B	28086	10-26-18	PC	TJK	DATE DRAWN	BY	CHKD	APVD	SHEET 1 OF 1		
A	27942	11-28-17	PC	TJK	10-17-16	SRC	SRC	TJK	PART No.		
REV	ECO NUMBER	DATE	BY	APVD	NAME UHD BNC CONNECTOR BELDEN 4505R CABLE, RoHS				UHDBNC05		
REVISIONS					DO NOT SCALE DRAWING					REV <b>B</b>	