



actual size

# Oscillator JT33(V) · (VC)TCXO

- Temp. Compensated Crystal Oscillator, 3.2 x 2.5 mm
- low power VCTCXO or TCXO
- temperature range -40 °C ~ +85 °C available
- ± 1.0 ppm stability available
- ceramic/metal package



RoHS compliant



Pb free



REACH compliant



Conflict mineral free

GENERAL DATA		
TYPE	JT33 / JT33V	
frequency range	8.0 ~ 52.0 MHz	
frequency tolerance/ stability	at +25°C	± 1.5 ppm (incl. 2x reflow)
	temperature	± 1 ppm ~ ± 5 ppm (table 1)
	aging first year	± 1 ppm
	supply voltage	± 0.2 ppm (at $V_{DC} \pm 5\%$ )
	load change	± 0.2 ppm
current consumption	2.5 mA max.	
supply voltage $V_{DC}$	1.8 / 2.5 / 2.8 / 3.0 / 3.3 (±5%)	
temperature	operating	see table 1
	storage	-40 °C ~ +85 °C
output	load nom.	10 KΩ // 10 pF
	level min.	0.8 Vpp (clipped sine)
external tuning range JT33V	±8 ppm min.	
external tuning voltage JT33V	0.9 V ± 0.9 V at $V_{DC} = 1.8$ V (standard)	
	1.5 V ± 1.0 V at $V_{DC} \geq 2.5$ V (standard)	
	1.4 V ± 1.0 V at $V_{DC} \geq 2.5$ V (option)	
start-up time max.	2.5 ms	
phase noise	at 100 Hz	-109 dBc/Hz typ.
	at $f_0$	at 1 KHz
26 MHz	at 10 KHz	-148 dBc/Hz typ.

TABLE 1: FREQUENCY STABILITY VS. TEMPERATURE						
operating temperature code	frequency stability code / ppm					
	Y	Z	A	B	C	D
A: -30°C ~ +80°C	○	○	○	○	○	○
B: -20°C ~ +70°C	○	○	○	○	○	○
C: -10°C ~ +60°C	○	○	○	○	○	○
D: 0°C ~ +85°C	○	○	○	○	○	○
E: 0°C ~ +55°C	○	○	○	○	○	○
F: -10°C ~ +70°C	○	○	○	○	○	○
G: -30°C ~ +75°C	○	○	○	○	○	○
H: -20°C ~ +75°C	○	○	○	○	○	○
K: -40°C ~ +85°C	○	○	○	○	○	○
L: -20°C ~ +85°C	○	○	○	○	○	○
M: -30°C ~ +85°C	○	○	○	○	○	○

○ on request

NOTE
- TCXO JT33: pin #1 connected to GND
- VCTCXO JT33V: pin #1 is control voltage $V_C$
- external AC coupling for output recommended

DIMENSIONS					
				TCXO JT33 # 1: GND # 2: GND # 3: output # 4: $V_{DC}$	VCTCXO JT33V # 1: $V_{control}$ # 2: GND # 3: output # 4: $V_{DC}$
top view	side view	bottom view	pad layout	pin connection	in mm

ORDER INFORMATION						
<b>0</b>	frequency	type	frequency stability code	operating temp. code	supply voltage	control voltage (for JT33V only)
Oscillator	8.0 ~ 45.0 MHz	JT33 = TCXO JT33V = VCTCXO	A - Z see table 1	A - M see table 1	1.8 = 1.8 V 2.5 = 2.5 V 2.8 = 2.8 V 3.0 = 3.0 V 3.3 = 3.3 V	$0.9 = V_C$ $0.9 V \pm 0.9 V$ at $V_{DC} = 1.8 V$ $1.5 = V_C$ $1.5 V \pm 1.0 V$ at $V_{DC} \geq 2.5 V$ $1.4 = V_C$ $1.4 V \pm 1.0 V$ at $V_{DC} \geq 2.5 V$ see General Data
<b>Example: 0 26.0-JT33V-A-G-3.3-1.5-LF</b> (Suffix LF = RoHS compliant / Pb free)						

# Oscillator JT33(V) · (VC)TCXO

## TAPING SPECIFICATION

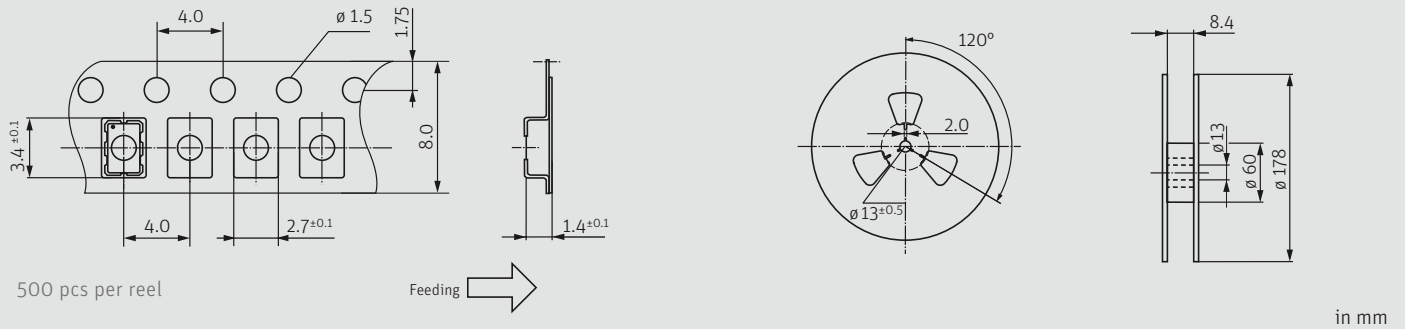

## REFLOW SOLDERING PROFILE

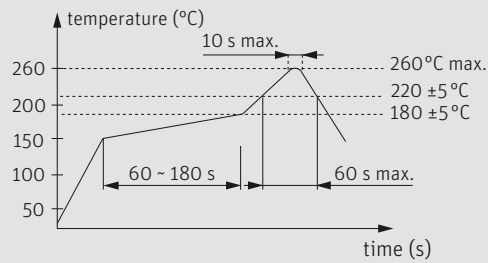

note: parts are also suitable for soldering systems with lead (Pb) content

## MARKING

### frequency

company code / stability code / voltage code / date code

date code: A ~ M: Jan. - Dec.

9: 2019    0: 2020    1: 2021    2: 2022    3: 2023    4: 2024

Jan.	Febr.	Mar.	Apr.	May	June
A	B	C	D	E	F
July	Aug.	Sept.	Oct.	Nov.	Dec.
G	H	J	K	L	M

## PACKAGING NOTE

- standard packing unit is 500 pieces per reel
- non-multiple packing units are only supplied taped / bulk