

# C-100MM Fast Ethernet Fiber to Fiber Media Converter Modules

---

 [perle.com/products/fast-ethernet-fiber-converter-modules.shtml](http://perle.com/products/fast-ethernet-fiber-converter-modules.shtml)

## Unmanaged



- 100Base-FX to 100Base-X Fiber to Fiber Media Converter Module
- Multimode to multimode or multimode to single mode
- Extend multimode fiber to 120km ( or more through chaining )
- Choice in SC, LC and ST fiber connector models
- Signal regeneration prevents signal degradation
- Advanced Features: [Link Pass-Through](#), Far-End Fault, loopback for each fiber connection
- High density applications with Perle [Media Converter Chassis](#)

Installed in a high density [Perle Media Converter Chassis](#), Perle's feature rich **C-100MM Fast Ethernet Fiber to Fiber** Media Converter Module enables transparent fiber extension of 100Base-FX multimode fiber to 100Base-FX multimode or 100Base-LX/EX/ZX/BX single mode fiber.

Perle's advanced features make the end to end fiber link completely transparent. This allows for more efficient troubleshooting and less on-site maintenance. In addition, a lifetime warranty and free worldwide technical support make **Perle's C-100MM Fast Ethernet Fiber to Fiber Media Converter Modules** the smart choice for IT professionals.

Whether you need to extend **multimode to multimode** or **multimode to single mode**, Perle has an extensive range of C-100MM Fast Ethernet Fiber to Fiber Media Converter Modules to meet your fiber conversion requirement.

## C-100MM Fiber to Fiber Features: 100Base-FX to 100Base-X

### [Link Pass-Through](#)

When enabled, the state of the receiver on one 100Base-X interface is reflected on the other 100Base-X fiber transmitter.

If disabled, the 100Base-X fiber interfaces operate independently. Far-End Fault indication on the 100Base-FX fiber interface has no effect on the other interface.

Using Link Pass-Through with Far-End Fault minimizes data loss when a fault occurs. If a fault occurs, the end devices have the indication of a failure available to making trouble shooting easier.

Far-End Fault (FEF)	<p>When enabled, the media converter transmits the Far-End Fault Indication over the fiber connection whenever a receive failure is detected. The media converter continuously monitors the fiber connection and clears the Far-End Fault Indication condition when a valid signal is received.</p> <p>When disabled, Far-End Fault Indications are not transmitted regardless of the condition of the receive signal on the 100Base-X fiber connection.</p> <p>The action the media converter takes on receiving a Far-End Fault Indication is dependent on the Link Pass Through switch setting.</p>
Signal Regeneration	Signal regeneration maintains signal integrity and allows for maximum fiber to fiber connections without degradation.
Cascading	Media Converters can be cascaded. Two or more media converters can be chained in a link to achieve even greater distances.
Pause (IEEE 802.3xy)	Pause signaling is an IEEE feature that temporarily suspends data transmission between two devices in the event that one of the devices becomes overwhelmed. The media converter is transparent to Pause frames.
VLAN	The Media Converter is transparent to 802.1Q VLAN tagged packets.
Remote Loopback	The Media Converter can perform a loopback on each 100Base-X fiber interface.

### Indicators

Power / TST	This green LED is turned on when power is applied to the media converter. Otherwise it is off. The LED will blink slowly when in Loopback test mode.
Fiber link 1 / Receive activity (LK1)	This green LED is operational only when power is applied. The LED is on when the 100Base-X link is on and flashes with a 50% duty cycle when data is received.
Fiber link 2 on / Receive activity (LK2)	This green LED is operational only when power is applied. The LED is on when the 100Base-X link is on and flashes with a 50% duty cycle when data is received.

### Switches: On-Board

Link Pass Through	<p><i>Enabled (Default)</i> - When the state of the receiver is changed on one of the 100Base-X interfaces it is reflected on the other 100Base-X fiber transmitter.</p> <p>If disabled, the 100Base-X fiber interfaces operate independently. Far-End Fault indication on the 100Base-FX fiber interface has no effect on the other interface.</p>
Far-End Fault (FEF)	<p><i>Enabled ( default )</i> - The media converter transmits the Far-End Fault Indication over the fiber connection whenever a receive failure is detected. The media converter continuously monitors the fiber connection and clears the Far-End Fault Indication condition when a valid signal is received.</p> <p><i>When Disabled</i>, Far-End Fault Indications are not transmitted regardless of the condition of the receive signal on the 100Base-X fiber connection.</p>

---

Remote Loopback #1      The media converter can perform a loopback on the link #1 fiber interface.  
*Disabled (Default - Up)*

*Enabled* - The 100Base-X receiver is looped to the 100Base-X transmitter. Link #2's fiber transmitter is taken off the interface

---

Remote Loopback #2      The media converter can perform a loopback on the link #2 fiber interface.

*Disabled (Default - Up)*

*Enabled* - The 100Base-X receiver is looped to the 100Base-X transmitter. Link #1's fiber transmitter is taken off the interface.

---

### Cables

---

Fiber Optic Cable      Multimode: 62.5 / 125, 50/125, 85/125, 100/140 micron  
Single Mode: 9/125 micron (ITU-T 625)

---

### Packet Transmission Characteristics

---

Bit Error Rate (BER)      <10<sup>-12</sup>

---

### Environmental Specifications

---

Operating Temperature      0 C to 50 C (32 F to 122 F)

---

Storage Temperature      minimum range of -25 C to 70 C (-13 F to 158 F)

---

Operating Humidity      5% to 90% non-condensing

---

Storage Humidity      5% to 95% non-condensing

---

Operating Altitude      Up to 3,048 meters (10,000 feet)

---

Heat Output ( BTU/HR )      11.9

---

Maximum Power Consumption ( Watts )      3.5

---

MTBF (Hours)\*      489,076

---

### Mechanical - Hot Swapping Card

---

Edge Connector      32 pin DIN 41612 / IEC 60603-2 Type B/2 Male. First make, last break for ground and power

---

Card insertion and removal	Captive thumb screws enable fast insertion and removal. Can be further tighten with a screwdriver.
<b>Product Weight</b>	
Weight	0.15 kg, 0.33 lbs
<b>Packaging</b>	
Shipping Weight	0.33 kg, .73 lbs
Shipping Dimensions	203 x 38 x 152 mm, 8 x 1.5 x 6 inches
<b>Regulatory Approvals</b>	
Emissions	FCC Part 15 Class A, EN55022 Class A
	CISPR 22 Class A
	EN61000-3-2
Immunity	EN55024
Electrical Safety	UL 60950-1
	EN60950
	CE
Laser Safety	EN 60825-1:2007
	Fiber optic transmitters on this device meet Class 1 Laser safety requirements per IEC-60825 FDA/CDRH standards and comply with 21CFR1040.10 and 21CFR1040.11.
Environmental	<a href="#">Reach, RoHS and WEEE Compliant</a>
Other	ECCN: 5A991
	HTSUS Number: 8517.62.0050
	Perle Limited Lifetime Warranty

\*Calculation model based on MIL-HDBK-217-FN2 @ 30 °C

### High Density Fiber Distribution from Fiber Switch Equipment at Corporate Headquarters

In this enterprise campus application, up to 19 Perle Fiber to Fiber Media Converters ( Multimode to Single mode ) are installed in the MCR1900 Media Converter Chassis. A remote single mode fiber enabled Ethernet switch is connected directly to the central MCR1900 Chassis. Another standalone Fiber Media Converter is connected to a remote office Fiber switch. In all cases, multimode or single-mode fiber can be used. Fiber links can be extended up to 120km using single-mode fiber.

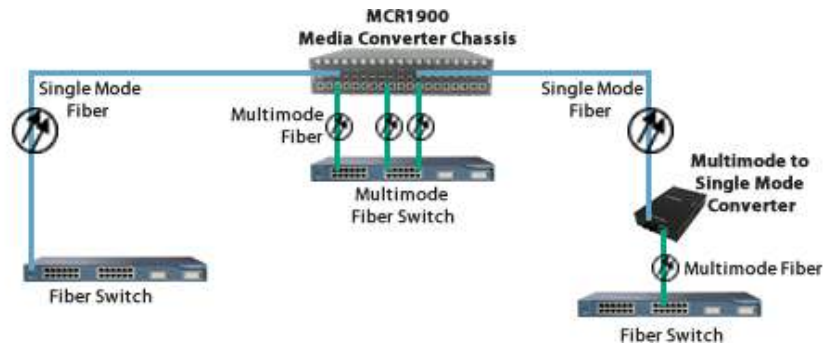

### Fast Ethernet Fiber Switch to Fiber Switch

#### Extend the network distance between two Multimode Fiber switches

Two Fiber to Fiber Media Converters can extend the distance between Fiber Switches across a single mode fiber link up to 120km in length.



### Single Mode / Single Fiber

**Connect fiber ports over a single fiber strand ( also referred to as “Bi-Directional” BiDi )**

When Single Strand fiber is used, a pair of Single Fiber Media Converters is needed for the fiber to fiber conversion. Perle Single Fiber Media Converters are also referred to as “Up/Down” models. For example the C-100MM-S1SC20U (“Up”) and C-100MM-S1SC20D (“Down”), shown below, must be used in pairs. An “Up” must be matched with a “Down” peer to deal with transmit and receive frequencies separately.

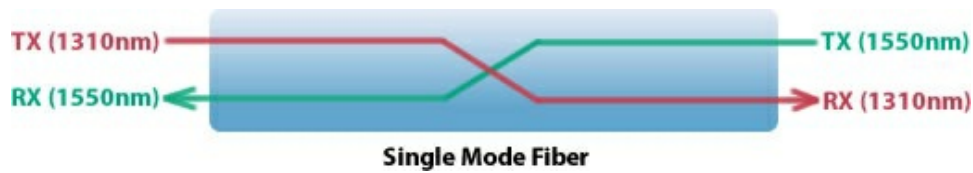

**C-100MM-S1SC20UC-100MM-S1SC20D**

The majority of installations for single mode fiber media converters are of the “dual connector” or “dual fiber” type where one fiber connection is used for transmit, the other for receive. These are physically “crossed” to match up the Transmit/Receive links.

However, to reduce costs, or where there are limits on available fiber, WDM technology may be utilized. WDM uses separate transmit and receive frequencies to communicate on a single fiber strand. WDM technology relies on the fact that optical fibers can carry many wavelengths of light simultaneously without interaction between each wavelength. Thus, a single fiber can carry many separate wavelength signals or channels simultaneously.

So remember, if Single Strand fiber is used, you will need an “Up” Media Converter on one side and a “Down” Media Converter on the other for fiber to fiber conversion.

Perle offers a wide variety of Single Fiber (“Up/Down”) Media Converters to connect 10BaseT, Fast Ethernet and Gigabit to single fiber. Whether you need Managed or Unmanaged, Standalone or Modular Chassis Based, 20km or 120km, Perle has the right model to meet your fiber conversion requirement.

**Select a Model to obtain a Part Number - C-100MM Fast Ethernet Fiber to Fiber Media Converter Module**

Model	Port	Connector	Type	Transmit (dBm)		Receive (dBm)		Power Budget (dBm)	Wavelength (nm)	Fiber Type	Operating Distance
				Min	Max	Min	Max				
C-100MM-M2ST2	Port 1	Dual ST	100BASE-FX	-20.0	-12.0	-31.0	-14.0	11.0*	1310	MMF	2 km (1.2 mi)
	Port 2	Dual ST	100BASE-FX	-20.0	-12.0	-31.0	-14.0	11.0*	1310	MMF	2 km (1.2 mi)
C-100MM-M2SC2	Port 1	Dual SC	100BASE-FX	-20.0	-12.0	-31.0	-14.0	11.0*	1310	MMF	2 km (1.2 mi)
	Port 2	Dual SC	100BASE-FX	-20.0	-12.0	-31.0	-14.0	11.0*	1310	MMF	2 km (1.2 mi)
C-100MM-M2LC2	Port 1	Dual LC	100BASE-FX	-20.0	-12.0	-30.0	-14.0	10.0*	1310	MMF	2 km (1.2 mi)
	Port 2	Dual LC	100BASE-FX	-20.0	-12.0	-30.0	-14.0	10.0*	1310	MMF	2 km (1.2 mi)

C-100MM-S2ST20	Port 1	Dual ST	100BASE-FX	-20.0	-12.0	-31.0	-14.0	11.0*	1310	MMF	2 km (1.2 mi)
	Port 2	Dual ST	100BASE-LX	-18.0	-7.0	-32.0	-3.0	14.0	1310	SMF	20 km (12.4 mi)
C-100MM-S2SC20	Port 1	Dual SC	100BASE-FX	-20.0	-12.0	-31.0	-14.0	11.0*	1310	MMF	2 km (1.2 mi)
	Port 2	Dual SC	100BASE-LX	-18.0	-7.0	-32.0	-3.0	14.0	1310	SMF	20 km (12.4 mi)
C-100MM-S2LC20	Port 1	Dual LC	100BASE-FX	-20.0	-12.0	-30.0	-14.0	10.0*	1310	MMF	2 km (1.2 mi)
	Port 2	Dual LC	100BASE-LX	-15.0	0.0	-34.0	-5.0	19.0	1310	SMF	20 km (12.4 mi)
C-100MM-S2ST40	Port 1	Dual ST	100BASE-FX	-20.0	-12.0	-31.0	-14.0	11.0*	1310	MMF	2 km (1.2 mi)
	Port 2	Dual ST	100BASE-EX	-5.0	0.0	-34.0	-3.0	29.0	1310	SMF	40 km (25 mi)
C-100MM-S2SC40	Port 1	Dual SC	100BASE-FX	-20.0	-12.0	-31.0	-14.0	11.0*	1310	MMF	2 km (1.2 mi)
	Port 2	Dual SC	100BASE-EX	-5.0	0.0	-34.0	-3.0	29.0	1310	SMF	40 km (25 mi)
C-100MM-S2LC40	Port 1	Dual LC	100BASE-FX	-20.0	-12.0	-30.0	-14.0	10.0*	1310	MMF	2 km (1.2 mi)
	Port 2	Dual LC	100BASE-EX	-5.0	0.0	-34.0	-3.0	29.0	1310	SMF	40 km (25 mi)
C-100MM-S2ST80	Port 1	Dual ST	100BASE-FX	-20.0	-12.0	-31.0	-14.0	11.0*	1310	MMF	2 km (1.2 mi)
	Port 2	Dual ST	100BASE-ZX	-5.0	0.0	-34.0	-3.0	29.0	1550	SMF	80 km (50 mi)
C-100MM-S2SC80	Port 1	Dual SC	100BASE-FX	-20.0	-12.0	-31.0	-14.0	11.0*	1310	MMF	2 km (1.2 mi)
	Port 2	Dual SC	100BASE-ZX	-5.0	0.0	-34.0	-3.0	29.0	1550	SMF	80 km (50 mi)
C-100MM-S2LC80	Port 1	Dual LC	100BASE-FX	-20.0	-12.0	-30.0	-14.0	10.0*	1310	MMF	2 km (1.2 mi)
	Port 2	Dual LC	100BASE-ZX	-5.0	0.0	-34.0	-3.0	29.0	1550	SMF	80 km (50 mi)
C-100MM-S2ST120	Port 1	Dual ST	100BASE-FX	-20.0	-12.0	-31.0	-14.0	11.0*	1310	MMF	2 km (1.2 mi)

	Port 2	Dual ST	100BASE-ZX	0.0	5.0	-35.0	-3.0	35.0	1550	SMF	120 km (75 mi)
C-100MM-S2SC120	Port 1	Dual SC	100BASE-FX	-20.0	-12.0	-31.0	-14.0	11.0*	1310	MMF	2 km (1.2 mi)
	Port 2	Dual SC	100BASE-ZX	0.0	5.0	-35.0	-3.0	35.0	1550	SMF	120 km (75 mi)
C-100MM-S2LC120	Port 1	Dual LC	100BASE-FX	-20.0	-12.0	-30.0	-14.0	10.0*	1310	MMF	2 km (1.2 mi)
	Port 2	Dual LC	100BASE-ZX	0.0	5.0	-34.0	-3.0	34.0	1550	SMF	120 km (75 mi)

### Single Fiber Models ( Recommended use in pairs )

Model	Port	Connector	Type	Transmit (dBm)		Receive (dBm)		Power Budget (dBm)	Wavelength (nm)	Fiber Type	Operating Distance
				Min	Max	Min	Max				
C-100MM-S1ST20U	Port 1	Dual ST	100BASE-FX	-20.0	-12.0	-31.0	-14.0	11.0*	1310	MMF	2 km (1.2 mi)
	Port 2	Single ST	100BASE-BX	-14.0	-8.0	-32.0	-3.0	18.0	1310/1550	SMF	20 km (12.4 mi)
C-100MM-S1ST20D	Port 1	Dual ST	100BASE-FX	-20.0	-12.0	-31.0	-14.0	11.0*	1310	MMF	2 km (1.2 mi)
	Port 2	Single ST	100BASE-BX	-14.0	-8.0	-32.0	-3.0	18.0	1550/1310	SMF	20 km (12.4 mi)
C-100MM-S1SC20U	Port 1	Dual SC	100BASE-FX	-20.0	-12.0	-31.0	-14.0	11.0*	1310	MMF	2 km (1.2 mi)
	Port 2	Single SC	100BASE-BX	-14.0	-8.0	-32.0	-3.0	18.0	1310/1550	SMF	20 km (12.4 mi)
C-100MM-S1SC20D	Port 1	Dual SC	100BASE-FX	-20.0	-12.0	-31.0	-14.0	11.0*	1310	MMF	2 km (1.2 mi)
	Port 2	Single SC	100BASE-BX	-14.0	-8.0	-32.0	-3.0	18.0	1550/1310	SMF	20 km (12.4 mi)
C-100MM-S1SC40U	Port 1	Dual SC	100BASE-FX	-20.0	-12.0	-31.0	-14.0	11.0*	1310	MMF	2 km (1.2 mi)
	Port 2	Single SC	100BASE-BX	-8.0	-3.0	-33.0	-3.0	25.0	1310/1550	SMF	40 km (25 mi)
C-100MM-S1SC40D	Port 1	Dual SC	100BASE-FX	-20.0	-12.0	-31.0	-14.0	11.0*	1310	MMF	2 km (1.2 mi)
	Port 2	Single SC	100BASE-BX	-8.0	-3.0	-33.0	-3.0	25.0	1550/1310	SMF	40 km (25 mi)

The minimum fiber cable distance for all converters listed is 2 meters.

\*Based on use with 62.5/125 micron multimode fiber.