

THIS DRAWING IS UNPUBLISHED. RELEASED FOR PUBLICATION
 © COPYRIGHT - By - ALL RIGHTS RESERVED.

LOC		DIST		REVISIONS			
P	LTR	DESCRIPTION		DATE	DWN	APVD	
AD	00	E3	REVISED PER ECR-13-018488	26NOV13	W.W	C.W	

SPECIFICATIONS:

MATERIALS-
 INSULATOR: UL94V-0 (SEE TABLE FOR MATERIAL)
 CONTACT: BERYLLIUM COPPER (SEE TABLE FOR PLATING)

ELECTRICAL-
 CONTACT RESISTANCE: GOLD - 15 MILLIOHMS, PER MIL-STD-12883
 TIN- 25 MILLIOHMS MAX

CONTACT RATING: 10 AMPS DC
 DIELECTRIC WITHSTANDING VOLTAGE- 1500 VOLTS(RMS)

MECHANICAL-
 OPERATIONAL TEMPERATURE: DAP -67F TO +257F
 (-55C TO +125C)

NOTES

1. INTERPRET DRAWING PER ASME Y14.5M-1994.
2. THIS ASSEMBLY IS INTENDED FOR USE WITH SEMI-CONDUCTORS PACKAGED WITHIN THE OUTLINE DIMENSIONS OF THE "TO-3".
3. LUG(S) IS AN INTEGRAL PART OF SADDLE.
4. .000200 MIN THK TIN-LEAD PLATE OVER .000100 MIN THK COPPER PLATE.
5. .000030 MIN THK GOLD PLATE OVER .000050 MIN THK NICKEL PLATE.
6. .000500 MIN THK SILVER PLATE.
7. .000050 MIN THK GOLD PLATE OVER .000050 MIN THK NICKEL PLATE.
8. .000200 MIN THK TIN (LEAD FREE) PLATE OVER .000100 MIN THK COPPER PLATE.

9 OBSOLETE PARTS: OBSOLETE CIS STREAMLINING PER D.RENAUD/D.SINISI

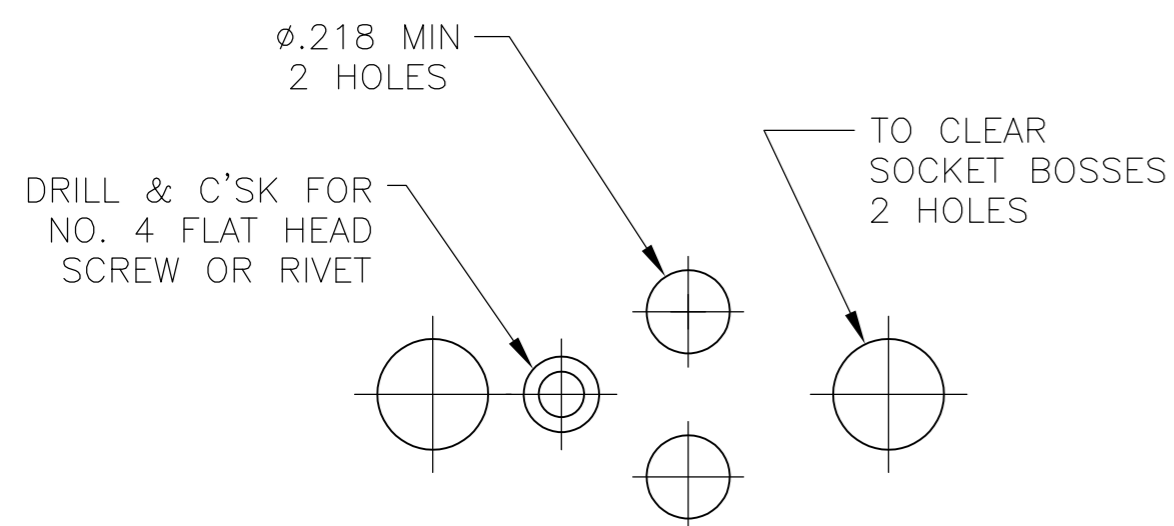
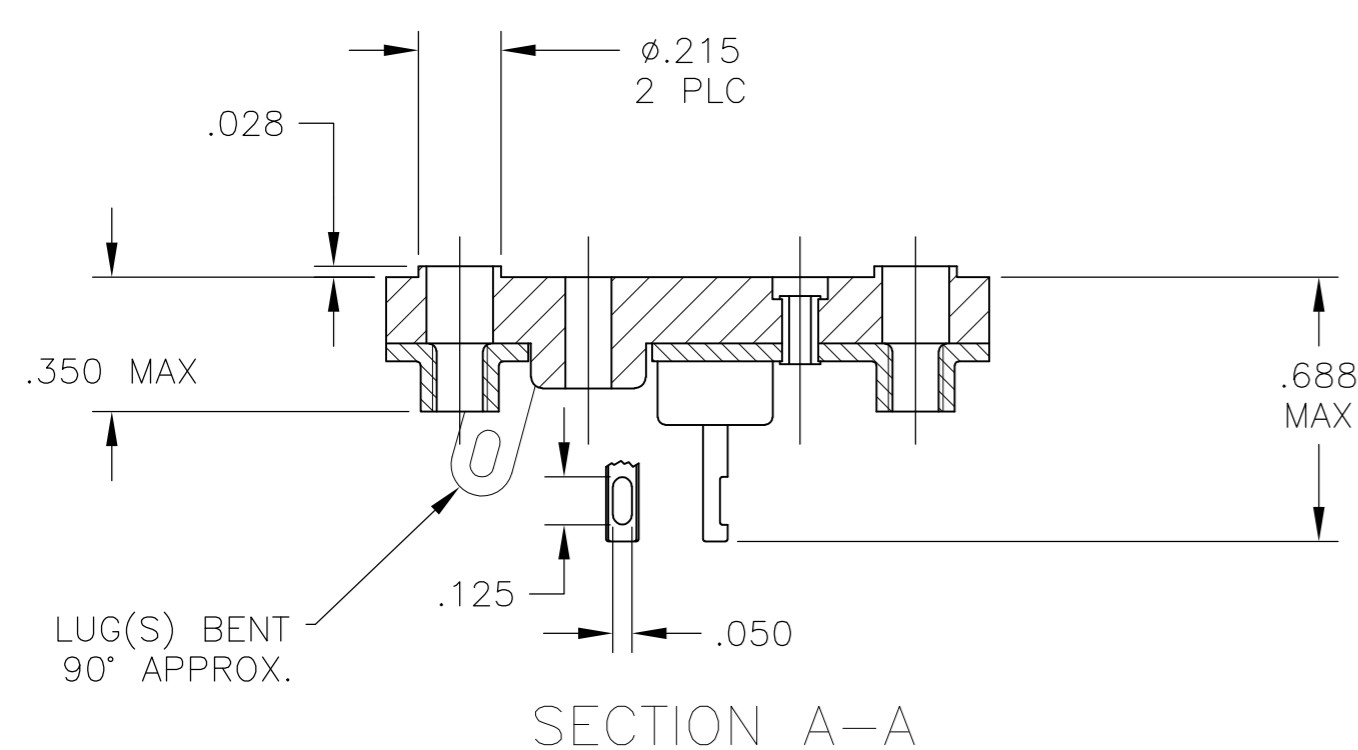
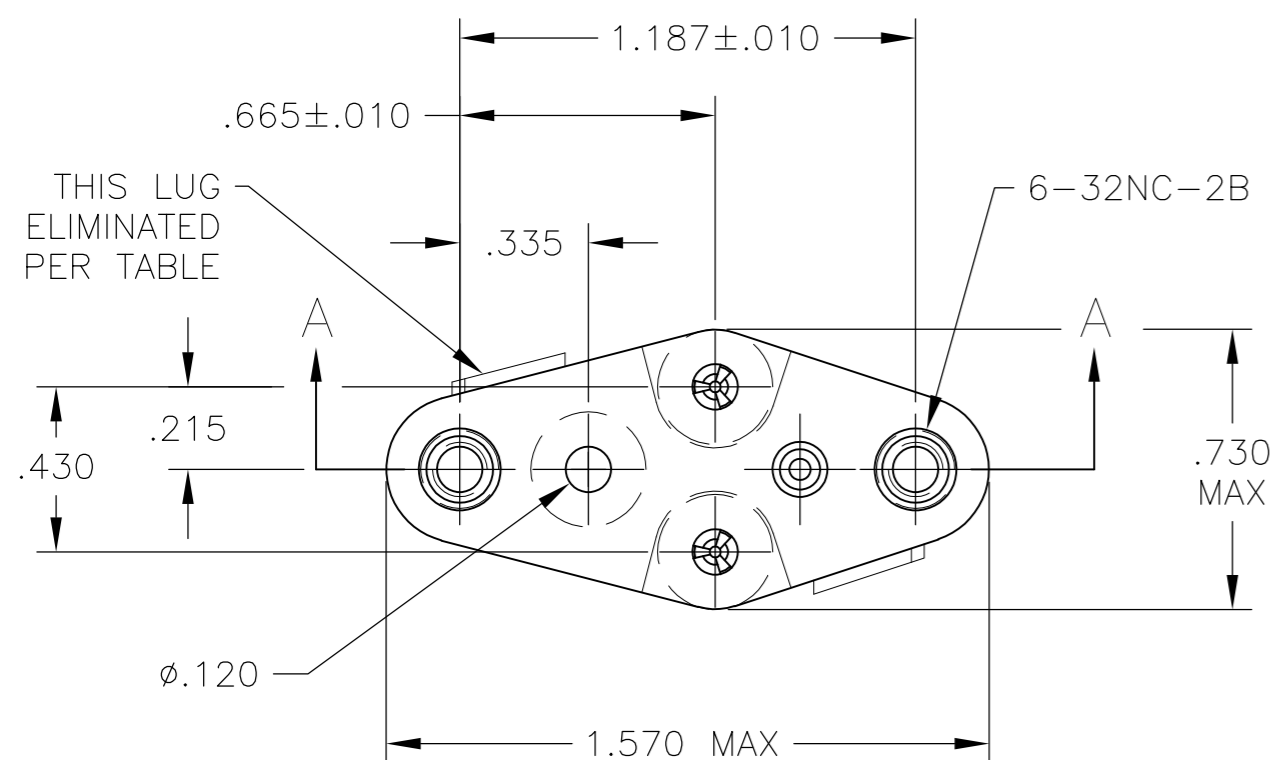

RECOMMENDED CHASSIS HOLE LAYOUT

QTY	LEAD DIA	INSULATOR MATERIAL/COLOR	CONTACT PLATING	AUGAT PT. NO. (REFERENCE)	PT. NO.	
1	.040+.003/-0.002	DIALLYL PHTHALATE-GREEN OR BLUE	NOTE 5	8080-1G9-LF	5-6437504-5	
2	.040+.003/-0.002	DIALLYL PHTHALATE-GREEN OR BLUE	NOTE 5	8080-1G7-LF	5-6437504-3	
2	.040+.003/-0.002	DIALLYL PHTHALATE-GREEN OR BLUE	NOTE 8	8080-1G5-LF	5-6437504-2	
1	.040+.003/-0.002	DIALLYL PHTHALATE-GREEN OR BLUE	NOTE 6	8080-1G4-LF	5-6437504-0	
2	.040-.060	PHENOLIC-BLACK	NOTE 8	8080-1G20-LF	8-1437504-9	
2	.040+.003/-0.002	DIALLYL PHTHALATE-GREEN	NOTE 7	8080-1G19-LF	8-1437504-6	
2	.040-.060	PHENOLIC-BLACK	NOTE 8	8080-1G15-LF	8-1437504-3	
1	.040-.060	PHENOLIC-BLACK	NOTE 8	8080-1G14-LF	8-1437504-2	
2	.040+.003/-0.002	DIALLYL PHTHALATE-GREEN	NOTE 5	8080-1G10-LF	8-1437504-0	
2	.040-.060	DIALLYL PHTHALATE-GREEN OR BLUE	NOTE 6	8080-1G16-LF	6-1437504-6	
2	.040+.003/-0.002	DIALLYL PHTHALATE-GREEN OR BLUE	NOTE 8	8080-1G3-LF	6-1437504-5	
2	.040+.003/-0.002	DIALLYL PHTHALATE-GREEN OR BLUE	NOTE 6	8080-1G2-LF	6-1437504-4	
2	.040+.003/-0.002	DIALLYL PHTHALATE-GREEN OR BLUE	NOTE 8	8080-1G1-LF	6-1437504-3	
SUPERSEDED	1	.040+.003/-0.002	DIALLYL PHTHALATE-GREEN OR BLUE	NOTE 7	8080-1G18	5-1437504-9
1	.040+.003/-0.002	DIALLYL PHTHALATE-GREEN OR BLUE	NOTE 5	8080-1G9	5-1437504-5	
2	.040+.003/-0.002	DIALLYL PHTHALATE-GREEN OR BLUE	NOTE 5	8080-1G7	5-1437504-3	
2	.040+.003/-0.002	DIALLYL PHTHALATE-GREEN OR BLUE	NOTE 4	8080-1G5	5-1437504-2	
1	.040+.003/-0.002	DIALLYL PHTHALATE-GREEN OR BLUE	NOTE 6	8080-1G4	5-1437504-0	
1	.040+.003/-0.002	PHENOLIC-BLACK	NOTE 4	8080-1G3	4-1437504-2	
9 OBSOLETE	2	.040-.060	PHENOLIC-BLACK	NOTE 4	8080-1G20	3-1437504-9
2	.040+.003/-0.002	DIALLYL PHTHALATE-GREEN OR BLUE	NOTE 6	8080-1G2	3-1437504-8	
2	.040+.003/-0.002	DIALLYL PHTHALATE-GREEN OR BLUE	NOTE 7	8080-1G19	3-1437504-6	
2	.040-.060	DIALLYL PHTHALATE-GREEN OR BLUE	NOTE 6	8080-1G16	3-1437504-4	
2	.040-.060	PHENOLIC-BLACK	NOTE 4	8080-1G15	3-1437504-3	
1	.040-.060	PHENOLIC-BLACK	NOTE 4	8080-1G14	3-1437504-2	
2	.040+.003/-0.002	DIALLYL PHTHALATE-GREEN OR BLUE	NOTE 4	8080-1G13	3-1437504-1	
2	.040+.003/-0.002	DIALLYL PHTHALATE-GREEN OR BLUE	NOTE 5	8080-1G10	3-1437504-0	
2	.040+.003/-0.002	DIALLYL PHTHALATE-GREEN OR BLUE	NOTE 4	8080-1G1	2-1437504-9	

THIS DRAWING IS A CONTROLLED DOCUMENT. DWN R BROWN 31MAR05
 CHK K WRIGHT 31MAR05
 APVD K WRIGHT 31MAR05

STE TE Connectivity

NAME: TRANSISTOR SOCKET

SIZE: A2 CAGE CODE: 00779 DRAWING NO: 2-1437504-9 RESTRICTED TO: -

MATERIAL: SEE NOTES FINISH: SEE NOTES WEIGHT: - SCALE: 2:1 SHEET: 1 of 1 REV: E3

CUSTOMER DRAWING