

| PART NUMBER DATA |       |       |       |        |        |        |      |       |  |
|------------------|-------|-------|-------|--------|--------|--------|------|-------|--|
| CIRCUITS         | A IN  | mm    | B IN  | mm     | C IN   | mm     | D IN | mm    |  |
| 2                | 1.58  | 40.2  | .375  | 9.52   | 1.125  | 28.58  | .83  | 21.1  |  |
| 3                | 1.96  | 49.7  | .750  | 19.05  | 1.500  | 38.10  | 1.21 | 30.7  |  |
| 4                | 2.33  | 59.2  | 1.125 | 28.58  | 1.875  | 47.63  | 1.58 | 40.2  |  |
| 5                | 2.71  | 68.7  | 1.500 | 38.10  | 2.250  | 57.15  | 1.96 | 49.7  |  |
| 6                | 3.08  | 78.3  | 1.875 | 47.63  | 2.625  | 66.68  | 2.33 | 59.2  |  |
| 7                | 3.46  | 87.8  | 2.250 | 57.15  | 3.000  | 76.20  | 2.71 | 68.8  |  |
| 8                | 3.83  | 97.3  | 2.625 | 66.68  | 3.375  | 85.73  | 3.08 | 78.3  |  |
| 9                | 4.21  | 106.8 | 3.000 | 76.20  | 3.750  | 95.25  | 3.46 | 87.8  |  |
| 10               | 4.58  | 116.4 | 3.375 | 85.73  | 4.125  | 104.78 | 3.83 | 97.3  |  |
| 11               | 4.96  | 125.9 | 3.750 | 95.25  | 4.500  | 114.30 | 4.21 | 106.9 |  |
| 12               | 5.33  | 135.4 | 4.125 | 104.78 | 4.875  | 123.83 | 4.58 | 116.4 |  |
| 13               | 5.71  | 144.9 | 4.500 | 114.30 | 5.250  | 133.35 | 4.96 | 125.9 |  |
| 14               | 6.08  | 154.5 | 4.875 | 123.83 | 5.625  | 142.88 | 5.33 | 135.4 |  |
| 15               | 6.46  | 164.0 | 5.250 | 133.35 | 6.000  | 152.40 | 5.71 | 145.0 |  |
| 16               | 6.83  | 173.5 | 5.625 | 142.88 | 6.375  | 161.93 | 6.08 | 154.5 |  |
| 17               | 7.21  | 183.0 | 6.000 | 152.40 | 6.750  | 171.45 | 6.46 | 164.0 |  |
| 18               | 7.58  | 192.6 | 6.375 | 161.93 | 7.125  | 180.98 | 6.83 | 173.5 |  |
| 19               | 7.96  | 202.1 | 6.750 | 171.45 | 7.500  | 190.50 | 7.21 | 183.1 |  |
| 20               | 8.33  | 211.6 | 7.125 | 180.98 | 7.875  | 200.03 | 7.58 | 192.6 |  |
| 21               | 8.71  | 221.1 | 7.500 | 190.50 | 8.250  | 209.55 | 7.96 | 202.1 |  |
| 22               | 9.08  | 230.7 | 7.875 | 200.03 | 8.625  | 219.08 | 8.33 | 211.6 |  |
| 23               | 9.46  | 240.2 | 8.250 | 209.55 | 9.000  | 228.60 | 8.71 | 221.2 |  |
| 24               | 9.83  | 249.7 | 8.625 | 219.08 | 9.375  | 238.13 | 9.08 | 230.7 |  |
| 25               | 10.21 | 259.2 | 9.000 | 228.60 | 9.750  | 247.65 | 9.46 | 240.2 |  |
| 26               | 10.58 | 268.8 | 9.375 | 238.13 | 10.125 | 257.18 | 9.83 | 249.7 |  |

PART NUMBER LEGEND

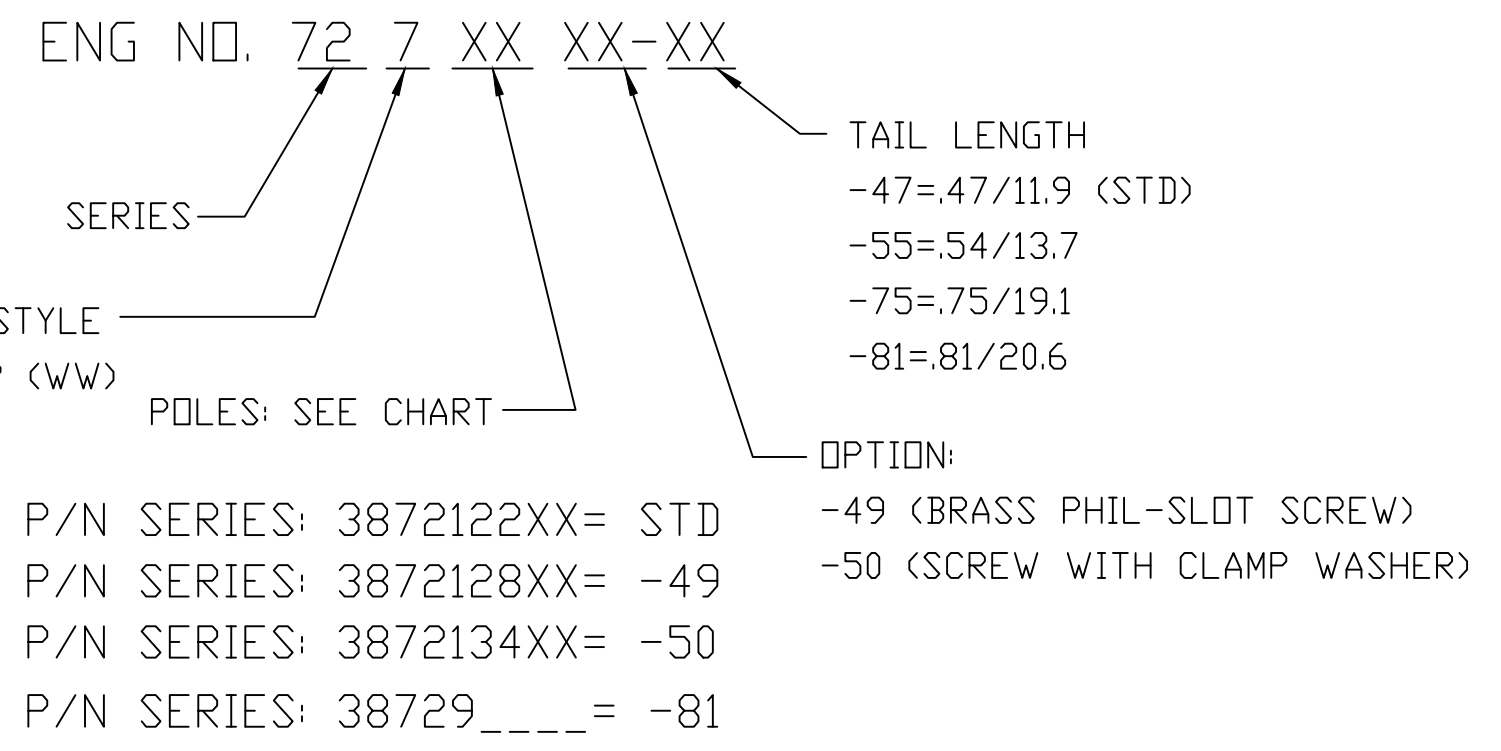

- NOTES:
1. MATERIAL: SEE TABLE
  2. ASSEMBLY MUST MEET BEAU WORKMANSHIP STANDARD ES-19900-059
  3. PRODUCT SPECIFICATION: PS-38710-001
  4. SEE SAP BOM FOR COMPONENT PART NUMBERS
  5. "XX" REFERS TO THE QUANTITY OF CIRCUITS

REF. THIS DRAWING SUPERSEDES E-78721-003 REV-B

|      |     |                                     |              |                 |
|------|-----|-------------------------------------|--------------|-----------------|
| 6    | XX  | #6-32 PH/SLOTTED SCREW (OPTION -50) | 380010099    | 2504-9201-C220  |
| 5    | XX  | #6-32 PH/SLOTTED SCREW (OPTION -49) | 380010058    | 1804-9101-A120  |
| 4    | XX  | #6-32 PH/SLOTTED SCREW (STD)        | 380010092    | 2504-9101-C220  |
| 3    | 2   | MOUNTING PLATE                      | 380021308    | 7204-7201-A120  |
| 2    | XX  | TERMINAL                            | 380021279    | 7204-3411-A260  |
| 1    | 1   | BARRIER TERMINAL STRIP              | 38728_       | 7200-XX02-V000  |
| ITEM | QTY | DESCRIPTION                         | MATERIAL NO. | ENGINEERING NO. |

RELEASED  
 EC NO: IFC2015-0118  
 DRWN: RSTONE 2014/07/18  
 CHKD: BARDEN 2014/07/23  
 APPR: JFMURPHY 2014/08/02

QUALITY SYMBOL  
 ▽=0  
 ▽=0

DESCRIPTION  
 A

GENERAL TOLERANCES (UNLESS SPECIFIED)

|          | mm    | INCH  |
|----------|-------|-------|
| 4 PLACES | ±---  | ±---  |
| 3 PLACES | ±---  | ±.005 |
| 2 PLACES | ±0.13 | ±.01  |
| 1 PLACE  | ±0.3  | ±---  |

ANGULAR ±---°

DRAFT WHERE APPLICABLE MUST REMAIN WITHIN DIMENSIONS

DIMENSION STYLE IN/MM

SCALE ---

DESIGN UNITS INCH

THIRD ANGLE PROJECTION

DRAWN BY RSTONE DATE 2014/07/18

CHECKED BY DATE

APPROVED BY JFMURPHY DATE 2014/08/02

MATERIAL NO. SEE PART LEGEND

DOCUMENT NO. E-38721-010

SHEET NO. 1 OF 1

THIS DRAWING CONTAINS INFORMATION THAT IS PROPRIETARY TO MOLEX INCORPORATED AND SHOULD NOT BE USED WITHOUT WRITTEN PERMISSION

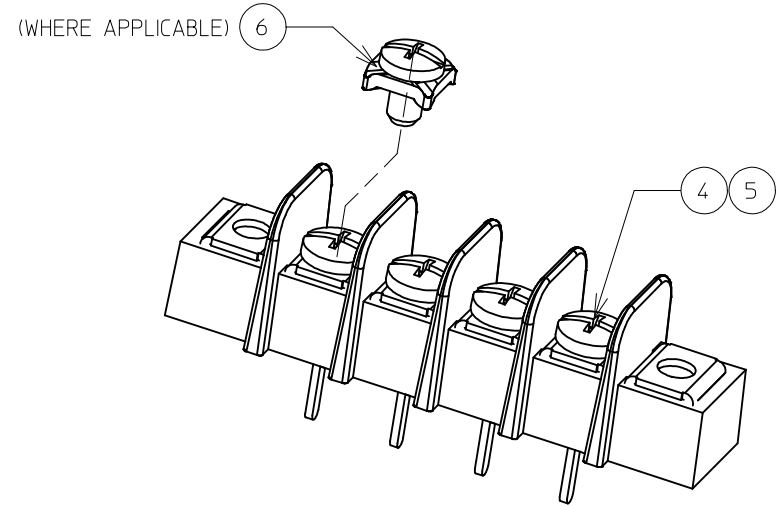
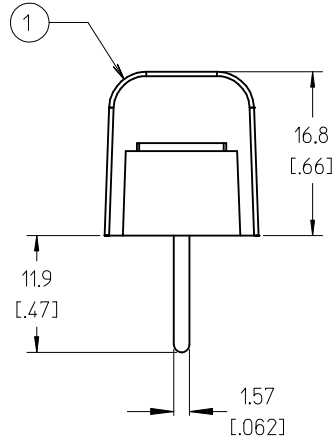
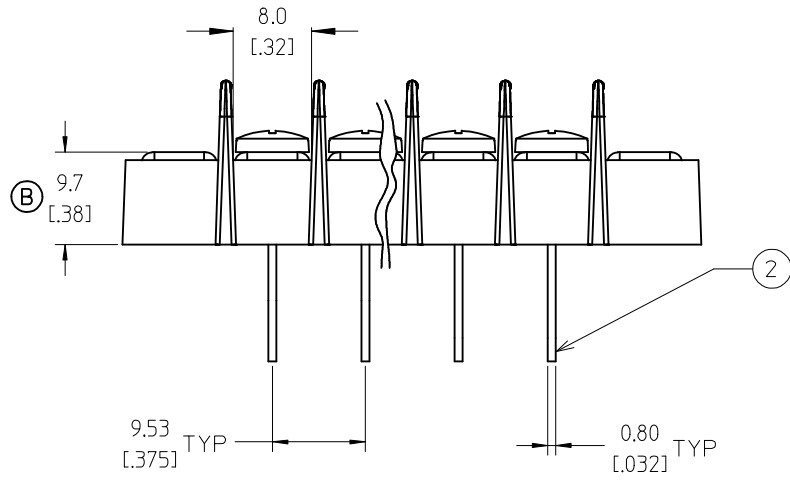
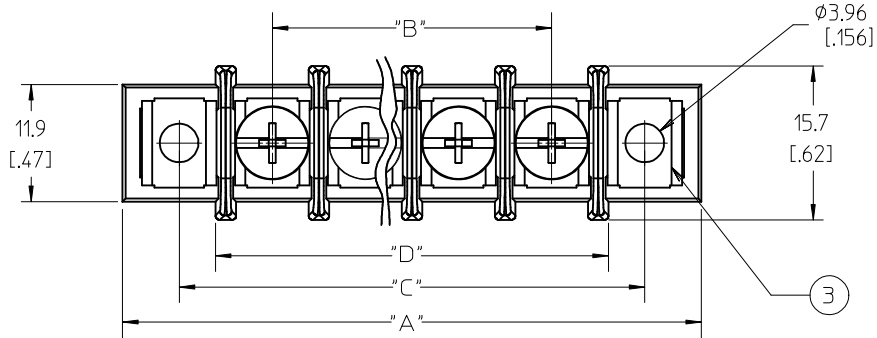

NOTES:

1. MATERIAL: SEE TABLE
2. FINISHES: SEE TABLE
3. PRODUCT SPECIFICATION: NOT REQUIRED
4. PACKAGING: NOT REQUIRED
5. MATES WITH: NONE
6. \*XX\* REFERS TO THE QUANTITY OF CIRCUITS.
7. ALL COMPONENTS ARE ROHS COMPLIANT.

| ITEM | QTY | DESCRIPTION                         | MATERIAL | FINISH             |
|------|-----|-------------------------------------|----------|--------------------|
| 6    | XX  | #6-32 PH/SLOTTED SCREW (OPTION -50) | STEEL    | ZN, CLEAR CHROMATE |
| 5    | XX  | #6-32 PH/SLOTTED SCREW (OPTION -49) | BRASS    | NICKEL PLATE       |
| 4    | XX  | #6-32 PH/SLOTTED SCREW (STD)        | STEEL    | ZN, CLEAR CHROMATE |
| 3    | 2   | MOUNTING PLATE                      | BRASS    | NICKEL PLATE       |
| 2    | XX  | TERMINAL                            | BRASS    | TIN PLATE          |
| 1    | 1   | BARRIER TERMINAL STRIP              | PBT      | BLACK              |

|   |
|---|
| UPDATE TERM. HEIGHT DIM.<br>EC NO: WNA2009-0445<br>DRWN: JENC INAS 2009/07/01<br>CHKD: CYORK 2009/07/02<br>APPR: JMACNE IL 2009/07/02 |
|---|

|                                |
|--------------------------------|
| QUALITY SYMBOLS<br>▽=0<br>▽7=0 |
|--------------------------------|

|  |
|--|
| GENERAL TOLERANCES (UNLESS SPECIFIED)                |
| 4 PLACES ± --- ± ---                                 |
| 3 PLACES ± --- ± .005                                |
| 2 PLACES ± 0.13 ± .01                                |
| 1 PLACE ± 0.3 ± ---                                  |
| ANGULAR ± 2 °  |
| DRAFT WHERE APPLICABLE MUST REMAIN WITHIN DIMENSIONS |

|  |
|--|
| DIMENSION STYLE<br>MM/IN               |
| DRAWN BY DATE<br>C. YORK 2006/03/24    |
| CHECKED BY DATE<br>RDEROSS 2006/03/24  |
| APPROVED BY DATE<br>RDEROSS 2006/03/24 |
| MATERIAL NO.                           |
| SEE CHART                              |

|  |                      |                        |
|--|----------------------|------------------------|
| SCALE<br>2:1   | DESIGN UNITS<br>INCH | THIRD ANGLE PROJECTION |
| TITLE<br>SR BTS, WW, ASSY<br>9.53 MM [0.375] CENTERS |                      |                        |
| MOLEX INCORPORATED                                   |                      |                        |
| DOCUMENT NO.<br>SD-38721-003                         | SHEET NO.<br>1 OF 2  |                        |

| NUMBER OF CIRCUITS "XX" | DIM. "A" |         | DIM. "B" |         | DIM. "C" |         | DIM. "D" |        |
|-------------------------|----------|---------|----------|---------|----------|---------|----------|--------|
| 02                      | 40.1     | [1.58]  | 9.53     | [.375]  | 28.6     | [1.13]  | 21.1     | [.83]  |
| 03                      | 49.7     | [1.96]  | 19.05    | [.750]  | 38.1     | [1.50]  | 30.6     | [1.21] |
| 04                      | 59.2     | [2.33]  | 28.58    | [1.125] | 47.6     | [1.88]  | 40.1     | [1.58] |
| 05                      | 68.7     | [2.71]  | 38.10    | [1.500] | 57.2     | [2.25]  | 49.7     | [1.96] |
| 06                      | 78.2     | [3.08]  | 47.63    | [1.875] | 66.7     | [2.63]  | 59.2     | [2.33] |
| 07                      | 87.8     | [3.46]  | 57.15    | [2.250] | 76.2     | [3.00]  | 68.7     | [2.71] |
| 08                      | 97.3     | [3.83]  | 66.68    | [2.625] | 85.7     | [3.38]  | 78.2     | [3.08] |
| 09                      | 106.8    | [4.21]  | 76.20    | [3.000] | 95.3     | [3.75]  | 87.8     | [3.46] |
| 10                      | 116.3    | [4.58]  | 85.73    | [3.375] | 104.8    | [4.13]  | 97.3     | [3.83] |
| 11                      | 125.9    | [4.96]  | 95.25    | [3.750] | 114.3    | [4.50]  | 106.8    | [4.21] |
| 12                      | 135.4    | [5.33]  | 104.78   | [4.125] | 123.8    | [4.88]  | 116.3    | [4.58] |
| 13                      | 144.9    | [5.71]  | 114.30   | [4.500] | 133.4    | [5.25]  | 125.9    | [4.96] |
| 14                      | 154.4    | [6.08]  | 123.83   | [4.875] | 142.9    | [5.63]  | 135.4    | [5.33] |
| 15                      | 164.0    | [6.46]  | 133.35   | [5.250] | 152.4    | [6.00]  | 144.9    | [5.71] |
| 16                      | 173.5    | [6.83]  | 142.88   | [5.625] | 161.9    | [6.38]  | 154.4    | [6.08] |
| 17                      | 183.0    | [7.21]  | 152.40   | [6.000] | 171.5    | [6.75]  | 164.0    | [6.46] |
| 18                      | 192.5    | [7.58]  | 161.93   | [6.375] | 181.0    | [7.13]  | 173.5    | [7.21] |
| 19                      | 202.1    | [7.96]  | 171.45   | [6.750] | 190.5    | [7.50]  | 192.5    | [7.58] |
| 20                      | 211.6    | [8.33]  | 180.98   | [7.125] | 200.0    | [7.88]  | 202.1    | [7.96] |
| 21                      | 221.1    | [8.71]  | 190.50   | [7.500] | 209.6    | [8.25]  | 211.6    | [8.33] |
| 22                      | 230.6    | [9.08]  | 200.03   | [7.875] | 219.1    | [8.63]  | 221.1    | [8.71] |
| 23                      | 240.2    | [9.46]  | 209.55   | [8.250] | 228.6    | [9.00]  | 230.6    | [9.08] |
| 24                      | 249.7    | [9.83]  | 219.08   | [8.625] | 238.1    | [9.38]  | 230.6    | [9.08] |
| 25                      | 259.2    | [10.21] | 228.60   | [9.000] | 247.7    | [9.75]  | 240.2    | [9.46] |
| 26                      | 268.7    | [10.58] | 238.13   | [9.375] | 257.2    | [10.13] | 249.7    | [9.83] |

| MATERIAL NO. (OPTION -50) | MATERIAL NO. (OPTION -49) | MATERIAL NO. (STANDARD) | NUMBER OF CIRCUITS "XX" |
|---------------------------|---------------------------|-------------------------|-------------------------|
| 38721-3402                | 38721-2802                | 38721-2202              | 02                      |
| 38721-3403                | 38721-2803                | 38721-2203              | 03                      |
| 38721-3404                | 38721-2804                | 38721-2204              | 04                      |
| 38721-3405                | 38721-2805                | 38721-2205              | 05                      |
| 38721-3406                | 38721-2806                | 38721-2206              | 06                      |
| 38721-3407                | 38721-2807                | 38721-2207              | 07                      |
| 38721-3408                | 38721-2808                | 38721-2208              | 08                      |
| 38721-3409                | 38721-2809                | 38721-2209              | 09                      |
| 38721-3410                | 38721-2810                | 38721-2210              | 10                      |
| 38721-3411                | 38721-2811                | 38721-2211              | 11                      |
| 38721-3412                | 38721-2812                | 38721-2212              | 12                      |
| 38721-3413                | 38721-2813                | 38721-2213              | 13                      |
| 38721-3414                | 38721-2814                | 38721-2214              | 14                      |
| 38721-3415                | 38721-2815                | 38721-2215              | 15                      |
| 38721-3416                | 38721-2816                | 38721-2216              | 16                      |
| 38721-3417                | 38721-2817                | 38721-2217              | 17                      |
| 38721-3418                | 38721-2818                | 38721-2218              | 18                      |
| 38721-3419                | 38721-2819                | 38721-2219              | 19                      |
| 38721-3420                | 38721-2820                | 38721-2220              | 20                      |
| 38721-3421                | 38721-2821                | 38721-2221              | 21                      |
| 38721-3422                | 38721-2822                | 38721-2222              | 22                      |
| 38721-3423                | 38721-2823                | 38721-2223              | 23                      |
| 38721-3424                | 38721-2824                | 38721-2224              | 24                      |
| 38721-3425                | 38721-2825                | 38721-2225              | 25                      |
| 38721-3426                | 38721-2826                | 38721-2226              | 26                      |

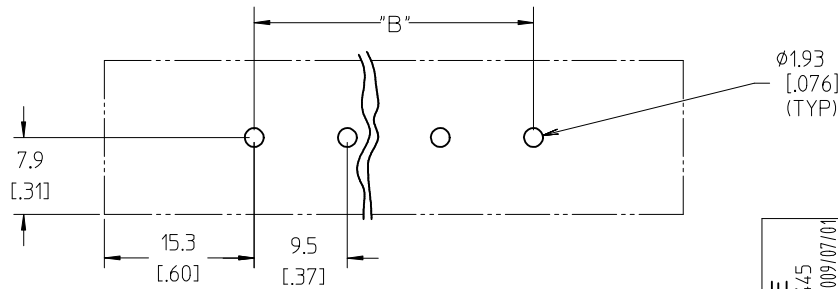

| <b>SEE SHEET ONE</b><br>EC NO: WNA2009-0445<br>DRWN: JENC INAS 2009/07/01<br>CHKD: CYORK 2009/07/02<br>APPR: JMACNE IL 2009/07/02 | QUALITY SYMBOLS<br>▽=0<br>▽=0 | GENERAL TOLERANCES (UNLESS SPECIFIED)<br><table border="1"> <tr><th colspan="2">mm</th><th colspan="2">INCH</th></tr> <tr><td>4 PLACES</td><td>± ---</td><td>± ---</td><td></td></tr> <tr><td>3 PLACES</td><td>± ---</td><td>± .005</td><td></td></tr> <tr><td>2 PLACES</td><td>± 0.13</td><td>± .01</td><td></td></tr> <tr><td>1 PLACE</td><td>± 0.3</td><td>± ---</td><td></td></tr> </table> | mm                               |                    | INCH   |                            | 4 PLACES | ± --- | ± --- |  | 3 PLACES | ± --- | ± .005 |  | 2 PLACES | ± 0.13 | ± .01 |  | 1 PLACE | ± 0.3 | ± --- |  | DIMENSION STYLE<br><b>MM/IN</b> | SCALE<br><b>2:1</b> | DESIGN UNITS<br><b>INCH</b> | THIRD ANGLE PROJECTION |
|---|-------------------------------|---|----------------------------------|--------------------|--|----------------------------|----------|-------|-------|--|----------|-------|--------|--|----------|--------|-------|--|---------|-------|-------|--|---------------------------------|---------------------|-----------------------------|------------------------|
|   | mm                            |   | INCH                             |                    |  |                            |          |       |       |  |          |       |        |  |          |        |       |  |         |       |       |  |                                 |                     |                             |                        |
|   | 4 PLACES                      | ± ---   | ± ---                            |                    |  |                            |          |       |       |  |          |       |        |  |          |        |       |  |         |       |       |  |                                 |                     |                             |                        |
|   | 3 PLACES                      | ± ---   | ± .005                           |                    |  |                            |          |       |       |  |          |       |        |  |          |        |       |  |         |       |       |  |                                 |                     |                             |                        |
| 2 PLACES  | ± 0.13                        | ± .01   |                                  |                    |  |                            |          |       |       |  |          |       |        |  |          |        |       |  |         |       |       |  |                                 |                     |                             |                        |
| 1 PLACE   | ± 0.3                         | ± ---   |                                  |                    |  |                            |          |       |       |  |          |       |        |  |          |        |       |  |         |       |       |  |                                 |                     |                             |                        |
| DRAFT WHERE APPLICABLE<br>MUST REMAIN<br>WITHIN DIMENSIONS  | DRAWN BY<br>C. YORK           | DATE<br>2006/03/24  | CHECKED BY<br>RDEROSS            | DATE<br>2006/03/24 | TITLE<br><b>SR BTS, WW, ASSY<br/>                 9.53 MM [.375] CENTERS</b> |                            |          |       |       |  |          |       |        |  |          |        |       |  |         |       |       |  |                                 |                     |                             |                        |
|   | APPROVED BY<br>RDEROSS        | DATE<br>2006/03/24  | MATERIAL NO.<br><b>SEE CHART</b> |                    | DOCUMENT NO.<br><b>SD-38721-003</b>  | SHEET NO.<br><b>2 OF 2</b> |          |       |       |  |          |       |        |  |          |        |       |  |         |       |       |  |                                 |                     |                             |                        |
|   | SIZE<br><b>B</b>              | THIS DRAWING CONTAINS INFORMATION THAT IS PROPRIETARY TO MOLEX INCORPORATED AND SHOULD NOT BE USED WITHOUT WRITTEN PERMISSION   |                                  |                    |  |                            |          |       |       |  |          |       |        |  |          |        |       |  |         |       |       |  |                                 |                     |                             |                        |

PART NUMBER DATA

| CIRCUITS | A IN  | mm    | B IN  | mm     | C IN   | mm     | D IN | mm    |
|----------|-------|-------|-------|--------|--------|--------|------|-------|
| 2        | 1.58  | 40.2  | .375  | 9.52   | 1.125  | 28.58  | .83  | 21.1  |
| 3        | 1.96  | 49.7  | .750  | 19.05  | 1.500  | 38.10  | 1.21 | 30.7  |
| 4        | 2.33  | 59.2  | 1.125 | 28.58  | 1.875  | 47.63  | 1.58 | 40.2  |
| 5        | 2.71  | 68.7  | 1.500 | 38.10  | 2.250  | 57.15  | 1.96 | 49.7  |
| 6        | 3.08  | 78.3  | 1.875 | 47.63  | 2.625  | 66.68  | 2.33 | 59.2  |
| 7        | 3.46  | 87.8  | 2.250 | 57.15  | 3.000  | 76.20  | 2.71 | 68.8  |
| 8        | 3.83  | 97.3  | 2.625 | 66.68  | 3.375  | 85.73  | 3.08 | 78.3  |
| 9        | 4.21  | 106.8 | 3.000 | 76.20  | 3.750  | 95.25  | 3.46 | 87.8  |
| 10       | 4.58  | 116.4 | 3.375 | 85.73  | 4.125  | 104.78 | 3.83 | 97.3  |
| 11       | 4.96  | 125.9 | 3.750 | 95.25  | 4.500  | 114.30 | 4.21 | 106.9 |
| 12       | 5.33  | 135.4 | 4.125 | 104.78 | 4.875  | 123.83 | 4.58 | 116.4 |
| 13       | 5.71  | 144.9 | 4.500 | 114.30 | 5.250  | 133.35 | 4.96 | 125.9 |
| 14       | 6.08  | 154.5 | 4.875 | 123.83 | 5.625  | 142.88 | 5.33 | 135.4 |
| 15       | 6.46  | 164.0 | 5.250 | 133.35 | 6.000  | 152.40 | 5.71 | 145.0 |
| 16       | 6.83  | 173.5 | 5.625 | 142.88 | 6.375  | 161.93 | 6.08 | 154.5 |
| 17       | 7.21  | 183.0 | 6.000 | 152.40 | 6.750  | 171.45 | 6.46 | 164.0 |
| 18       | 7.58  | 192.6 | 6.375 | 161.93 | 7.125  | 180.98 | 6.83 | 173.5 |
| 19       | 7.96  | 202.1 | 6.750 | 171.45 | 7.500  | 190.50 | 7.21 | 183.1 |
| 20       | 8.33  | 211.6 | 7.125 | 180.98 | 7.875  | 200.03 | 7.58 | 192.6 |
| 21       | 8.71  | 221.1 | 7.500 | 190.50 | 8.250  | 209.55 | 7.96 | 202.1 |
| 22       | 9.08  | 230.7 | 7.875 | 200.03 | 8.625  | 219.08 | 8.33 | 211.6 |
| 23       | 9.46  | 240.2 | 8.250 | 209.55 | 9.000  | 228.60 | 8.71 | 221.2 |
| 24       | 9.83  | 249.7 | 8.625 | 219.08 | 9.375  | 238.13 | 9.08 | 230.7 |
| 25       | 10.21 | 259.2 | 9.000 | 228.60 | 9.750  | 247.65 | 9.46 | 240.2 |
| 26       | 10.58 | 268.8 | 9.375 | 238.13 | 10.125 | 257.18 | 9.83 | 249.7 |

ISO VIEW  
4 CIRCUIT SHOWN

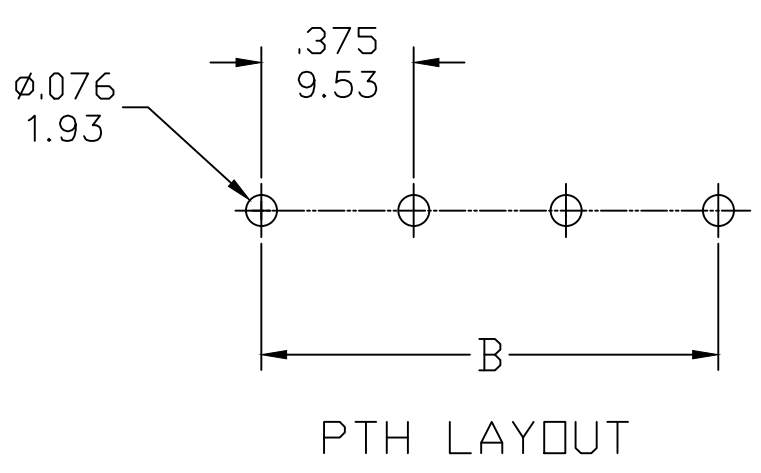
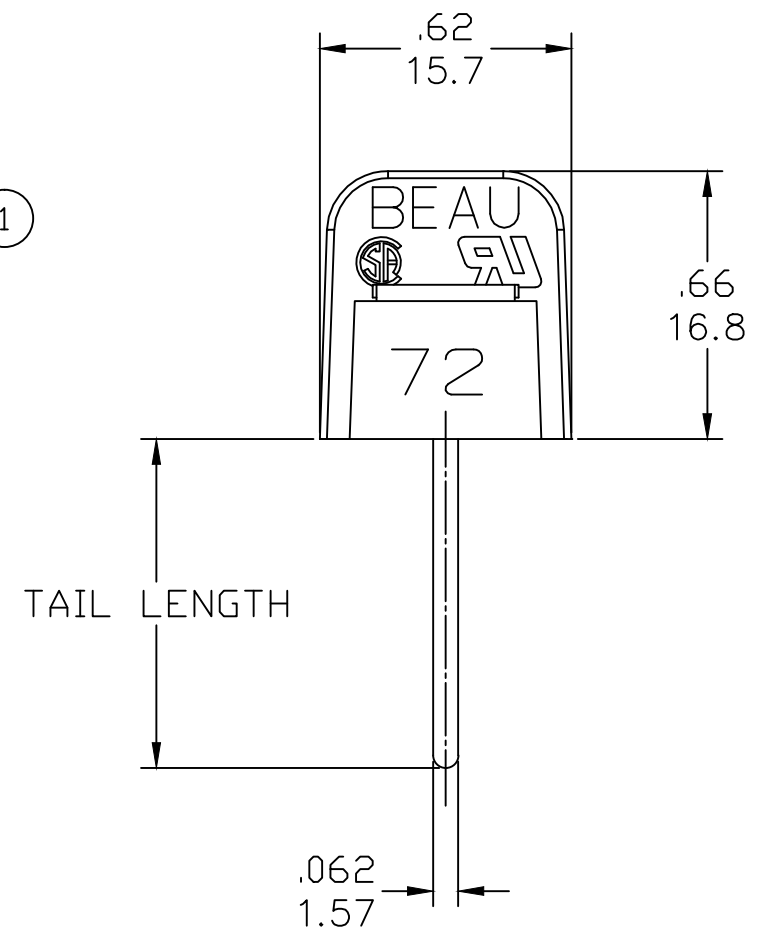
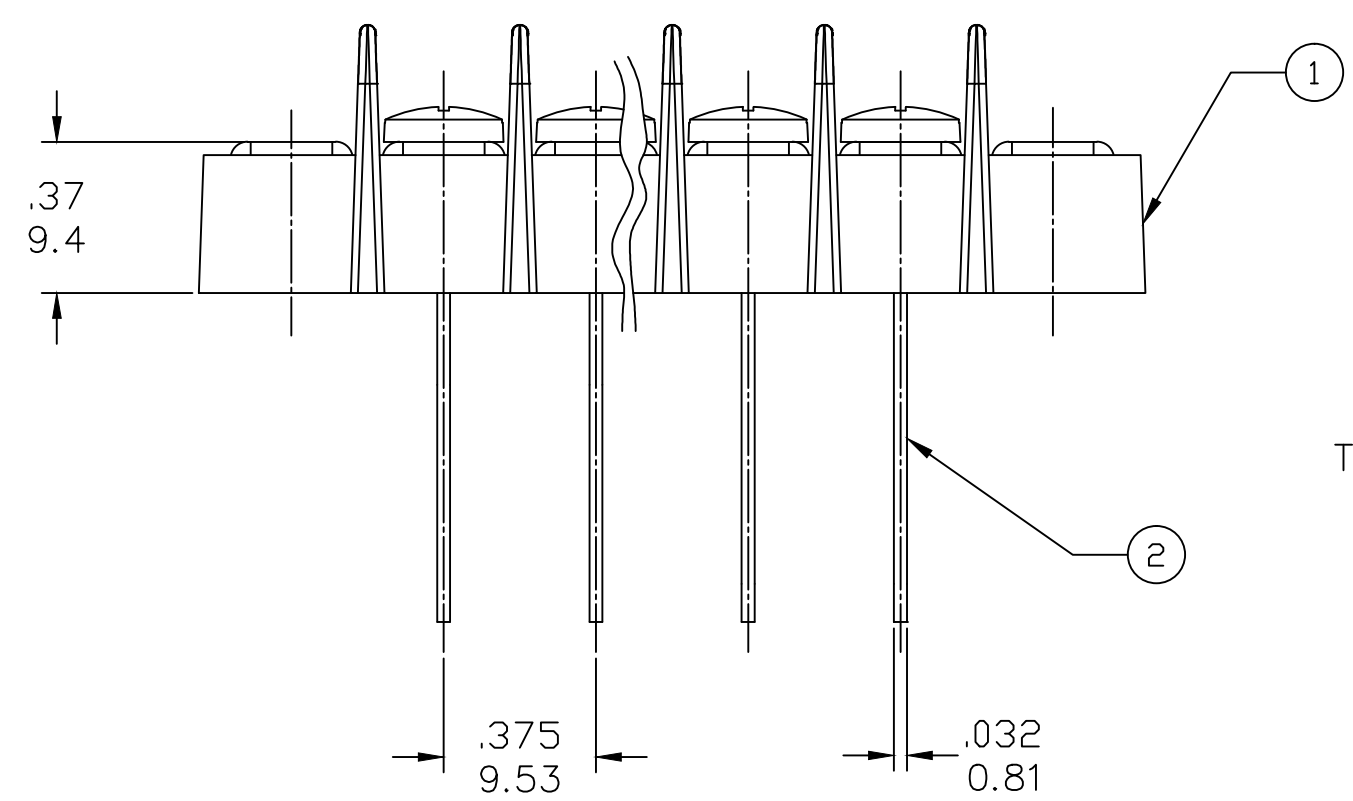
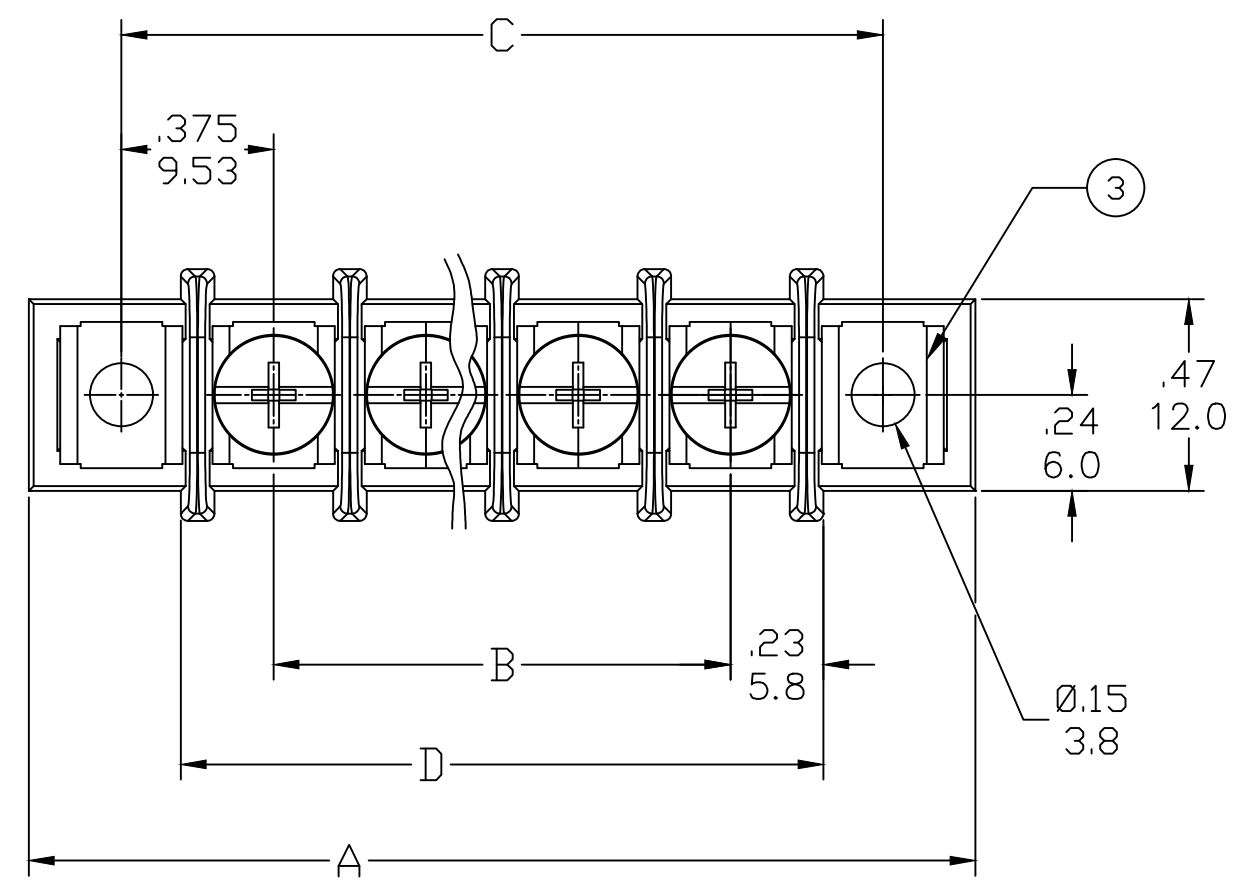
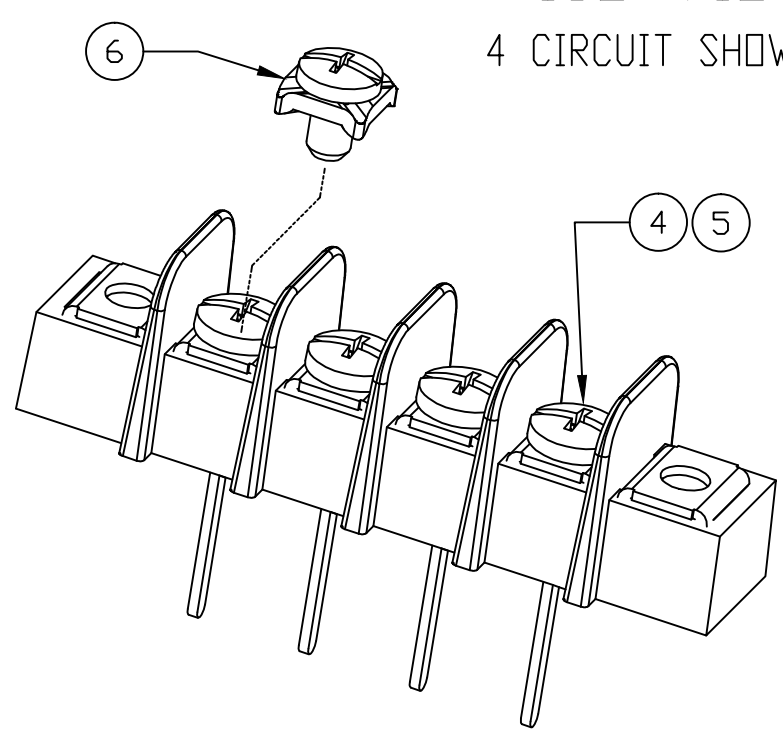

- NOTES:
- MATERIAL: SEE TABLE
  - FINISHES: SEE TABLE
  - PRODUCT SPECIFICATION: PS-38710-001
  - "XX" REFERS TO THE QUANTITY OF CIRCUITS
  - DIMS SHOWN ARE FOR REFERENCE ONLY

PART NUMBER LEGEND

ENG NO. 72 7 XX XX-XX

SERIES

TAIL LENGTH  
-47=.47/11.9 (STD)  
-55=.54/13.7  
-75=.75/19.1  
-81=.81/20.6

OPTION:  
-49 (BRASS PHIL-SLOT SCREW)  
-50 (SCREW WITH CLAMP WASHER)

TERMINAL STYLE  
WIRE WRAP (WW)

POLES: SEE CHART

SAP P/N SERIES: 3872122XX= STD  
SAP P/N SERIES: 3872128XX= -49  
SAP P/N SERIES: 3872134XX= -50  
SAP P/N SERIES: 38729\_\_\_= -81

REF. THIS DRAWING SUPERSEDES SD-78721-003 REV-B

| ITEM | QTY | DESCRIPTION                         | MATERIAL | FINISH             |
|------|-----|-------------------------------------|----------|--------------------|
| 6    | XX  | #6-32 PH/SLOTTED SCREW (OPTION -50) | STEEL    | ZN, CLEAR CHROMATE |
| 5    | XX  | #6-32 PH/SLOTTED SCREW (OPTION -49) | BRASS    | NICKEL PLATE       |
| 4    | XX  | #6-32 PH/SLOTTED SCREW (STD)        | STEEL    | ZN, CLEAR CHROMATE |
| 3    | 2   | MOUNTING PLATE                      | BRASS    | NICKEL PLATE       |
| 2    | XX  | TERMINAL                            | BRASS    | TIN PLATE          |
| 1    | 1   | BARRIER TERMINAL STRIP              | PBT      | BLACK              |

RELEASED  
EC NO: ICG2015-0118  
DRWN: RSTONE 2014/07/17  
CHKD: BARDEN 2014/07/23  
APPR: JFMURPHY 2014/08/02

DESCRIPTION

QUALITY SYMBOL  
▽=0  
▽C=0

GENERAL TOLERANCES (UNLESS SPECIFIED)

|          | mm    | INCH  |
|----------|-------|-------|
| 4 PLACES | ±---  | ±---  |
| 3 PLACES | ±---  | ±.005 |
| 2 PLACES | ±0.13 | ±.01  |
| 1 PLACE  | ±0.3  | ±---  |

ANGULAR ±---°

DRAFT WHERE APPLICABLE MUST REMAIN WITHIN DIMENSIONS

DIMENSION STYLE IN/MM

SCALE ---

DESIGN UNITS INCH

THIRD ANGLE PROJECTION

DRAWN BY RSTONE DATE 2014/07/17

CHECKED BY BARDEN DATE ---

APPROVED BY JFMURPHY DATE 2014/08/02

MATERIAL NO. SEE PART LEGEND

DOCUMENT NO. SD-38721-010

SHEET NO. 1 OF 1

THIS DRAWING CONTAINS INFORMATION THAT IS PROPRIETARY TO MOLEX INCORPORATED AND SHOULD NOT BE USED WITHOUT WRITTEN PERMISSION