



# SPECIFICATION FOR DYNAMIC Speaker

TOTAL PAGE 08 [www.bestargroups.com](http://www.bestargroups.com) ROHS

## Preliminary Specification For The Acoustic Characteristics of Dynamic Speaker

Customer		Model Name	BLS2828-12-08H11 LF
Customer P/N		Product No.	124911
Date	18 Jun. 13	Issue No.	BS/TES01.1249A
Page	01 of 08	Issue Date	2013/6/18

### Approval:

1. Technical Terms
2. Drawing
3. Reliability Test
4. Packing
5. History Change Record

Drawn by	Checked by	Approved by	Customer approved

### **BESTAR ACOUSTICS CO., LTD**

No.199 HuangHe West Road, New district, ChangZhou, JiangSu Province, P.R.China

**Tel:** +86 519 88222567 **Fax:** +86 519 88222551

**E-mail:** [wu@be-star.com](mailto:wu@be-star.com) **<http://www.bestargroups.com>**

# BLS2828-12-08H11 LF

## 1. Technical Terms

No.	Item	Specification
1.	Dimension	28X28X11(mm)
2.	AC Impedance(at 1kHz)	$8 \pm 15\% \Omega$
3.	Rated Input Power	2.0W
4.	Maximum Input Power	2.5W
5.	Resonance Frequency	$400 \pm 20\% \text{Hz}$
6.	Frequency Response	$F_0 \sim 20\text{KHz}$
7.	Output SPL	$84 \pm 3\text{dB}$ (0.1W /0.1m) at 0.8~1.5KHz average
8.	Distortion	$\leq 5\%$ ( at 1kHz,2.0W )
9.	Buzzes & Rattles	must be normal at 2.83Vrms (sine wave)
10.	Operating Temperature	$-30 \sim +70^\circ\text{C}$
11.	Storage Temperature	$-40 \sim +85^\circ\text{C}$
12.	Weight	$\sim 11.8\text{g}$

## 1.2 Test Method

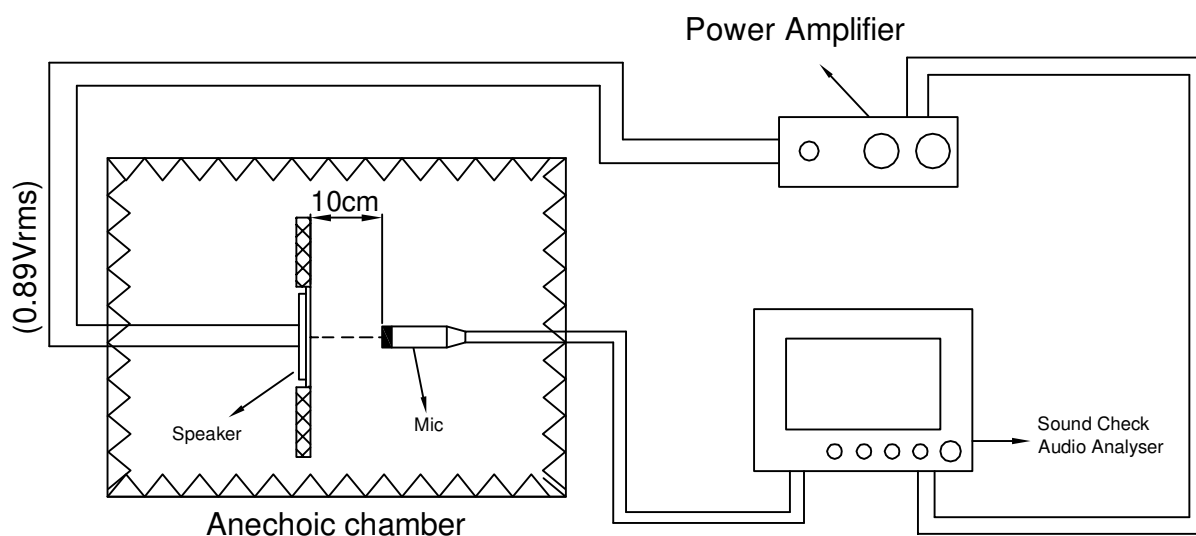

				Date:	2013/6/18	BLS2828-12-08H11 LF	
				Drawn by:	张小红		
A	2013/6/18	张小红		Checked by:	汪凤声	Speaker	
Rev.	Date	Drawn	Note	Approved by:	王平		
BESTAR ACOUSTICS CO.,LTD				www.bestargroups.com wu@be-star.com		DRG NO:BS/TES01.1249A	Page:02 of 08

This print and information there in are proprietary to BeStar Acoustics Co., Ltd. and shall not be used in whole or in part without its written content

# BLS2828-12-08H11 LF

1.3 Frequency Response Curve (only for reference)

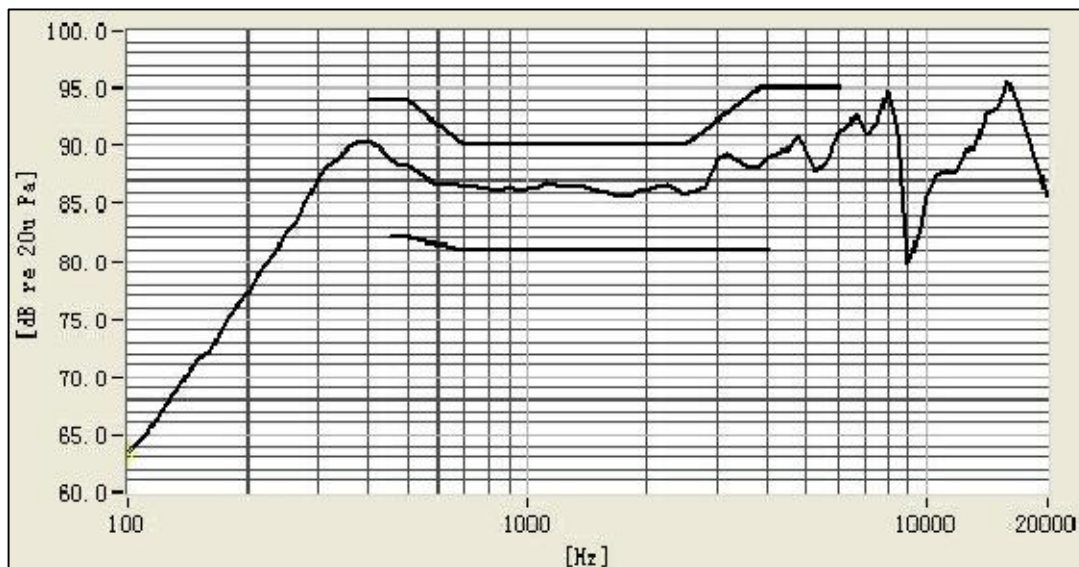

Frequency (Hz)

1.4 Total Harmonic Distortion Curve (only for reference)

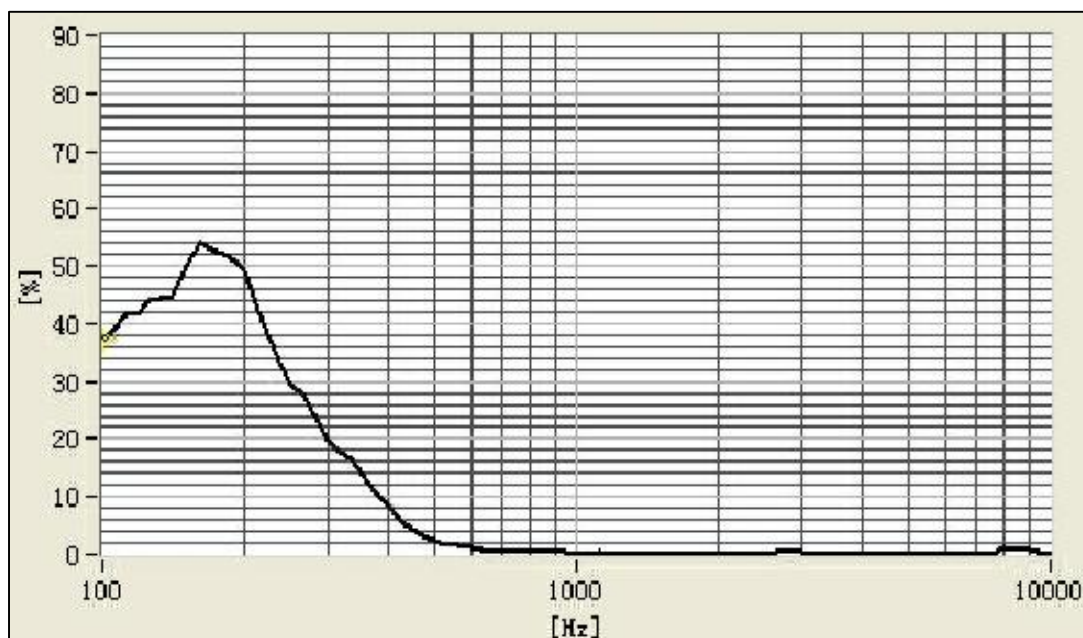

This print and information there in are proprietary to BeStar Acoustics Co., Ltd. and shall not be used in whole or in part without its written content.

				Date:	2013/6/18	BLS2828-12-08H11 LF	
				Drawn by:	张小红		
A	2013/6/18	张小红		Checked by:	汪凤声	Speaker	
Rev.	Date	Drawn	Note	Approved by:	王平		
BESTAR ACOUSTICS CO.,LTD				www.bestargroups.com wu@be-star.com		DRG NO:BS/TES01.1249A	Page:03 of 08

# BLS2828-12-08H11 LF

1.5 Impedance Response Curve (only for reference)

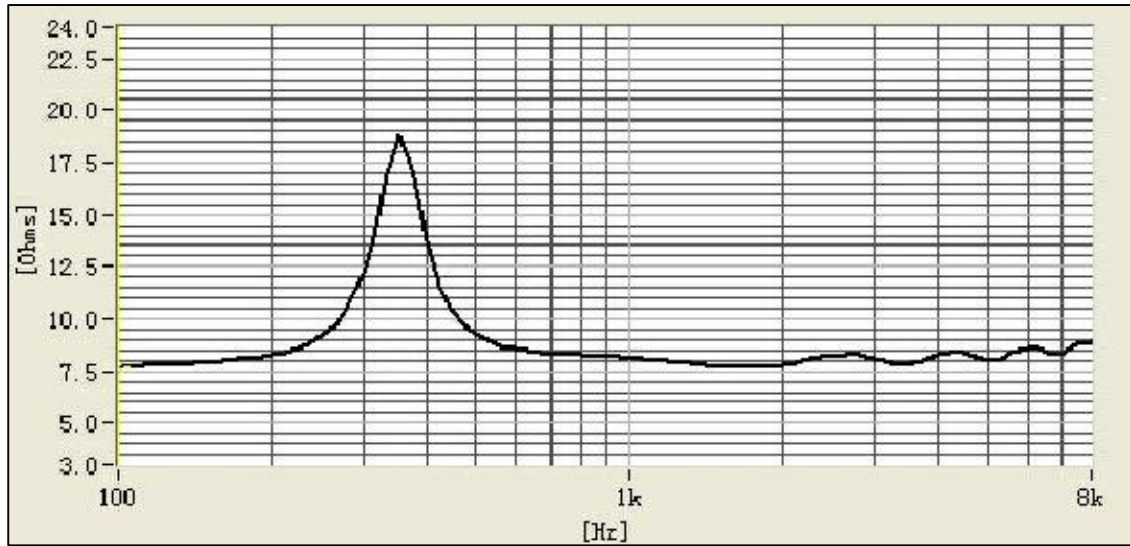

1.6 RUB Response Curve (only for reference)

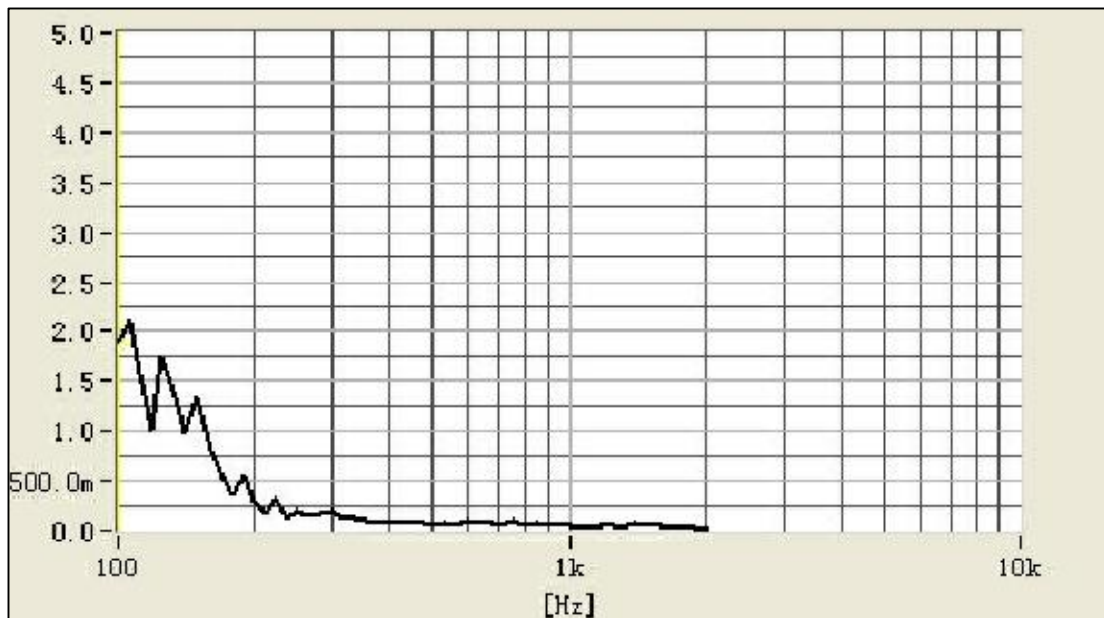

This print and information there in are proprietary to BeStar Acoustics Co., Ltd. and shall not be used in whole or in part without its written consent.

			Date:	2013/6/18	BLS2828-12-08H11 LF
			Drawn by:	张小红	
A	2013/6/18	张小红	Checked by:	汪凤声	Speaker
Rev.	Date	Drawn	Approved by:	王平	
BESTAR ACOUSTICS CO.,LTD			www.bestargroups.com wu@be-star.com		DRG NO:BS/TES01.1249A Page:04 of 08

# BLS2828-12-08H11 LF

## 2.Drawing

Unit:mm  
tolerance:±0.5

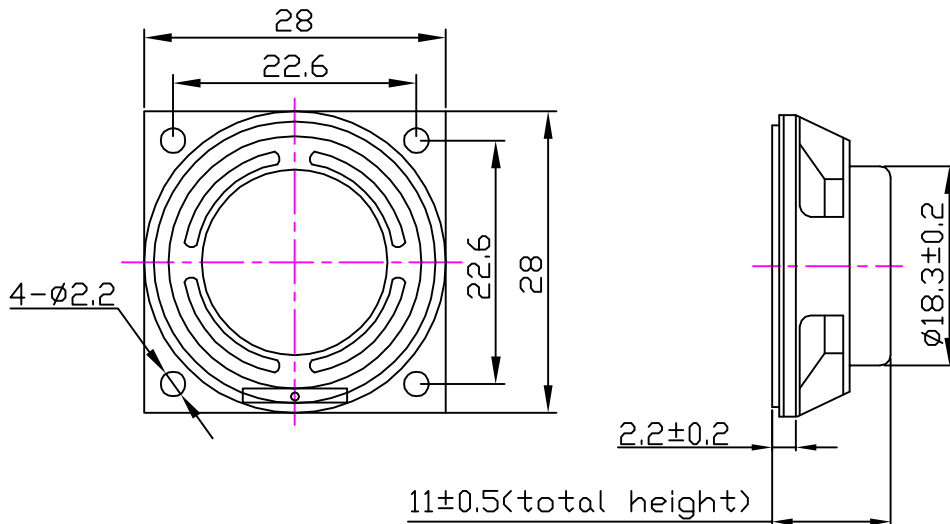

### ☆.T/S parameter

$F_s=312.1576\text{Hz}$	$V_{AS}=0.0216\text{L}$	$R_e=3.710\Omega$
$Q_{MS}=4.7069$	$Q_{ES}=3.2375$	$Q_{TS}=1.9181$
$B.L=0.7254\text{T.m}$	$\text{dB}_{SPL}=82.0961$	$S_D=0.0004\text{m}^2$
$C_{MS}=1.1102\text{mm/N}$	$M_{MS}=0.2341\text{g}$	$R_{MS}=0.0976\Omega_M$
$C_{AS}=1.55\text{E-}0010\text{m}^5/\text{N}$	$M_{AS}=1680.62\text{kg/m}^4$	$R_{AS}=700313\Omega_A$
$C_{MES}=444.9135\mu\text{F}$	$L_{CES}=0.5843\text{mH}$	$R_{ES}=5.3939\Omega$
$R_{AT}=1718481\Omega_A$	$R_{MT}=0.2394\Omega_M$	$M_{MD}=0.2301\text{g}$
$Z_{MIN}=4.0899\Omega$	$Z_{MAX}=9.1039\Omega$	$Z_{AVD}=4.5815\Omega$
$\eta_0=0.0195\%$	$L_{1\text{KHZ}}=0.0103\text{mH}$	$L_{10\text{KHZ}}=0.0327\text{mH}$

Date: 2013/6/18

Drawn by: 张小红

Checked by: 汪凤声

Approved by: 王平

BLS2828-12-08H11 LF

Speaker

BESTAR ACOUSTICS CO.,LTD

[www.bestargroups.com](http://www.bestargroups.com) [wu@be-star.com](mailto:wu@be-star.com)

DRG NO:BS/TES01.1249A

Page:05 of 08

# BLS2828-12-08H11 LF

## 3. Reliability Test

3.1 Load Test	
Power	2W ( sine wave)
Duration	96hrs
3.2 High Temperature Test	
Temperature	+85±3°C
Relative Humidity	20%-50%RH
Duration	16hrs
3.3 Low Temperature Test	
Temperature	-25±3 °C
Duration	16hrs
3.4 Damp Heat	
Temperature	40±3°C
Relative Humidity	90%-95%RH
Duration	16hrs
3.5 Temperature Cycle Test	
Cycle	4

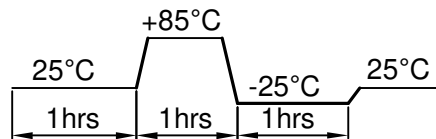

3.6 Drop Test	
Height	100cm (in state of packing)
Times	10 (Drop onto hardwood board)

**Notice:**

- All these tests above should be measured after leaving normal temperature for 2hrs.
- sensitivity difference at 1kHz shall be within ±3dB from initial value after test.

This print and information there in are proprietary to BeStar Acoustics Co., Ltd. and shall not be used in whole or in part without its written content

			Date:	2013/6/18	BLS2828-12-08H11 LF
			Drawn by:	张小红	
A	2013/6/18	张小红	Checked by:	汪凤声	Speaker
Rev.	Date	Drawn	Note	Approved by:	
BESTAR ACOUSTICS CO.,LTD				www.bestargroups.com wu@be-star.com	
				DRG NO:BS/TES01.1249A	Page:06 of 08

# BLS2828-12-08H11 LF

## 4. Packing

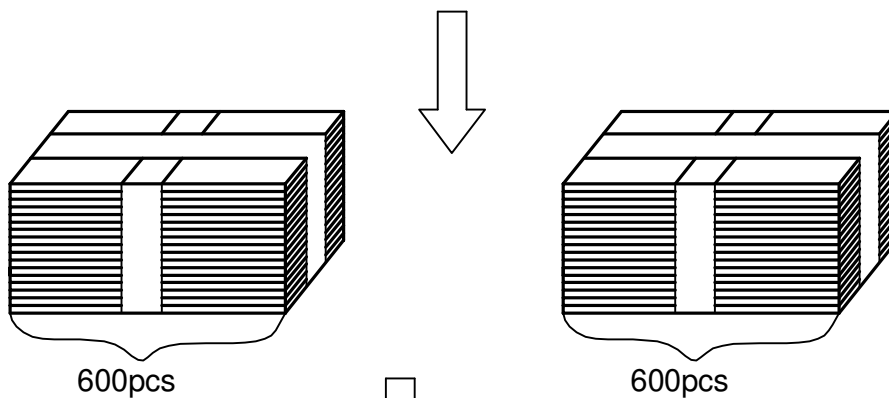
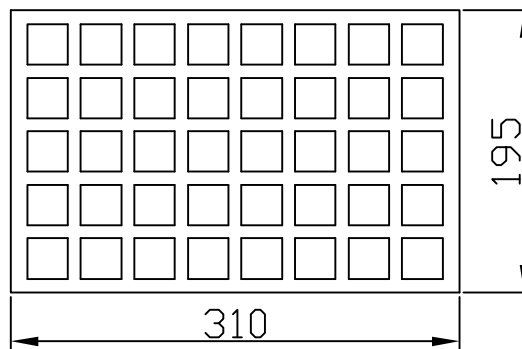

600 pcs

600 pcs

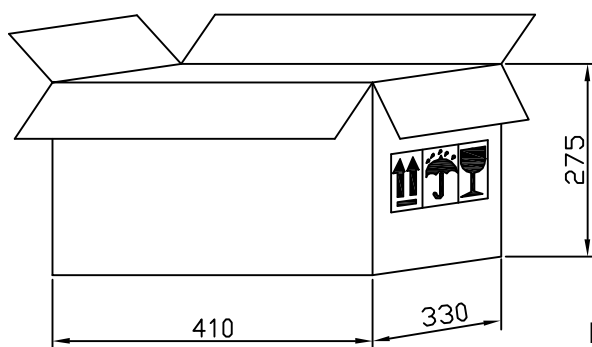

Remark:  
 40 pcs per tray  
 15 trays for unit, 2 units per carton  
 Total 1200pcs per carton  
 Size: 41×33×27.5(cm)

This print and information there in are proprietary to BeStar Acoustics Co., Ltd. and shall not be used in whole or in part without its written content

				Date:	2013/6/18	BLS2828-12-08H11 LF	
				Drawn by:	张小红		
A	2013/6/18	张小红		Checked by:	汪风声	Speaker	
Rev.	Date	Drawn	Note	Approved by:	王平		
BESTAR ACOUSTICS CO.,LTD				www.bestargroups.com wu@be-star.com		DRG NO:BS/TES01.1249A	Page:07 of 08

