

VICOR CONFIDENTIAL
 THIS DOCUMENT AND THE DATA DISCLOSED HEREIN OR
 HEREWITH IS NOT TO BE REPRODUCED, USED OR
 DISCLOSED IN WHOLE OR IN PART TO ANYONE WITHOUT
 THE PERMISSION OF VICOR CORP.

| REV. | DESCRIPTION | INTL | DATE | APVD |
|------|----------------------|------|----------|------|
| 1 | RELEASE PER E161031b | GCK | 11/22/16 | RH |

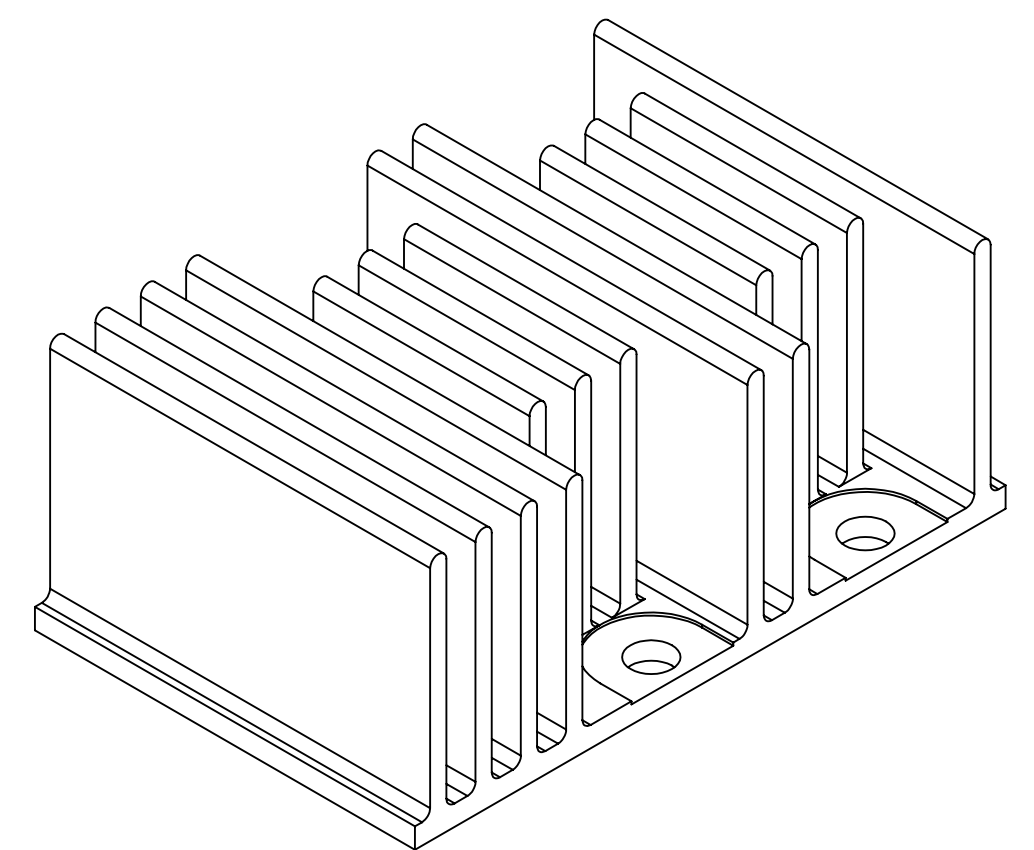
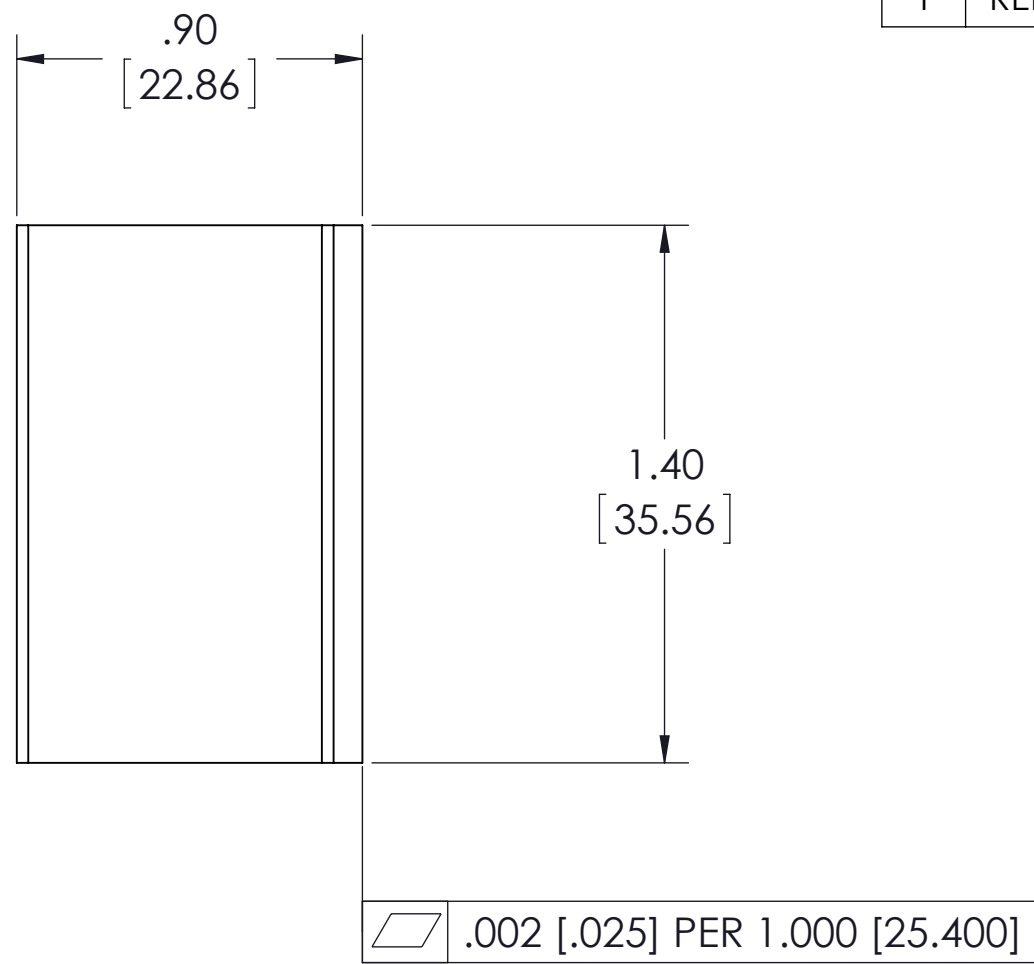
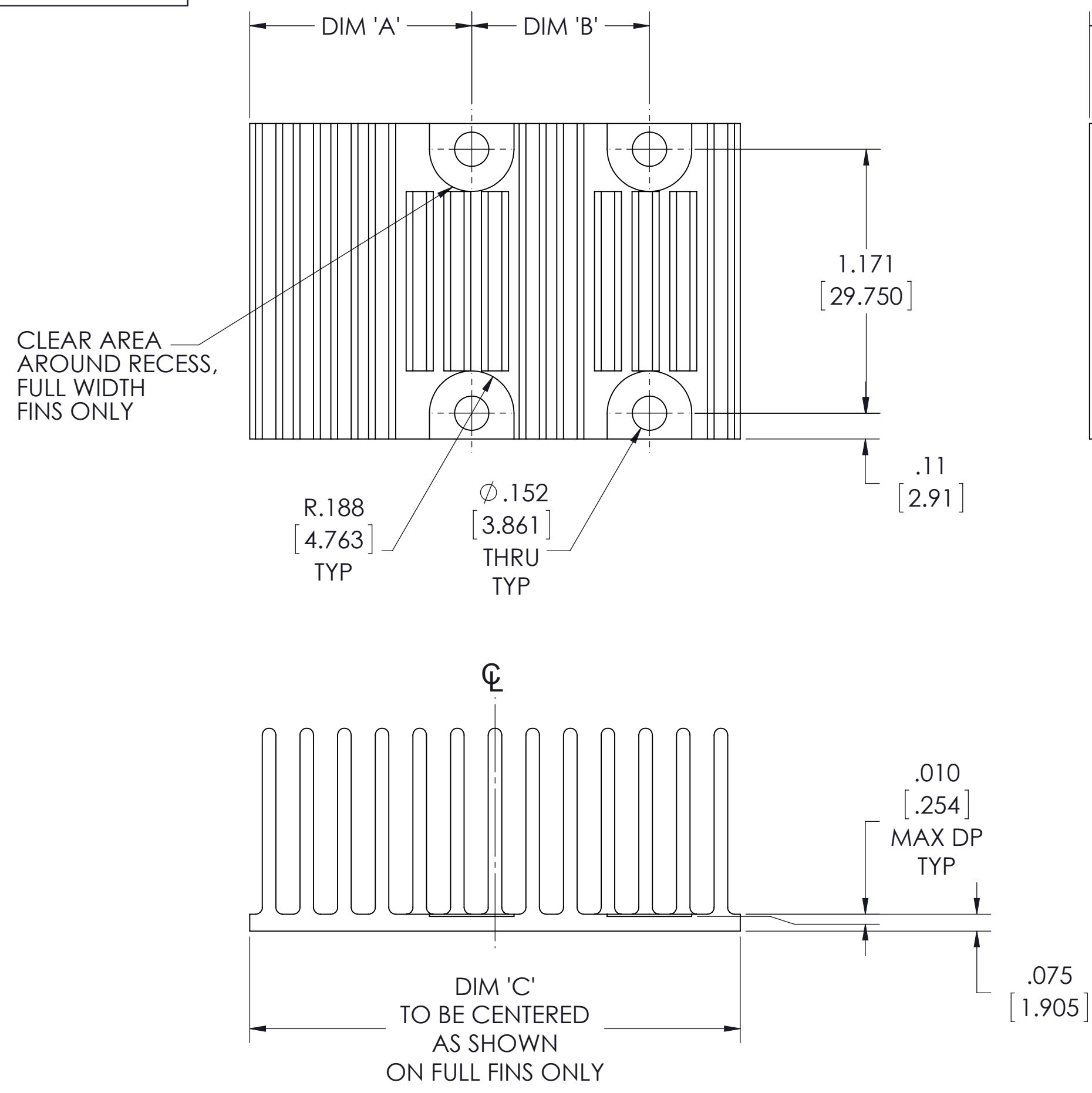

- NOTES:
- CLEAR FINISH, RoHS COMPLIANT PER CST-0001, LATEST REVISION PER
 A.) CHROMIUM FREE, OR
 B.) TRIVALENT CHROMIUM IN ACCORDANCE WITH MIL-DTL-5541, TYPE II, CLASS 1A OR 3. SEE CST-0003 FOR TYPES OF AVAILABLE FINISHES.
 - SEE CHART FOR BOM NUMBERS
 SEE BOMS FOR PARTS LIST.
 - MATERIAL: MAKE FROM AAVID EXTRUSION P/N 74765 OR EQUIVALENT (VICOR P/N 42596)
 - REMOVE ALL BURRS AND SHARP EDGES

| BOM NUMBER | PRODUCT | DIM 'A' | DIM 'B' | DIM 'C' |
|------------|-------------------------|--------------|----------------|---------------|
| 43808-01 | 2214 (0 STAGE) 2223 | 0.57 [14.55] | N/A | 1.23 [31.16] |
| 43808-02 | 2814 (1 STAGE) 2223 | 0.95 [24.22] | N/A | 1.60 [40.69] |
| 43808-03 | 2814 (0 STAGE) 3623 | 0.57 [14.55] | 0.789 [20.033] | 1.77 [45.04] |
| 43808-04 | 3414 (1 STAGE) 3623 | 0.98 [25.00] | 0.789 [20.033] | 2.18 [55.25] |
| 43808-05 | 3714 (1 STAGE) 4623 | 0.98 [25.00] | 1.150 [29.200] | 2.55 [64.65] |
| 43808-06 | 3814 (0 STAGE) 2361 | 0.39 [10.03] | 1.277 [32.430] | 2.56 [65.11] |
| 43808-07 | 3814 (0 STAGE) 2361 NBM | 0.39 [10.03] | 1.277 [32.430] | 2.56 [65.11] |
| 43808-08 | 4414 (1 STAGE) 2361 | 0.98 [25.00] | 1.277 [32.430] | 3.15 [80.07] |
| 43808-09 | 4414 (1 STAGE) 6123 | 0.98 [25.00] | 1.757 [44.625] | 3.15 [80.07] |
| 43808-10 | 4914 (2 STAGE) 6123 | 1.38 [34.95] | 1.757 [44.625] | 3.54 [89.88] |
| 43808-11 | 5314 (0 STAGE) 2392 | 0.54 [13.84] | 2.490 [63.250] | 3.93 [99.77] |
| 43808-12 | 5314 (0 STAGE) 9223 | 0.54 [13.84] | 2.970 [75.445] | 3.93 [99.77] |
| 43808-13 | 5614 (1 STAGE) 2392 | 0.98 [25.00] | 2.490 [63.250] | 4.24 [107.57] |
| 43808-14 | 5614 (1 STAGE) 9223 | 0.98 [25.00] | 2.970 [75.445] | 4.24 [107.57] |
| 43808-15 | 6114 (2 STAGE) 9223 | TBD | TBD | TBD |

| | | | | |
|---|-------------------|--|---------------------------|------------------------|
| DRAWN BY Matthew Biron | DATE 2/25/2016 | VICOR SWD | | |
| UNLESS OTHERWISE SPECIFIED DIMENSIONS ARE : INCH / [MM] | | DWG HEAT SINK XF .900 TALL ADAPTERS | | |
| TOLERANCES ARE: DECIMALS ±0.01 [0.25] ANGLES ±1° X.XXX [X.XXX] = ±0.005 [0.127] | | SIZE C | CAGE CODE 67131 | DWG NO 43756 |
| THIRD ANGLE PROJECTION DO NOT SCALE DRAWING | | SCALE 2:1 | REV 1 | SHEET 1 OF 1 |