



PRODUCT SPECIFICATION

1.0 SCOPE

This Product Specification covers the printed circuit board (PCB) connector header, which contains two bays (28 + 28) with right angle bent blades and depopulated variants. The bays consist of a hybrid configuration of three rows of 0.50 terminals with a 2.0mm centerline (pitch) with tin (Sn) plating and two rows of 1.2mm terminals with a 4.0mm centerline (pitch) with tin (Sn) plating. The following sketches show the configuration of bays.

PC Board Terminal method uses 0.40 x 0.40 and 0.60 x 0.60 solder tails.

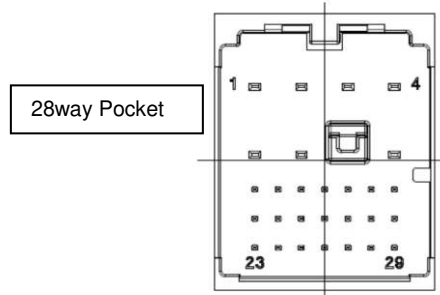
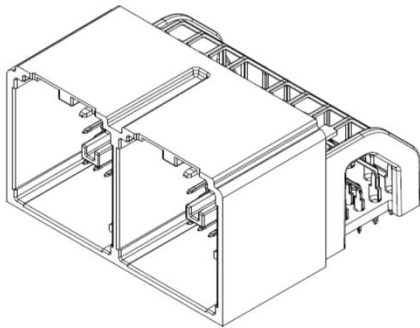

2.0 PRODUCT DESCRIPTION

2.1 PRODUCT NAME AND PART NUMBERS

- Infotainment Header Assembly
 - 1600130041 (56way) – Bay A (Key 4) & Bay B (Key 1)
 - 1600130023 (56way) – Bay A (Key 2) & Bay B (Key 3)
 - 1600131024 (32way) – Bay A (Key 2) & Bay B (Key 4)
 - 1600132041 (56way) – Bay A (Key 4) & Bay B (Key 1)
 - 1600133041 (56way) – Bay A (Key 4) & Bay B (Key 1)
 - 1600133023 (56way) – Bay A (Key 2) & Bay B (Key 3)
- Mating Harness Connectors
 - 1600140001 (28way) – Key 1 (Dark Gray)
 - 1600140002 (28way) – Key 2 (Light Green)
 - 1600140003 (28way) – Key 3 (Light Gray)
 - 1600140004 (28way) – Key 4 (Black)

REVISION: A2	ECR/ECN INFORMATION: EC No: UAU2016-1431 DATE: 2016 / 03 / 23	TITLE: stAK50h CONNECTOR SYSTEM 56way Infotainment Header	SHEET No. 1 of 8
DOCUMENT NUMBER: PS-160013-001	CREATED / REVISED BY: JIM CONDON	CHECKED BY: KURT DEKOSKI	APPROVED BY: KURT DEKOSKI



PRODUCT SPECIFICATION

2.2 MATERIALS, PLATINGS AND MARKINGS

- Header Housing - 30% glass-filled SPS (>SPS+GF30<) – Gray
- Pin Alignment Plate: 30% glass filled SPS (>SPS+GF30<) – Gray
- 1.20mm Power/Ground Blades – C26000 Brass (base material)
 - H06 Extra Hard
 - Underplate – Electro-deposited Sulphamate Nickel (Ni) Overall
 - Overplate:
 - Connector Side: Electro-deposited Tin (Sn) Reflowed
 - PCB Side: Electro-deposited Matte Tin (Sn)
- 0.50mm Signal Blades – C26000 Brass (base material)
 - H06 Extra Hard
 - Underplate – Electro-deposited Sulphamate Nickel (Ni) Overall
 - Overplate – Electro-deposited Tin (Sn) Reflowed (Overall)
- Readable Date Code: DDYY
 - DDD = “Day#” of the calendar year. (Example Feb 3rd = “034”)
 - YY = Calendar Year. (Example 2009 = “09”)

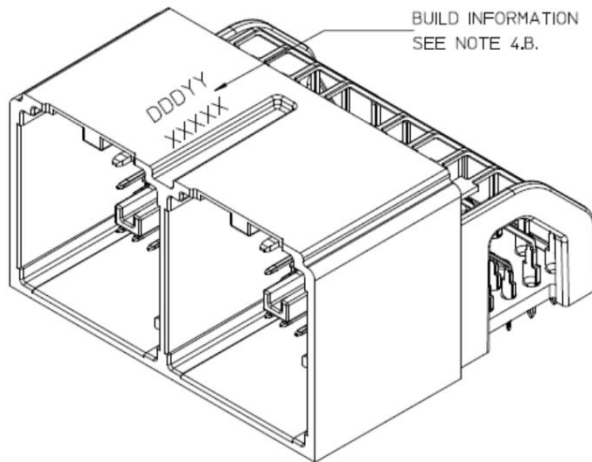

REVISION: A2	ECR/ECN INFORMATION: EC No: UAU2016-1431 DATE: 2016 / 03 / 23	TITLE: stAK50h CONNECTOR SYSTEM 56way Infotainment Header	SHEET No. 2 of 8
DOCUMENT NUMBER: PS-160013-001	CREATED / REVISED BY: JIM CONDON	CHECKED BY: KURT DEKOSKI	APPROVED BY: KURT DEKOSKI



PRODUCT SPECIFICATION

2.3 SAFETY AGENCY APPROVALS

UL File Number	UL94 – HB Flame Rating
CSA File Number	Not Applicable
TUV License number	Not Applicable
IMDS	Available Upon Request
Environmental Compliance	Available at molex.com

2.4 PCB SOLDER TAILS

- Exposed Solder Tail Length Options
 - Short Tail Option (2.1mm - Intended for Reflow Soldering i.e. Pin in Paste)
 - Long Tail Option (2.5mm - Intended for Wave Soldering)

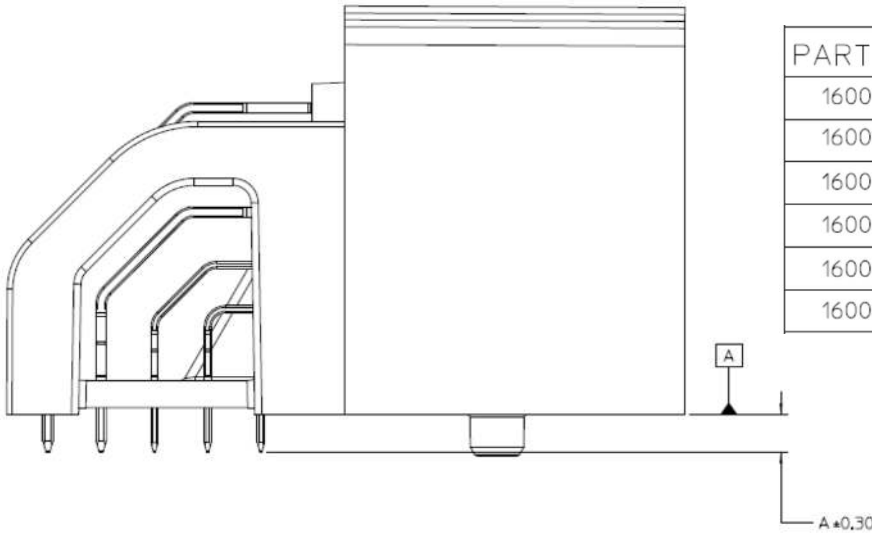

PART NUMBER	DIM A *
1600130041	2.1
1600132041	2.1
1600130023	2.1
1600131024	2.5
1600133041	2.5
1600133023	2.5

REVISION: A2	ECR/ECN INFORMATION: EC No: UAU2016-1431 DATE: 2016 / 03 / 23	TITLE: stAK50h CONNECTOR SYSTEM 56way Infotainment Header	SHEET No. 3 of 8
DOCUMENT NUMBER: PS-160013-001	CREATED / REVISED BY: JIM CONDON	CHECKED BY: KURT DEKOSKI	APPROVED BY: KURT DEKOSKI



PRODUCT SPECIFICATION

3.0 APPLICABLE DOCUMENTS AND SPECIFICATIONS

Description	Document Number
Header Assembly Drawing	SD-160013-0001
Mating Interface	SD-160014-002
Packaging Specification(s)	PK-31302-235 (Tube Pack) PK-160013-001 (Tray Pack)
Application Specification	AS-160013-001
Mating Connector Drawing	SD-160014-0001
GM Specification(s)	GMW3191 (Jun 2012)

4.0 RATINGS

4.1 VOLTAGE

500 VDC Minimum Dielectric Strength

4.2 CURRENT AND APPLICABLE WIRES

Current is dependent on harness connector.

Refer to Connector Product Specification: PS-160014-001 (TBD)

4.3 TEMPERATURE

GMW3191 (Jun 2012) – Temperature Class 1 (-40°C to +85°C)

Operating: - 40 C° to + 85 C°

Non-operating: - 40 C° to + 85 C°

Reflow Solder Capable per Molex ES-40000-5013 (260° C Max Temperature Profile)

4.4 VIBRATION

GMW3191 (Jun 2012) – Vibration Class 1 (On Body or Chassis)

4.5 SEALING

GMW3191 (Jun 2012) – Sealing Class 1 (Unsealed)

REVISION: A2	ECR/ECN INFORMATION: EC No: UAU2016-1431 DATE: 2016 / 03 / 23	TITLE: stAK50h CONNECTOR SYSTEM 56way Infotainment Header	SHEET No. 4 of 8
DOCUMENT NUMBER: PS-160013-001	CREATED / REVISED BY: JIM CONDON	CHECKED BY: KURT DEKOSKI	APPROVED BY: KURT DEKOSKI



PRODUCT SPECIFICATION

5.0 PERFORMANCE

- See DVPR 1998 for DV Test Results (TS-160013-1998)
- See DVPR 2291 for PV Test Results (TS-160013-2291)
- See DVPR 2028 for DV Harness Connector Test Results (TS-160014-2028)

8.1 ELECTRICAL REQUIREMENTS

ITEM	DESCRIPTION	TEST CONDITION	REQUIREMENT
1	Contact Resistance (Low Level)	Mate connectors: limiting the open circuit voltage of 20 mV and a maximum current of 100 mA .	0.50 terminals = 25 milliohms MAXIMUM
			1.2 terminals = 13 milliohms MAXIMUM
2	Contact Resistance @ Rated Current (Voltage Drop)	Mate connectors: apply a current of 3 ampere/ 0.35 mm² wire diameter	0.50 terminals = 25 milliohms MAXIMUM
		Mate connectors: apply a current of 13 ampere/ 1.0 mm² wire diameter	1.2 terminals = 13 milliohms MAXIMUM
3	Isolation Resistance	Apply a voltage of 500 VDC between adjacent terminals and between terminals to ground.	100 Meg ohms MINIMUM
4	Temperature Rise (via Current Cycling)	Mate terminals: measure the temperature rise at the rated current after: 1008 hours of bench top testing (45 minutes ON and 15 minutes OFF per hour).	Temperature rise over Ambient: +55 C° MAXIMUM

8.2 MECHANICAL REQUIREMENTS

ITEM	DESCRIPTION	TEST CONDITION	REQUIREMENT
5	Connector Mate/ Unmate Forces (Direct Mate)	Mate and unmate connector (male to female) at a rate of 50 ± 10 mm (2 ± ½ inch) per minute.	75 Newtons MAXIMUM

REVISION: A2	ECR/ECN INFORMATION: EC No: UAU2016-1431 DATE: 2016 / 03 / 23	TITLE: stAK50h CONNECTOR SYSTEM 56way Infotainment Header	SHEET No. 5 of 8
DOCUMENT NUMBER: PS-160013-001	CREATED / REVISED BY: JIM CONDON	CHECKED BY: KURT DEKOSKI	APPROVED BY: KURT DEKOSKI



PRODUCT SPECIFICATION

6	Polarization Feature Effectiveness	Connector must be polarized to prevent mating with similar connectors or incorrect orientation	185 Newtons MINIMUM
7	Header Pin Retention	Apply an axial insertion force on the terminal in the housing at a rate of 50 ± 10 mm (2 ± ½ inch) per minute.	0.50 terminals = 15 Newtons MINIMUM
			1.2 terminals = 50 Newtons MINIMUM

8.3 ENVIROMENTAL REQUIREMENTS

ITEM	DESCRIPTION	TEST CONDITION	REQUIREMENT
8	Durability	Mate connectors up to 10 cycles prior to environmental tests.	0.50 terminals = 25 milliohms MAXIMUM & Discontinuity < 1 microsecond
			1.2 terminals = 13 milliohms MAXIMUM & Discontinuity < 1 microsecond
9	Thermal Shock (Electrical)	Mate connectors per durability; expose to 100 cycles of: <u>Temperature C°</u> <u>Duration (Minutes)</u> -40 +0/-3 30 +85 +3/-0 30	0.50 terminals = 25 milliohms MAXIMUM & Discontinuity < 1 microsecond
			1.2 terminals = 13 milliohms MAXIMUM & Discontinuity < 1 microsecond
10	High Temperature Exposure (Electrical)	Mate connectors per durability and expose to 1008 hours at 85 ± 2°C	Isolation Resistance of 100 Meg ohms @ 500 VDC MINIMUM
			0.50 terminals = 25 milliohms MAXIMUM & Discontinuity < 1 microsecond
			1.2 terminals = 13 milliohms MAXIMUM & Discontinuity < 1 microsecond
11	Cyclic Humid Heat (Electrical)	Mate connectors per durability and expose connector system to five 48 -hour cycles of combined heating and humidity exposure	Isolation Resistance of 100 Meg ohms @ 500 VDC MINIMUM

REVISION:	ECR/ECN INFORMATION:	TITLE:	SHEET No.
A2	EC No: UAU2016-1431 DATE: 2016 / 03 / 23	stAK50h CONNECTOR SYSTEM 56way Infotainment Header	6 of 8

DOCUMENT NUMBER:	CREATED / REVISED BY:	CHECKED BY:	APPROVED BY:
PS-160013-001	JIM CONDON	KURT DEKOSKI	KURT DEKOSKI



PRODUCT SPECIFICATION

		-10 °C and 65 °C at 80% to 93% RH	0.50 terminals = 25 milliohms MAXIMUM & Discontinuity < 1 microsecond
			1.2 terminals = 13 milliohms MAXIMUM & Discontinuity < 1 microsecond
12	Constant Humid Heat (Electrical)	Mate connectors per durability and expose connector system to 10 days of constant exposure at 85 ± 3°C at 90± 5% RH	Isolation Resistance of 100 Meg ohms @ 500 VDC MINIMUM
			0.50 terminals = 25 milliohms MAXIMUM & Discontinuity < 1 microsecond
			1.2 terminals = 13 milliohms MAXIMUM & Discontinuity < 1 microsecond
13	Vibration/ Mechanical Shock (Electrical)	Mate connectors per durability. Connector assembly shall be vibrated for 2X Life (16 hours / axis, 792 shocks @ 25 Gs / axis, 18 shocks @ 100 Gs/axis) on body sprung mass not coupled to engine.	0.50 terminals = 25 milliohms MAXIMUM & Discontinuity < 1 microsecond
			1.2 terminals = 13 milliohms MAXIMUM & Discontinuity < 1 microsecond

6.0 PACKAGING

Parts shall be packaged to protect against damage during handling, transit and storage

See Packaging Specifications for details:
 PK-31302-235 (Tube Packaging Option)
 PK-160013-001 (Tray Packaging Option)

Tube Packaging Option, shown below:

REVISION: A2	ECR/ECN INFORMATION: EC No: UAU2016-1431 DATE: 2016 / 03 / 23	TITLE: stAK50h CONNECTOR SYSTEM 56way Infotainment Header	SHEET No. 7 of 8
DOCUMENT NUMBER: PS-160013-001	CREATED / REVISED BY: JIM CONDON	CHECKED BY: KURT DEKOSKI	APPROVED BY: KURT DEKOSKI



PRODUCT SPECIFICATION

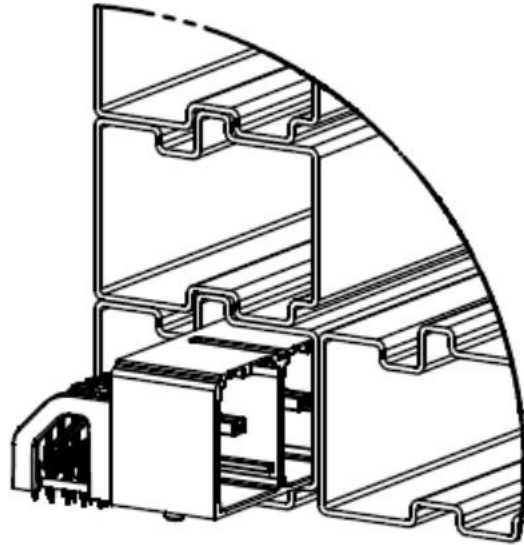

Tray Packaging Option:

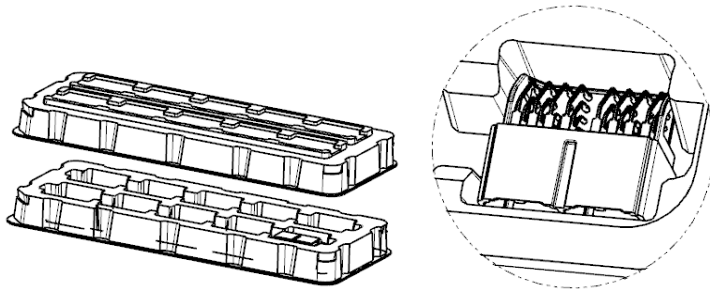

7.0 GAGES AND FIXTURES

All applicable gages and fixtures are referenced in the appropriate control plans.

8.0 OTHER INFORMATION

Products conform to Connector Specifications:

GMW3191 (June 2012): Temperature Class (T1), Sealing Class (S1), Vibration Class (V1)

REVISION: A2	ECR/ECN INFORMATION: EC No: UAU2016-1431 DATE: 2016 / 03 / 23	TITLE: stAK50h CONNECTOR SYSTEM 56way Infotainment Header	SHEET No. 8 of 8
DOCUMENT NUMBER: PS-160013-001	CREATED / REVISED BY: JIM CONDON	CHECKED BY: KURT DEKOSKI	APPROVED BY: KURT DEKOSKI