

LOC	DIST	REV	DESCRIPTION	DATE	BY	APPV
DF	AO	B	REVISED PER ECO-13-002054	05FEB2013	MGM	CT

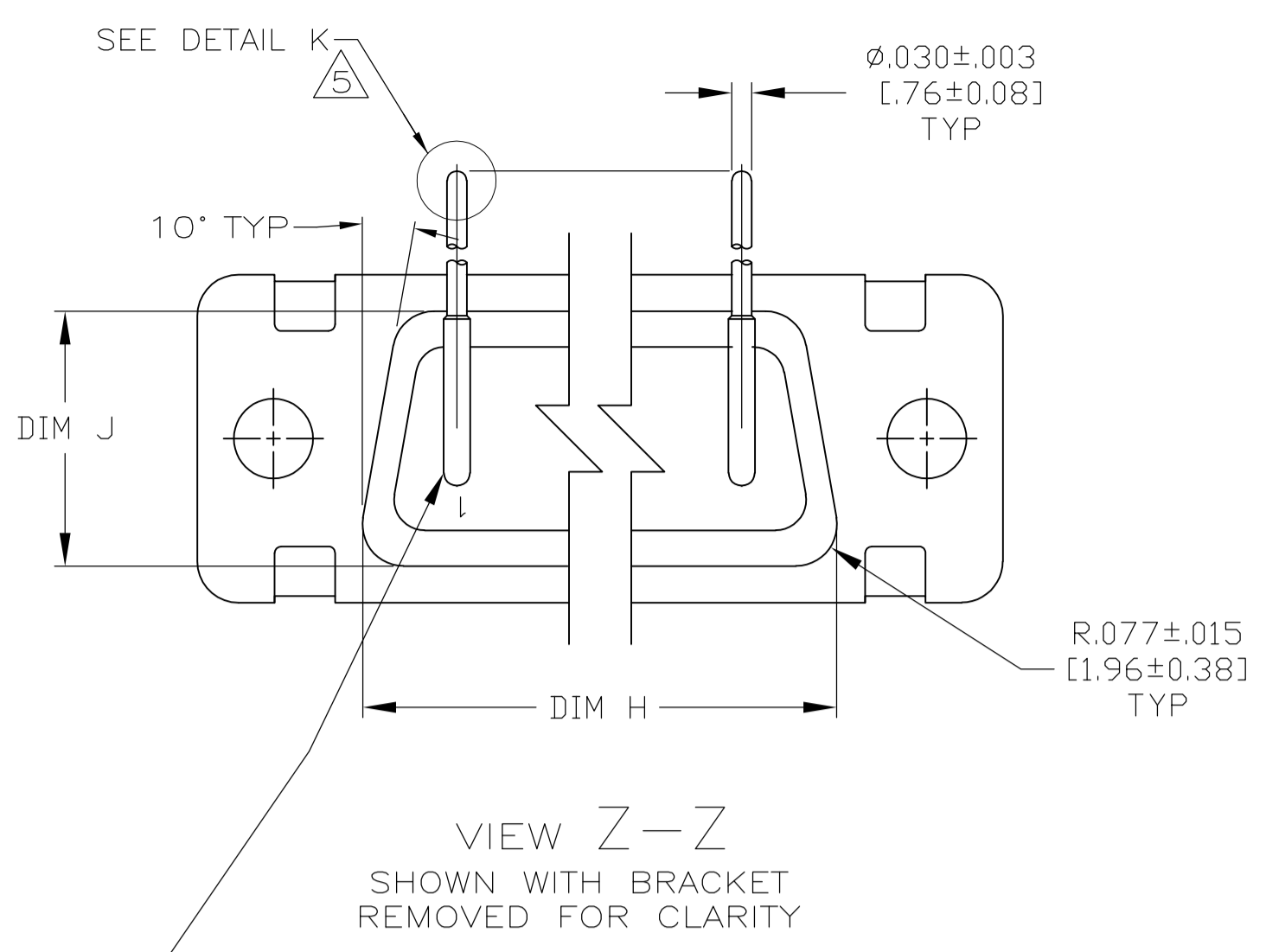
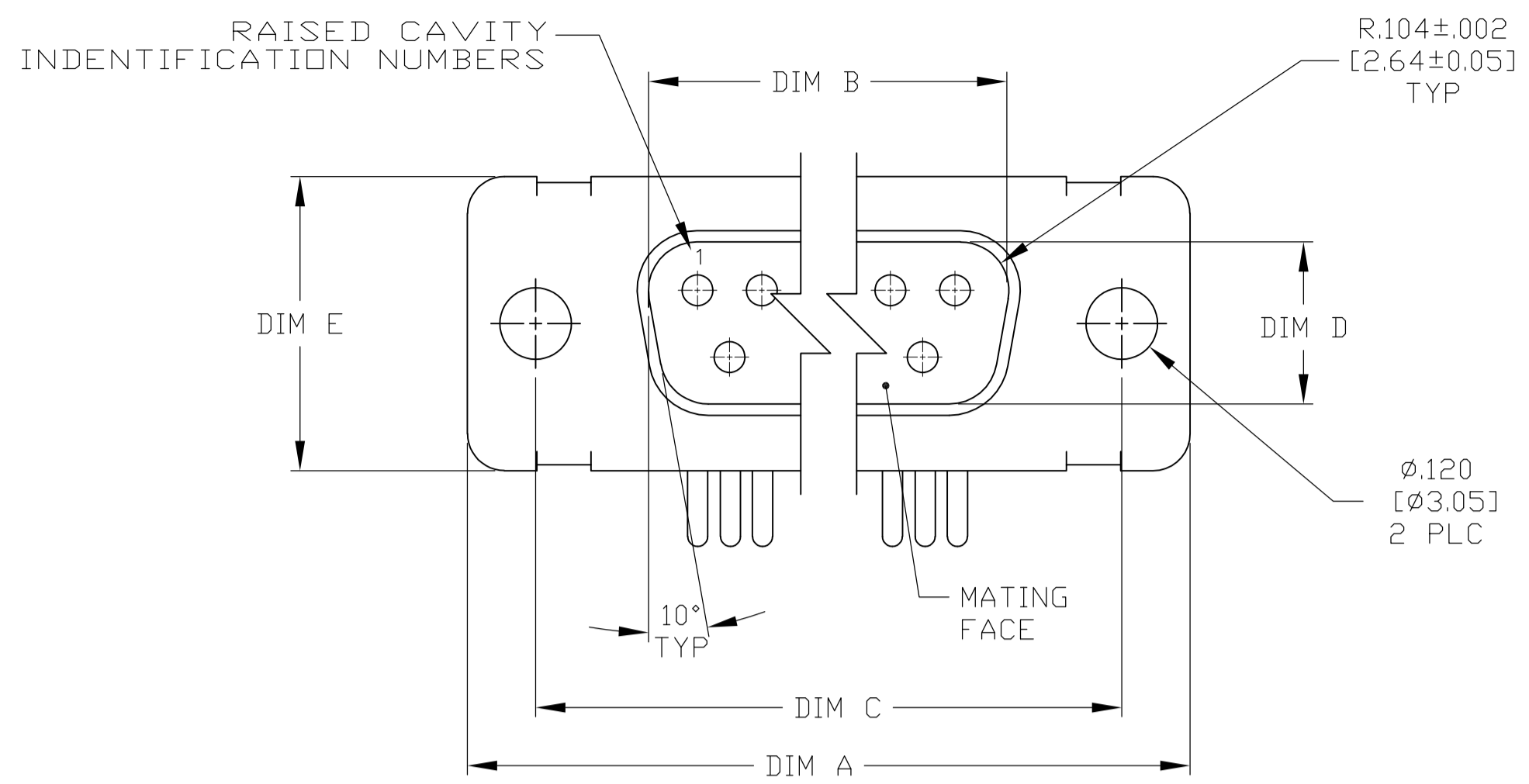

VIEW Z-Z
SHOWN WITH BRACKET REMOVED FOR CLARITY

CONTACT (QTY = NO. OF POSN)
MATL: BRASS PER ASTM-B-16, OR BERYLLIUM COPPER PER ASTM-B-194
FINISH: GOLD PER ASTM-B-488, TYPE II, GRADE C, CLASS 1.27 IN CONTACT MATING AREA, .000010 [0.0003] MIN THK GOLD PER ASTM-B-488 OVER .000050 [0.0013] MIN THK NICKEL PER SAE-AMS-QQ-N-290 ON CONTACT BODY

- SEE SHEET 2 FOR RECOMMENDED P.C. BOARD LAYOUT. TRUE POSITION TOLERANCE FOR P.C. BOARD LAYOUT IS .010 [0.25] AT MAX MATERIAL CONDITION. SUGGESTED BOARD THICKNESS IS .062 [1.57]
- THE CONNECTORS DESCRIBED IN THIS DOCUMENT MEET THE REQUIREMENTS OF MIL-C-24308 AND MATE WITH ANY RECEPTACLE CONNECTOR WITH SAME INSERT ARRANGEMENT.
- MARKED WITH .047 [1.19]-.062 [1.57] HIGH CHARACTERS. FAR SIDE REFERS TO THE WIDE SIDE OF THE KEYSTONE. NEAR SIDE REFERS TO THE NARROW SIDE OF THE KEYSTONE. IF THE SHELL IS TOO SMALL FOR THE ENTIRE MARKING MARKING SHALL BE SPLIT AS FOLLOWS:
A. "M24308" ON FRONT SHELL, FAR SIDE.
B. SLASH SHEET AND DASH NUMBER ON REAR SHELL, FAR SIDE.
C. "MFG'S" (NAME, BRAND OR LOGO), AND DATE CODE ON FRONT SHELL, NEAR SIDE.
D. MFG'S PART NUMBER ON REAR SHELL, NEAR SIDE.
- REQUIREMENT FOR FULL PIN DIAMETER EXTENSION:
.159 [4.04] MIN, SHELL SIZES 1 AND 2.
.150 [3.81] MIN, SHELL SIZES 3 AND 4.
- SOLDER DIPPED PER J-STD-001 WITH Sn63 SOLDER PER J-STD-006 IN THE ENTIRE AREA OF DIMENSION SHOWN. (1757835-6 THRU -10 ONLY.)
- MEETS SOLDERABILITY PER MIL-STD-202 METHOD 208.

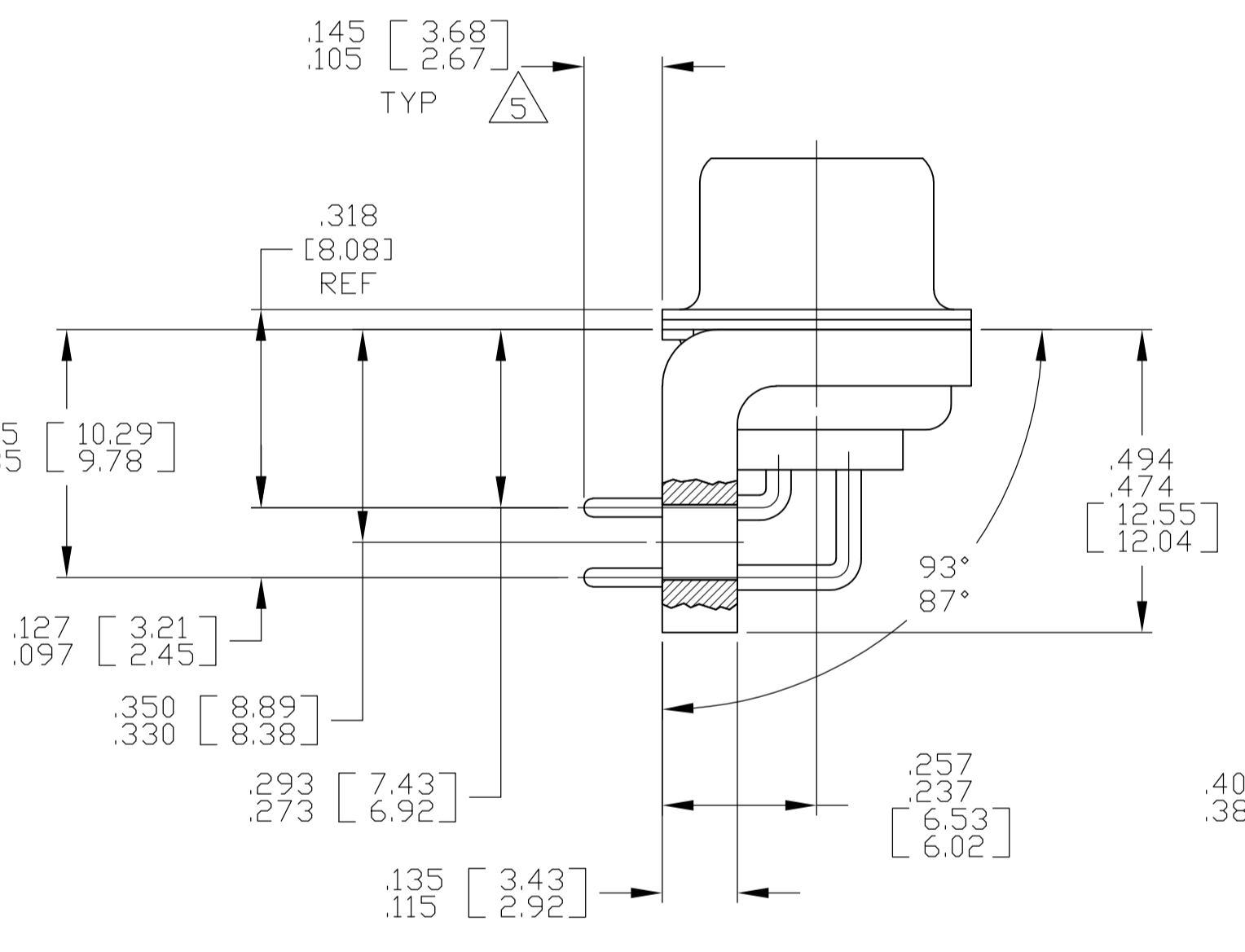
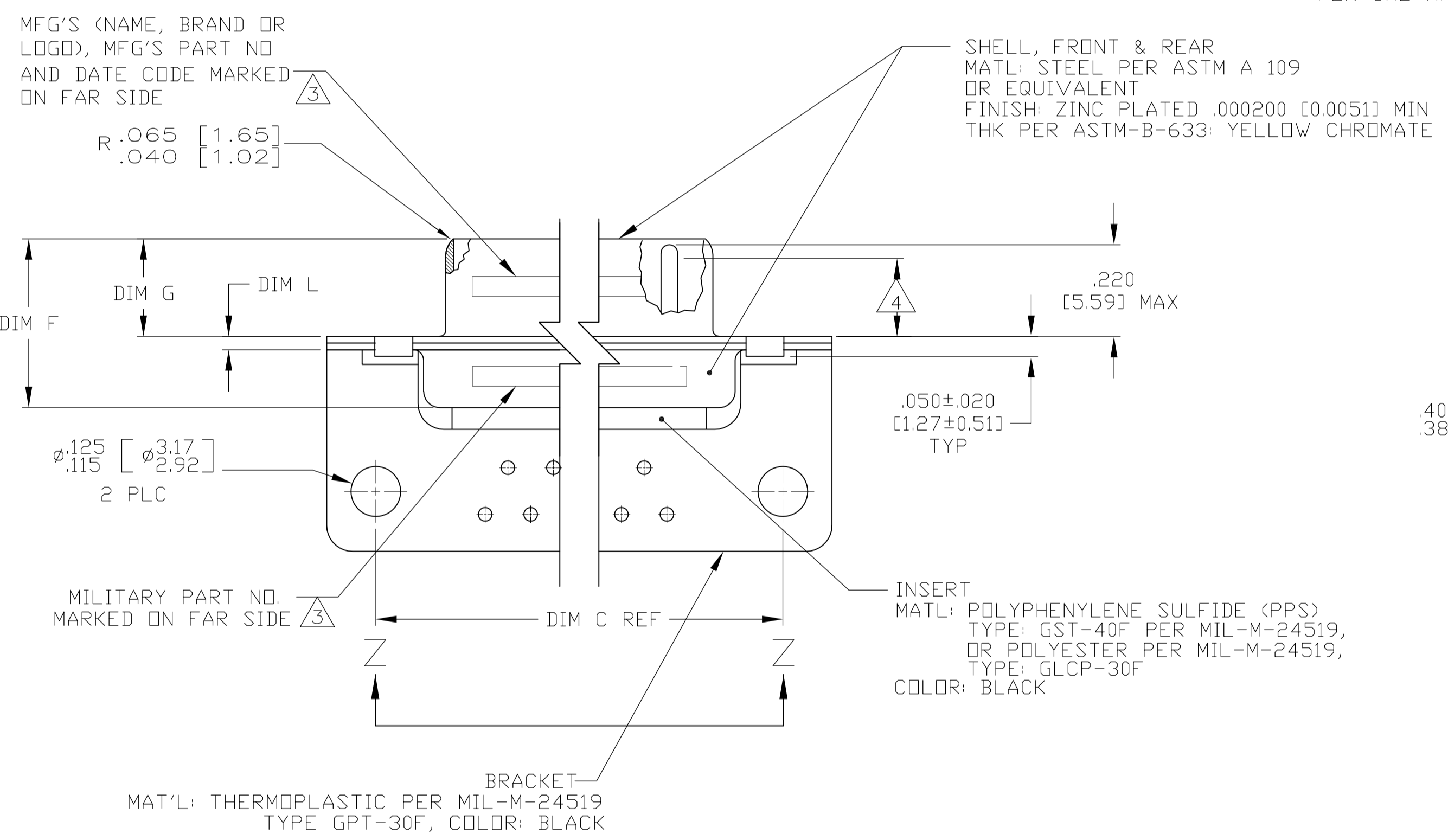

SHELL SIZES 1 THRU 4 CONTACT CONFIGURATION

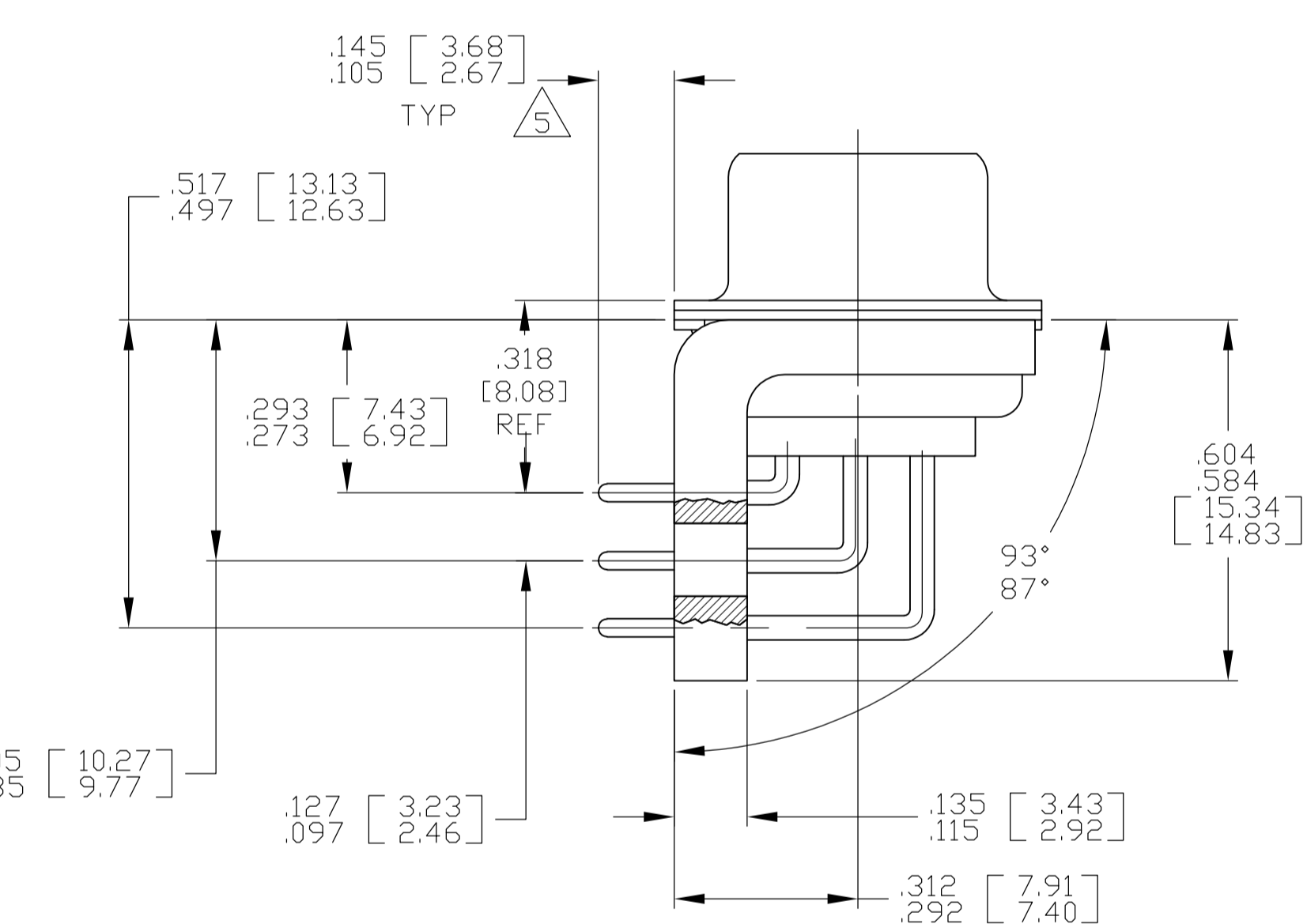

SHELL SIZE 5 CONTACT CONFIGURATION

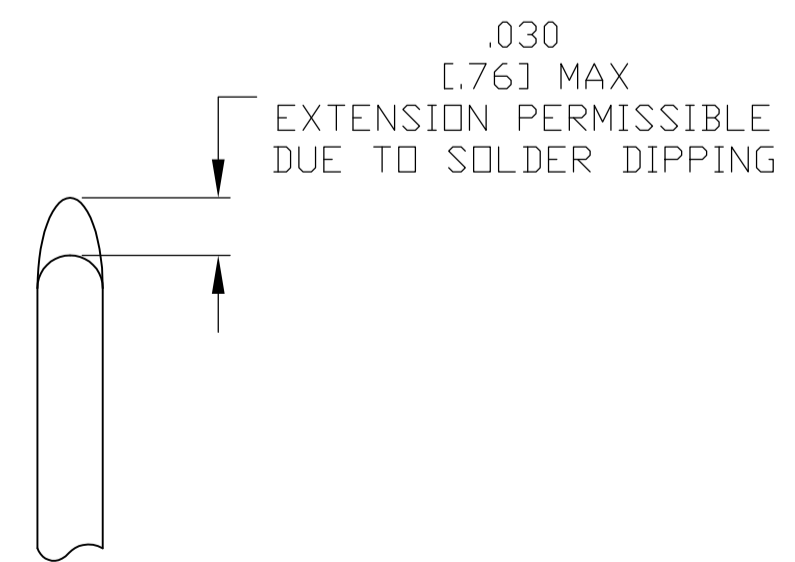

DETAIL K SCALE 10:1 FOR 1757835-6 THRU -10 ONLY

.049	.124	.544	13.82	2.188	55.58	.236	5.99	.436	11.07	.620	15.75	.446	11.33	2.411	61.24	2.084	52.55	2.650	67.31
.029	[0.74]	.524	[13.31]	2.168	[55.07]	.224	[5.69]	.416	[10.57]	.590	[14.99]	.436	[11.07]	2.401	[60.99]	2.074	[52.30]	2.620	[66.55]
.049	.124	.432	10.97	2.282	57.96	.236	5.99	.436	11.07	.509	12.93	.334	8.48	2.505	63.63	2.187	54.97	2.744	69.70
.029	[0.74]	.412	[10.46]	2.262	[57.45]	.224	[5.69]	.416	[10.57]	.479	[12.17]	.324	[8.23]	2.495	[63.37]	2.177	[54.71]	2.714	[68.94]
.049	.124	.432	10.97	1.635	41.53	.236	5.99	.436	11.07	.509	12.93	.334	8.48	1.857	47.17	1.539	38.51	2.103	53.42
.029	[0.74]	.412	[10.46]	1.615	[41.02]	.224	[5.69]	.416	[10.57]	.479	[12.17]	.324	[8.23]	1.847	[46.91]	1.529	[38.25]	2.073	[52.65]
.040	1.02	.432	10.97	1.093	27.76	.238	6.05	.432	10.97	.509	12.93	.334	8.48	1.317	33.45	.999	24.79	1.556	39.52
.020	[0.51]	.412	[10.46]	1.073	[27.25]	.229	[5.82]	.412	[10.46]	.479	[12.17]	.324	[8.23]	1.307	[33.20]	.989	[24.54]	1.526	[38.76]
.040	1.02	.432	10.97	.769	19.53	.238	6.05	.432	10.97	.509	12.93	.334	8.48	.989	25.12	.671	16.46	1.228	31.19
.020	[0.51]	.412	[10.46]	.749	[19.02]	.229	[5.82]	.412	[10.46]	.479	[12.17]	.324	[8.23]	.979	[24.87]	.661	[16.21]	1.198	[30.43]
.049	.124	.544	13.82	2.188	55.58	.236	5.99	.436	11.07	.620	15.75	.446	11.33	2.411	61.24	2.084	52.55	2.650	67.31
.029	[0.74]	.524	[13.31]	2.168	[55.07]	.224	[5.69]	.416	[10.57]	.590	[14.99]	.436	[11.07]	2.401	[60.99]	2.074	[52.30]	2.620	[66.55]
.049	.124	.432	10.97	2.282	57.96	.236	5.99	.436	11.07	.509	12.93	.334	8.48	2.505	63.63	2.187	54.97	2.744	69.70
.029	[0.74]	.412	[10.46]	2.262	[57.45]	.224	[5.69]	.416	[10.57]	.479	[12.17]	.324	[8.23]	2.495	[63.37]	2.177	[54.71]	2.714	[68.94]
.049	.124	.432	10.97	1.635	41.53	.236	5.99	.436	11.07	.509	12.93	.334	8.48	1.857	47.17	1.539	38.51	2.103	53.42
.029	[0.74]	.412	[10.46]	1.615	[41.02]	.224	[5.69]	.416	[10.57]	.479	[12.17]	.324	[8.23]	1.847	[46.91]	1.529	[38.25]	2.073	[52.65]
.040	1.02	.432	10.97	1.093	27.76	.238	6.05	.432	10.97	.509	12.93	.334	8.48	1.317	33.45	.999	24.79	1.556	39.52
.020	[0.51]	.412	[10.46]	1.073	[27.25]	.229	[5.82]	.412	[10.46]	.479	[12.17]	.324	[8.23]	1.307	[33.20]	.989	[24.54]	1.526	[38.76]
.049	.124	.544	13.82	2.188	55.58	.236	5.99	.436	11.07	.620	15.75	.446	11.33	2.411	61.24	2.084	52.55	2.650	67.31
.029	[0.74]	.524	[13.31]	2.168	[55.07]	.224	[5.69]	.416	[10.57]	.590	[14.99]	.436	[11.07]	2.401	[60.99]	2.074	[52.30]	2.620	[66.55]
.049	.124	.432	10.97	2.282	57.96	.236	5.99	.436	11.07	.509	12.93	.334	8.48	2.505	63.63	2.187	54.97	2.744	69.70
.029	[0.74]	.412	[10.46]	2.262	[57.45]	.224	[5.69]	.416	[10.57]	.479	[12.17]	.324	[8.23]	2.495	[63.37]	2.177	[54.71]	2.714	[68.94]
.049	.124	.432	10.97	1.635	41.53	.236	5.99	.436	11.07	.509	12.93	.334	8.48	1.857	47.17	1.539	38.51	2.103	53.42
.029	[0.74]	.412	[10.46]	1.615	[41.02]	.224	[5.69]	.416	[10.57]	.479	[12.17]	.324	[8.23]	1.847	[46.91]	1.529	[38.25]	2.073	[52.65]
.040	1.02	.432	10.97	1.093	27.76	.238	6.05	.432	10.97	.509	12.93	.334	8.48	1.317	33.45	.999	24.79	1.556	39.52
.020	[0.51]	.412	[10.46]	1.073	[27.25]	.229	[5.82]	.412	[10.46]	.479	[12.17]	.324	[8.23]	1.307	[33.20]	.989	[24.54]	1.526	[38.76]
.040	1.02	.432	10.97	.769	19.53	.238	6.05	.432	10.97	.509	12.93	.334	8.48	.989	25.12	.671	16.46	1.228	31.19
.020	[0.51]	.412	[10.46]	.749	[19.02]	.229	[5.82]	.412	[10.46]	.479	[12.17]	.324	[8.23]	.979	[24.87]	.661	[16.21]	1.198	[30.43]

DIM L	DIM J	DIM H	DIM G	DIM F	DIM E	DIM D	DIM C	DIM B	DIM A	INSERT ARRANGEMENT	NO OF POS	SHELL SIZE	MILITARY P/N ON CONNECTOR	MFG'S P/N MARKED ON CONNECTOR	MFG'S PART NO.				
.049	.124	.544	13.82	2.188	55.58	.236	5.99	.436	11.07	.620	15.75	.446	11.33	2.411	61.24	2.084	52.55	2.650	67.31
.029	[0.74]	.524	[13.31]	2.168	[55.07]	.224	[5.69]	.416	[10.57]	.590	[14.99]	.436	[11.07]	2.401	[60.99]	2.074	[52.30]	2.620	[66.55]
.049	.124	.432	10.97	2.282	57.96	.236	5.99	.436	11.07	.509	12.93	.334	8.48	2.505	63.63	2.187	54.97	2.744	69.70
.029	[0.74]	.412	[10.46]	2.262	[57.45]	.224	[5.69]	.416	[10.57]	.479	[12.17]	.324	[8.23]	2.495	[63.37]	2.177	[54.71]	2.714	[68.94]
.049	.124	.432	10.97	1.635	41.53	.236	5.99	.436	11.07	.509	12.93	.334	8.48	1.857	47.17	1.539	38.51	2.103	53.42
.029	[0.74]	.412	[10.46]	1.615	[41.02]	.224	[5.69]	.416	[10.57]	.479	[12.17]	.324	[8.23]	1.847	[46.91]	1.529	[38.25]	2.073	[52.65]
.040	1.02	.432	10.97	1.093	27.76	.238	6.05	.432	10.97	.509	12.93	.334	8.48	1.317	33.45	.999	24.79	1.556	39.52
.020	[0.51]	.412	[10.46]	1.073	[27.25]	.229	[5.82]	.412	[10.46]	.479	[12.17]	.324	[8.23]	1.307	[33.20]	.989	[24.54]	1.526	[38.76]
.049	.124	.544	13.82	2.188	55.58	.236	5.99	.436	11.07	.620	15.75	.446	11.33	2.411	61.24	2.084	52.55	2.650	67.31
.029	[0.74]	.524	[13.31]	2.168	[55.07]	.224	[5.69]	.416	[10.57]	.590	[14.99]	.436	[11.07]	2.401	[60.99]	2.074	[52.30]	2.620	[66.55]
.049	.124	.432	10.97	2.282	57.96	.236	5.99	.436	11.07	.509	12.93	.334	8.48	2.505	63.63	2.187	54.97	2.744	69.70
.029	[0.74]	.412	[10.46]	2.262	[57.45]	.224	[5.69]	.416	[10.57]	.479	[12.17]	.324	[8.23]	2.495	[63.37]	2.177	[54.71]	2.714	[68.94]
.049	.124	.432	10.97	1.635	41.53	.236	5.99	.436	11.07	.509	12.93	.334	8.48	1.857	47.17	1.539	38.51	2.103	53.42
.029	[0.74]	.412	[10.46]	1.615	[41.02]	.224	[5.69]	.416	[10.57]	.479	[12.17]	.324	[8.23]	1.847	[46.91]	1.529	[38.25]	2.073	[52.65]
.040	1.02	.432	10.97	1.093	27.76	.238	6.05	.432	10.97	.509	12.93	.334	8.48	1.317	33.45	.999	24.79	1.556	39.52
.020	[0.51]	.412	[10.46]	1.073	[27.25]	.229	[5.82]	.412	[10.46]	.479	[12.17]	.324	[8.23]	1.307	[33.20]	.989	[24.54]	1.526	[38.76]
.040	1.02	.432	10.97	.769	19.53	.238	6.05	.432	10.97	.509	12.93	.334	8.48	.989	25.12	.671	16.46	1.228	31.19
.020	[0.51]	.412	[10.46]	.749	[19.02]	.229	[5.82]	.412	[10.46]	.479	[12.17]	.324	[8.23]	.979	[24.87]	.661	[16.21]	1.198	[30.43]

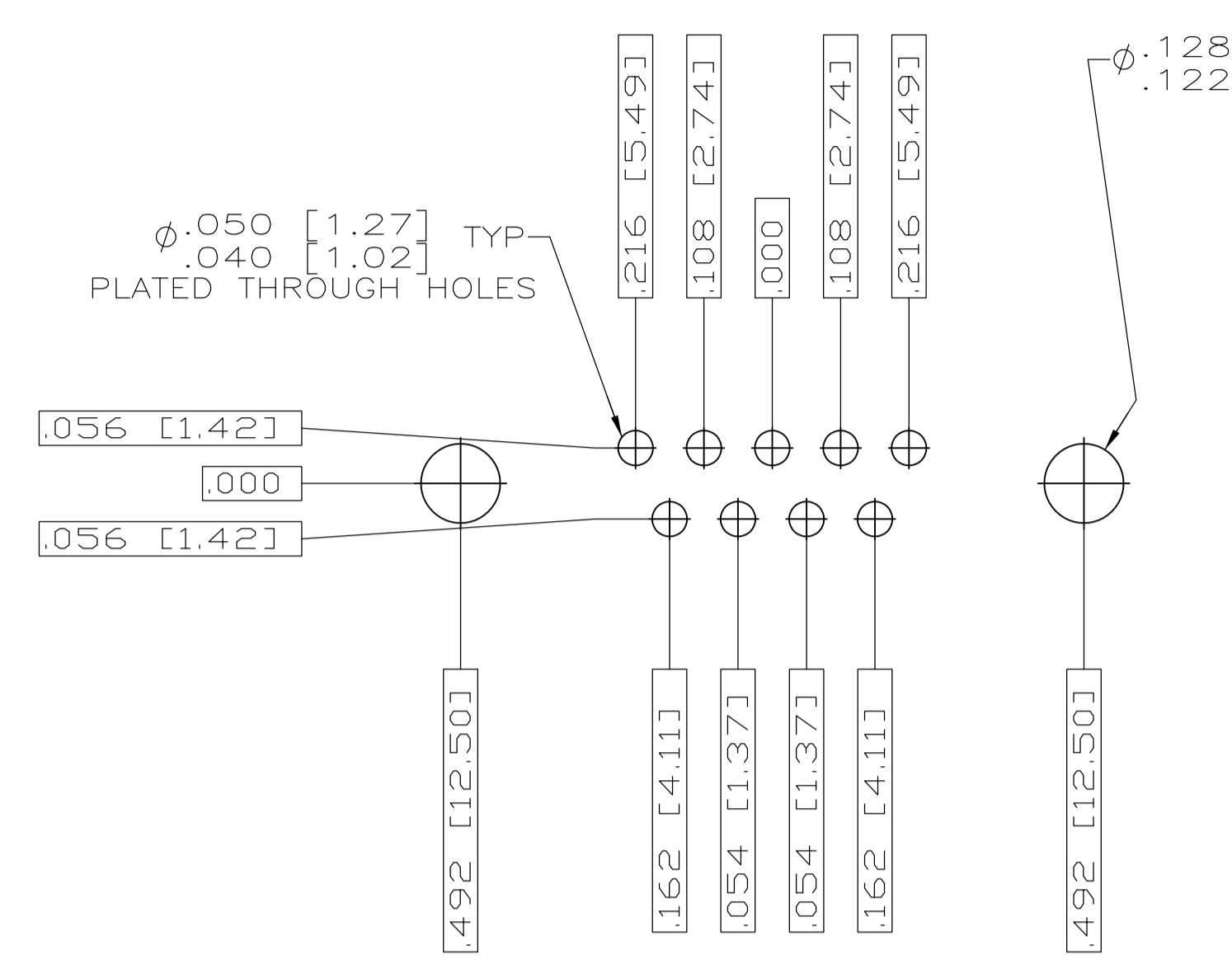

RECOMMENDED P.C. BOARD LAYOUT
SHELL SIZE 1 (9 POSITION) ⚠

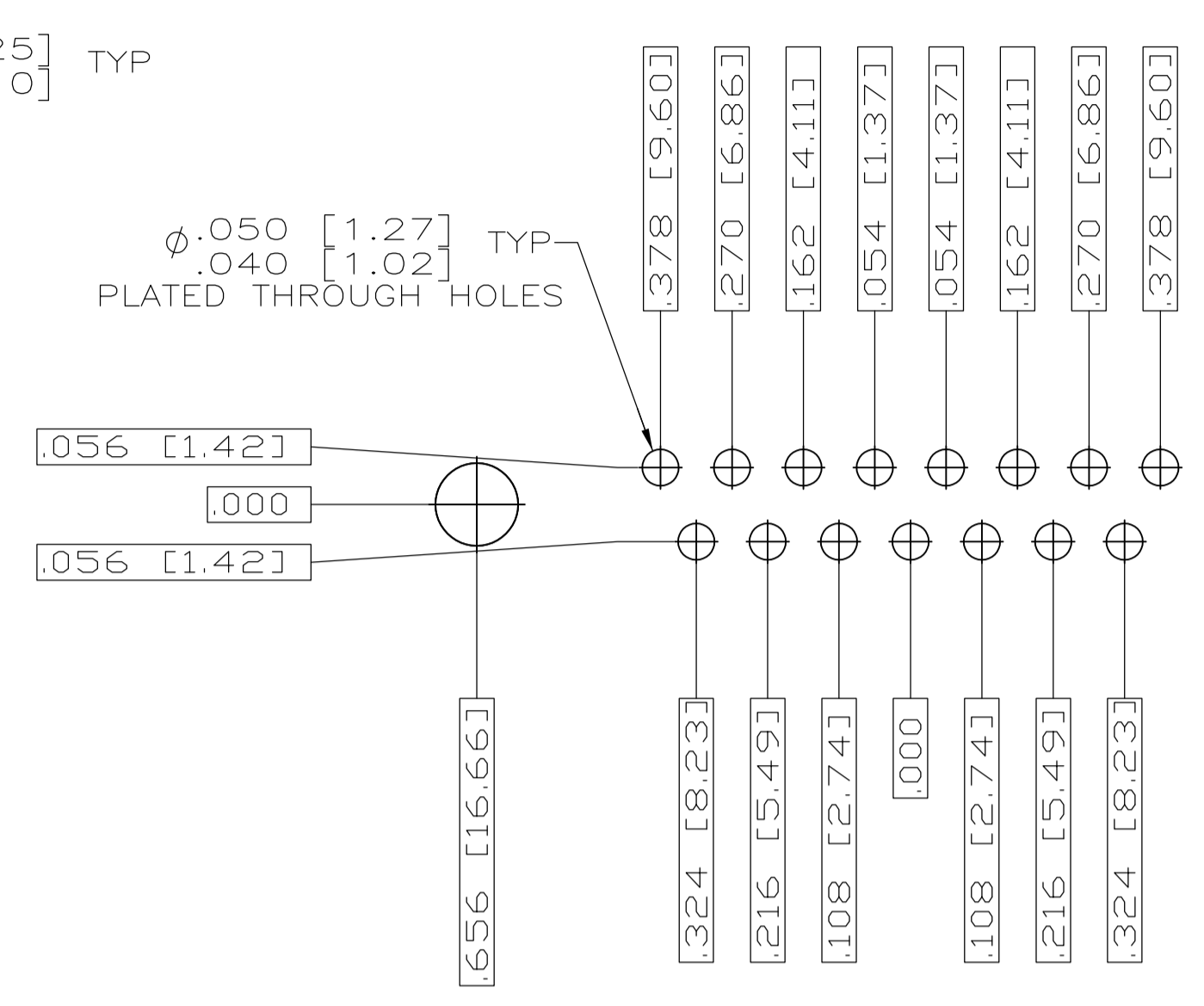

RECOMMENDED P.C. BOARD LAYOUT
SHELL SIZE 2 (15 POSITION) ⚠

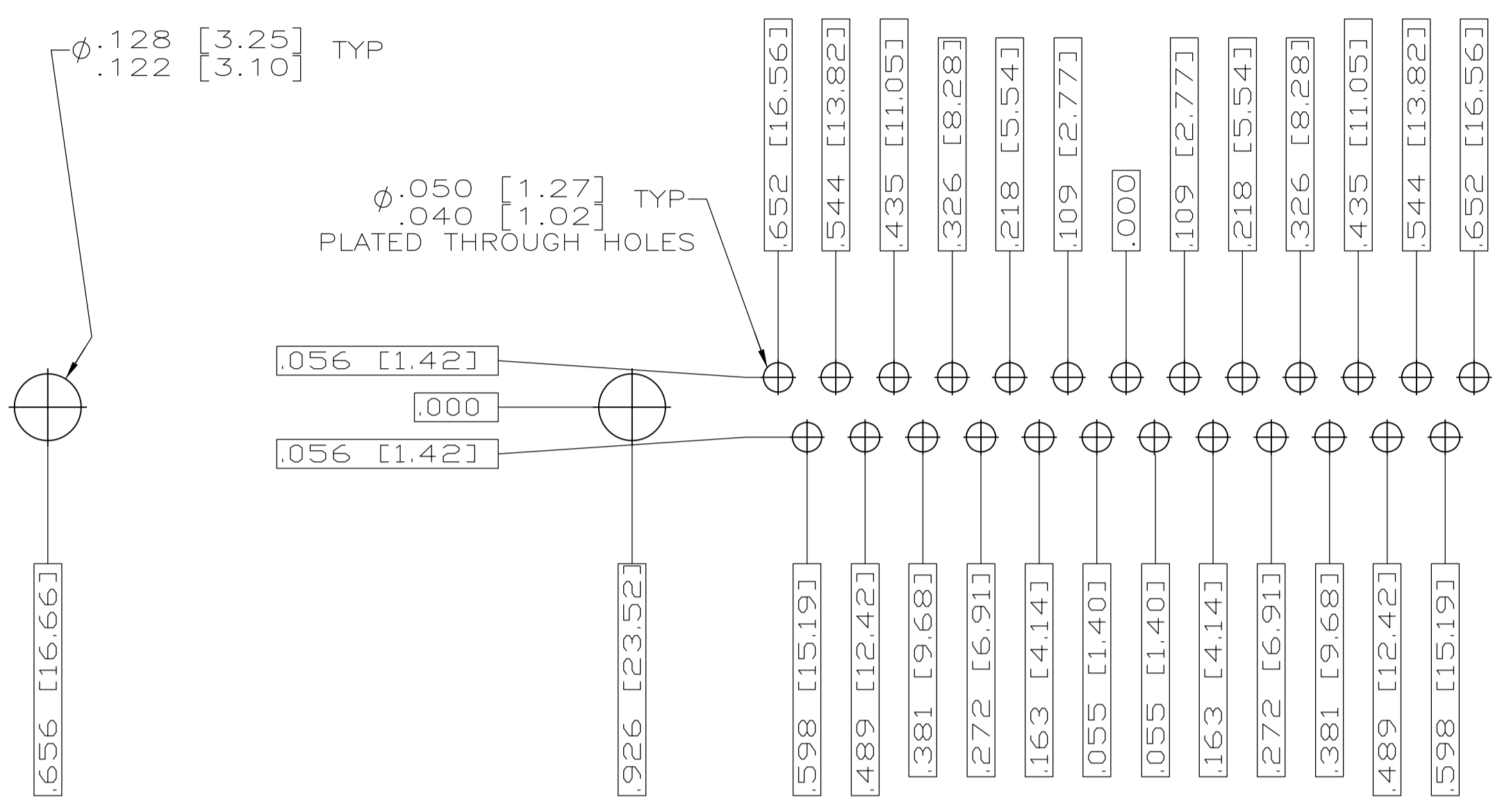

RECOMMENDED P.C. BOARD LAYOUT
SHELL SIZE 3 (25 POSITION) ⚠

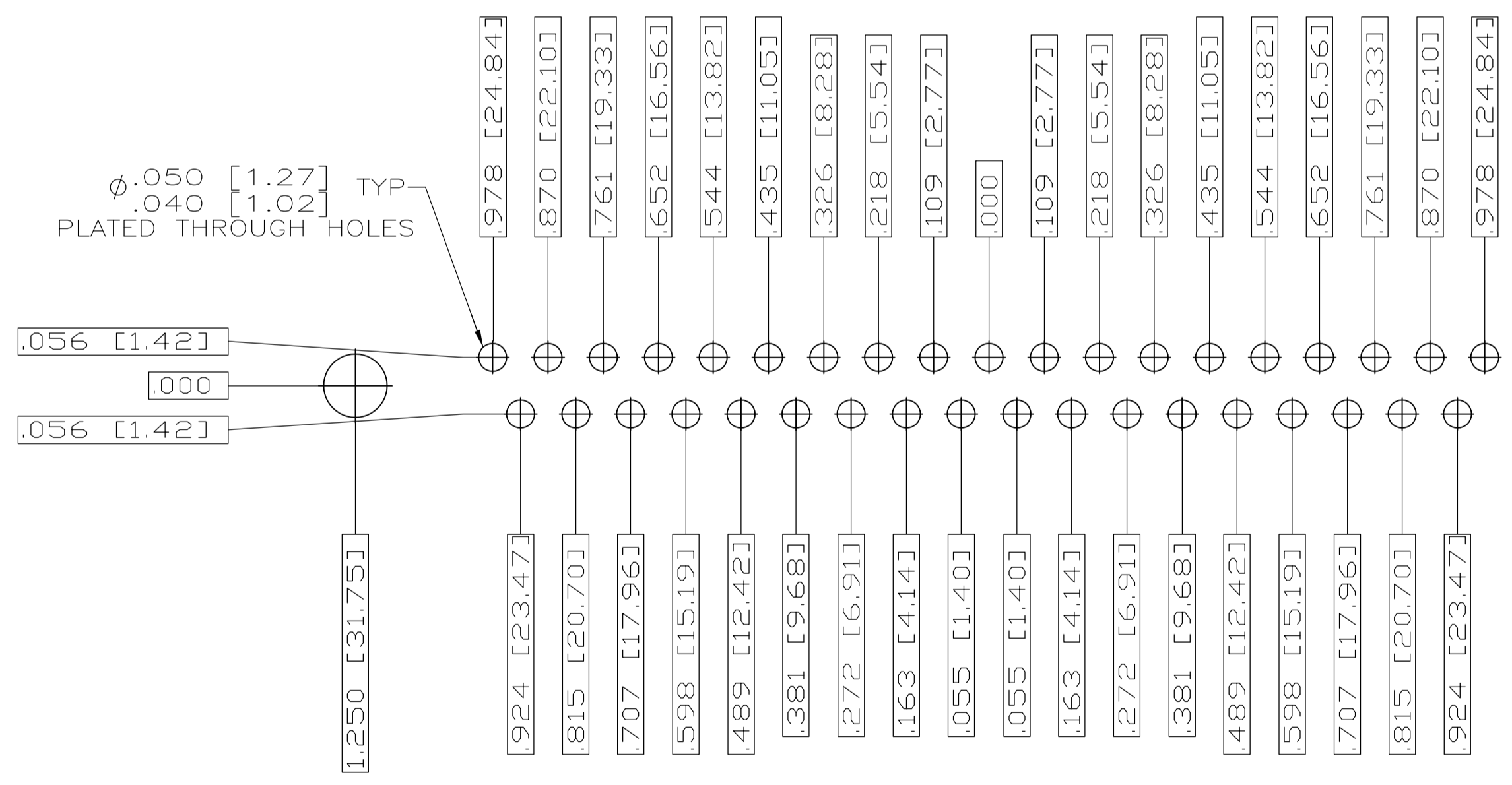

RECOMMENDED P.C. BOARD LAYOUT
SHELL SIZE 4 (37 POSITION) ⚠

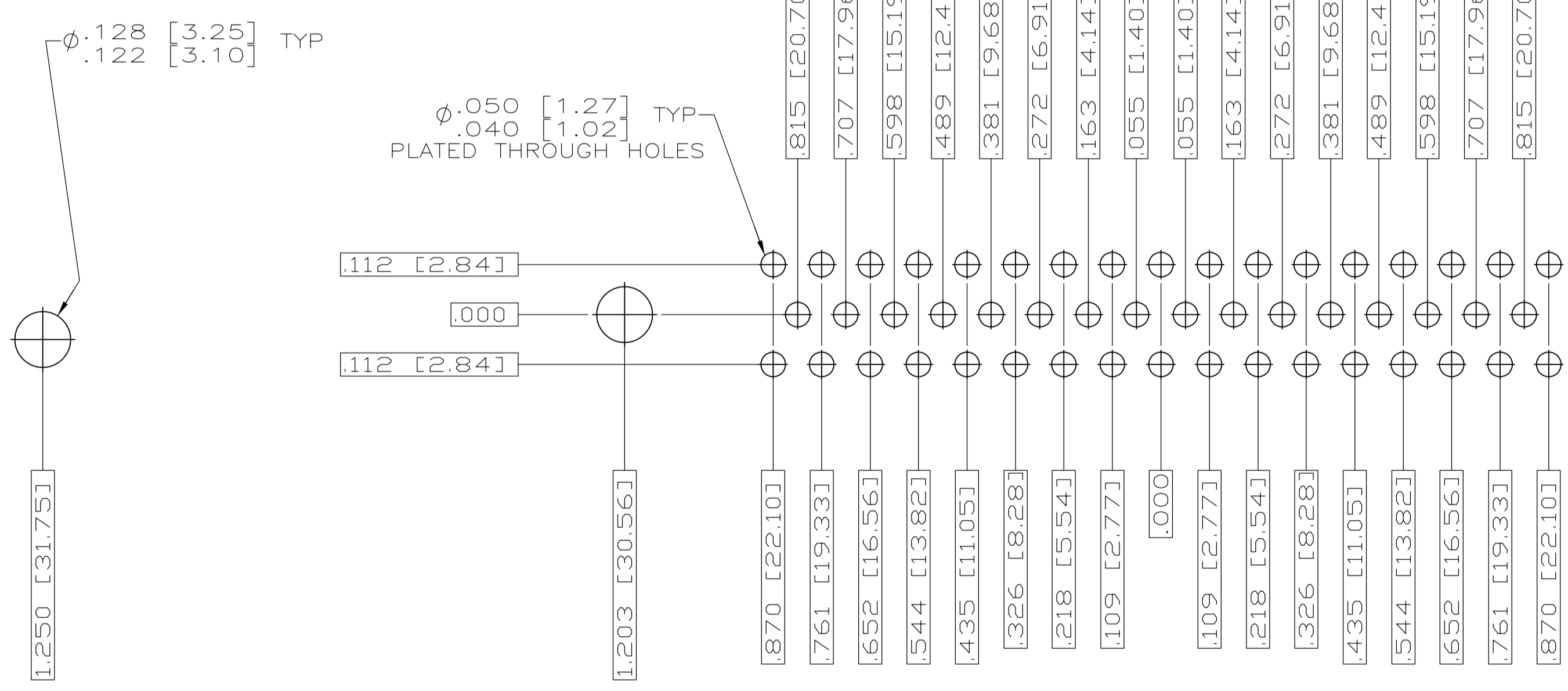

RECOMMENDED P.C. BOARD LAYOUT
SHELL SIZE 5 (50 POSITION) ⚠

THIS DRAWING IS A CONTROLLED DOCUMENT.		DN C.C.THOMAS	2-10-06		TE Connectivity	
DIMENSIONS: INCHES		CHK D.HOFFMAN	2-13-06		NAME PLUG ASSY,AMPLIMITE RIGHT ANGLE,SERIES 109,SIZE 1 THRU 5	
TOLERANCES UNLESS OTHERWISE SPECIFIED:		APP'D D.MILLER	2-13-06	APPLICATION SPEC		
0 PL ± .005		MATERIAL SEE CALLOUTS		SIZE A1		
1 PL ± .005		FINISH SEE CALLOUTS		CAGE CODE 00779		
2 PL ± .005		WEIGHT		DRAWING NO 1757835		
3 PL ± .005		CUSTOMER DRAWING		SCALE 4:1		
4 PL ± .005		RESTRICTED TO		SHEET 2 OF 2		
ANGLES ± .1°		REV		REV		