

REVISIONS			
REV	DESCRIPTION, ECN, EAR NO.	DATE	APP'D
A	PROPOSAL	SEP 26/17	L.CHAN

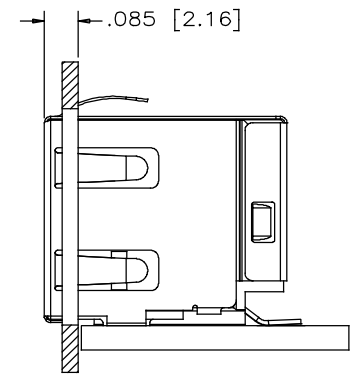

RECOMMENDED PANEL CUT-OUT

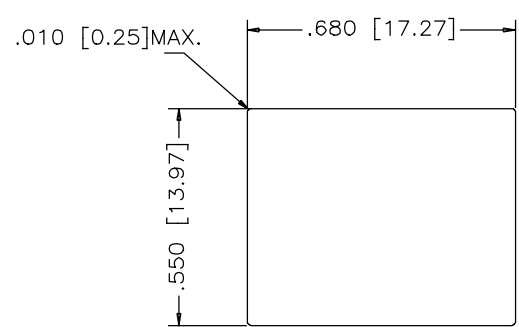
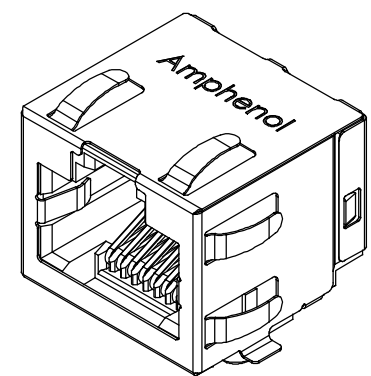
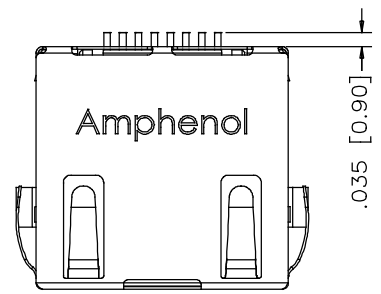
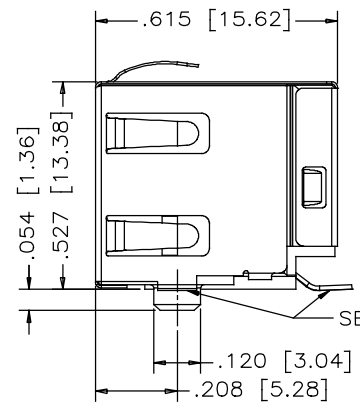
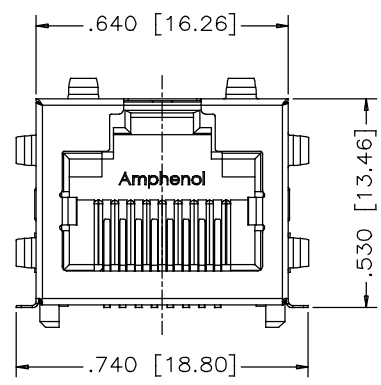

SEE NOTE 2



- 1, MATERIALS:
- HOUSING: HIGH TEMPERATURE THERMOPLASTIC
FLAMMABILITY RATING UL 94V-0
COLOR: BLACK
 - CONTACTS: PHOSPHOR BRONZE
 - PLATING: GOLD PLATING ON MATING SURFACE REFER TO AMPHENOL PART SYSTEM.
50 u" [1.27 MICRONS] MIN NICKEL UNDERPLATE.
100 u" [2.54 MICRONS] MIN MATTE-TIN OR GOLD FLASH ON CONTACT TAILS.
 - SHIELD: STAINLESS STEEL WITH MATTE TIN PLATING.

2, COPLANARITY SPECIFICATION:
THE MAXIMUM GAP BETWEEN ALL TERMINAL TAILS IS 0.10 [0.004]

PART NUMBER: RJCSE-X380-01
GOLD PLATING OPTION
2 = 6u" 4 = 30u"
3 = 15u" 5 = 50u"

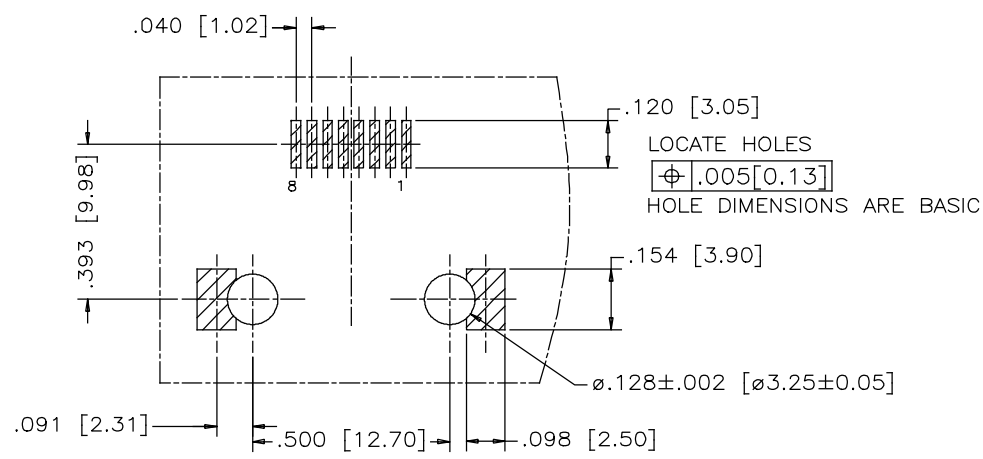

RECOMMENDED P.C.B. LAYOUT
(COMPONENT SIDE OF BOARD)

THIS DOCUMENT CONTAINS PROPRIETARY INFORMATION AND SUCH INFORMATION MAY NOT BE DISCLOSED TO OTHERS FOR ANY PURPOSE OR USED FOR MANUFACTURING PURPOSES WITHOUT WRITTEN PERMISSION FROM AMPHENOL CANADA CORP.

UNLESS SPECIFIED OTHERWISE		DRAWN	RONNIE.C	SEP 26/17	Amphenol Canada Corp. www.amphenolcanada.com
PRIMARY UNITS	INCHES	CHECKED	AMY.Z	SEP 26/17	
SECONDARY	MILLIMETERS	M.E. APP'D			TITLE
REFERENCE IN PARENTHESES		Q.A. APP'D			SINGLE PORT SURFACE MOUNT JACK 8 POSITION, 8 CONTACTS, SHIELDED, WITHOUT LED- RoHS COMPLIANT
		DWG APP'D			DWG NO.
1 DECIMAL PLACE		ENG. REL. NO.			P-RJCSE-X380-01
2 DECIMAL PLACES		REF.	EAR# RJ17176		REV
3 DECIMAL PLACES ±0.015		THIRD ANGLE PROJECTION			A
ANGULAR DEGREES		DO NOT SCALE DRAWING			CODE ID NO. 03554 DWG SIZE SCALE SHEET 1 OF 2

REVISIONS			
REV	DESCRIPTION, ECN, EAR NO.	DATE	APP'D
A	PROPOSAL	SEP 26/17	L.CHAN

← DIRECTION OF CONNECTOR LOADED INTO MACHINE.
LEADS FACING FRONT SIDE

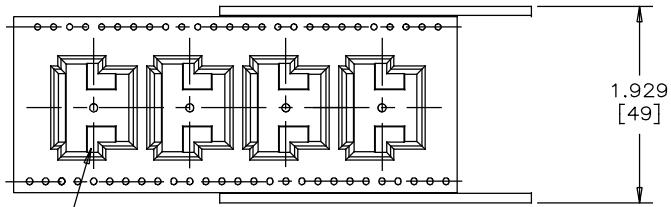

TOP VIEW
(COVER TAPE NOT SHOWN)

SEE DETAIL 'A'

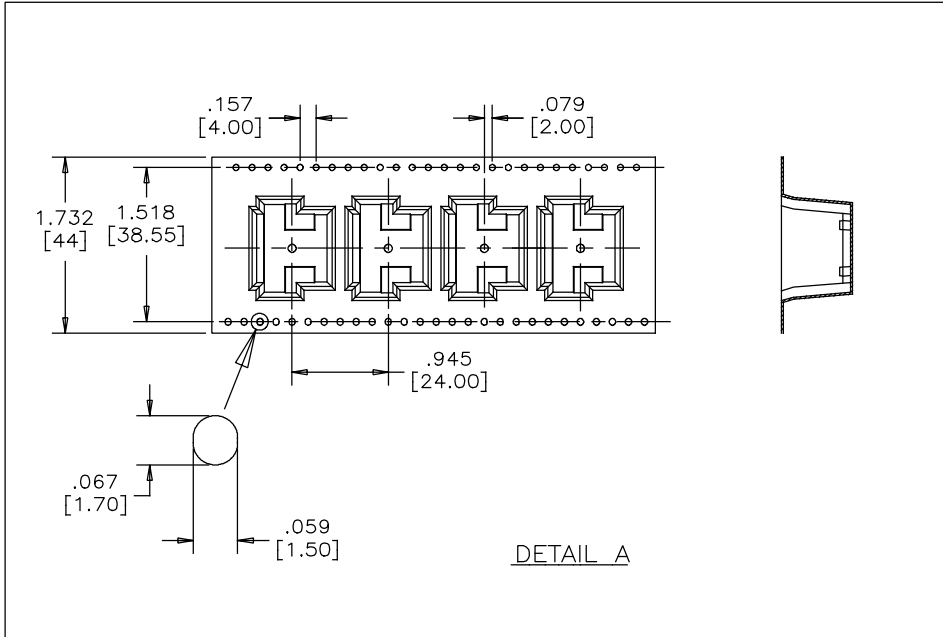

DETAIL A

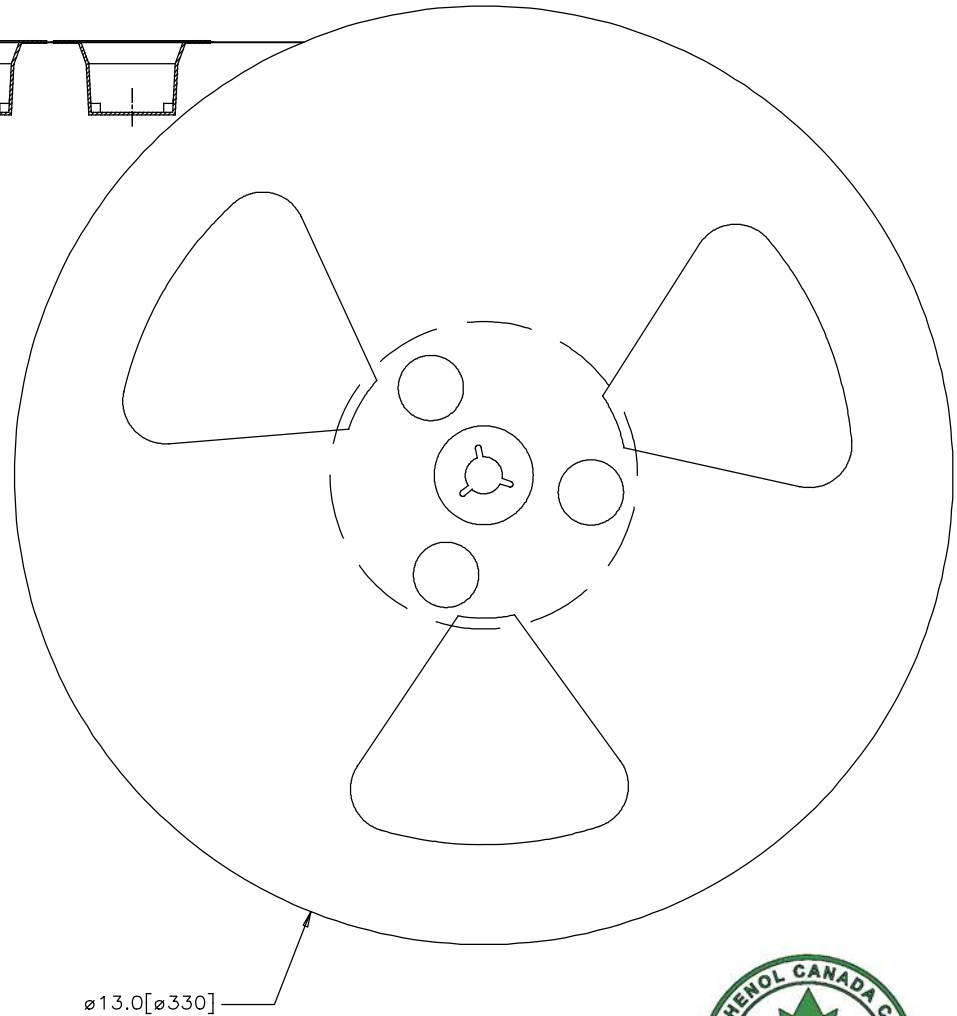
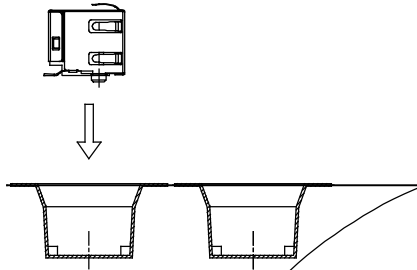

ø13.0[ø330]



PACKAGING NOTES:

1. ONE REEL SHOULD HOLD 150 CONNECTORS.
2. 15 EMPTY CAVITIES FOR CARRIER TAPE LEADER & 7 EMPTY CAVITIES FOR CARRIER TAPE TRAILER.
3. A FULLY LOADED CARTON SHOULD CONTAIN 5 REELS OF CONNECTORS.

THIS DOCUMENT CONTAINS PROPRIETARY INFORMATION AND SUCH INFORMATION MAY NOT BE DISCLOSED TO OTHERS FOR ANY PURPOSE OR USED FOR MANUFACTURING PURPOSES WITHOUT WRITTEN PERMISSION FROM AMPHENOL CANADA CORP.

UNLESS SPECIFIED OTHERWISE	DRAWN	RONNIE.C	SEP 26/17
PRIMARY UNITS INCHES	CHECKED	AMY.Z	SEP 26/17
SECONDARY MILLIMETERS	M.E. APP'D		
REFERENCE IN PARENTHESES	Q.A. APP'D		
	DWG APP'D		
	ENG. REL. NO.		
1 DECIMAL PLACE	REF.	EAR# RJ17176	
2 DECIMAL PLACES			
3 DECIMAL PLACES ±0.015			
ANGULAR DEGREES ±1.5°			
	THIRD ANGLE PROJECTION		
	DO NOT SCALE DRAWING		

Amphenol Canada Corp. www.amphenolcanada.com	
TITLE SINGLE PORT SURFACE MOUNT JACK 8 POSITION, 8 CONTACTS, SHIELDED, WITHOUT LED- RoHS COMPLIANT	
DWG NO.	P-RJCSE-X380-01
CODE ID NO. 03554	DWG SIZE SCALE SHEET 2 OF 2

REV A