



Latching Relay with Intrinsically Safe Outputs



Specifications

Electrical

Supply Voltage: 12 or 24 AC/DC $\pm 10\%$
Power: 0.8 watts
Inputs: Switch Closure or Probe
Input Sensitivity: 10k - 100k Ω
Pick-up & Drop-out Delays: 1 second
Max. Open Circuit Voltage: 5.9 volts DC
Max. Source Current: 0.1 milliamps
Output Rating @ 25°C:
 5 Amps @ 125VAC
 5 Amps @ 30VDC or 250VAC
 20,000,000 Mechanical Cycles

Physical

Mounting: Din Rail mount
Termination: Touch safe screw terminals, with lift mechanism, #12 AWG max.
Weight: 10 Oz.

Ambient Temperatures

Operating: 0°C to 55°C
Storage: -40°C to 85°C

UL-913 / CSA 157

Associated apparatus providing intrinsically safe outputs for use in Class I, Division 1, Groups A, B, C, & D Class II, Groups E, F & G, Class III



Ordering Information

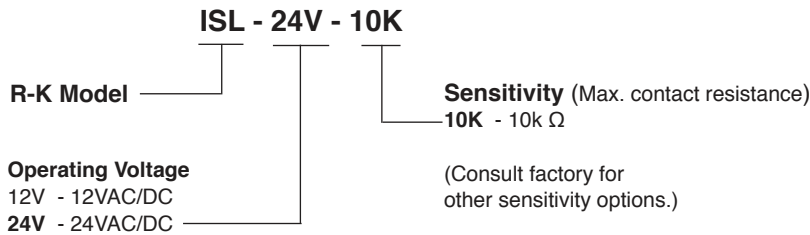

- Two Inputs - Latching Function
- Compact Design
- Contact or Probe Input
- Built-in De-bounce Delays
- Output and Input status LEDs
- Low Voltage Design for 12 or 24VAC/DC
- Din Mounting
- 12 or 24VDC Battery Back-Up

Connections

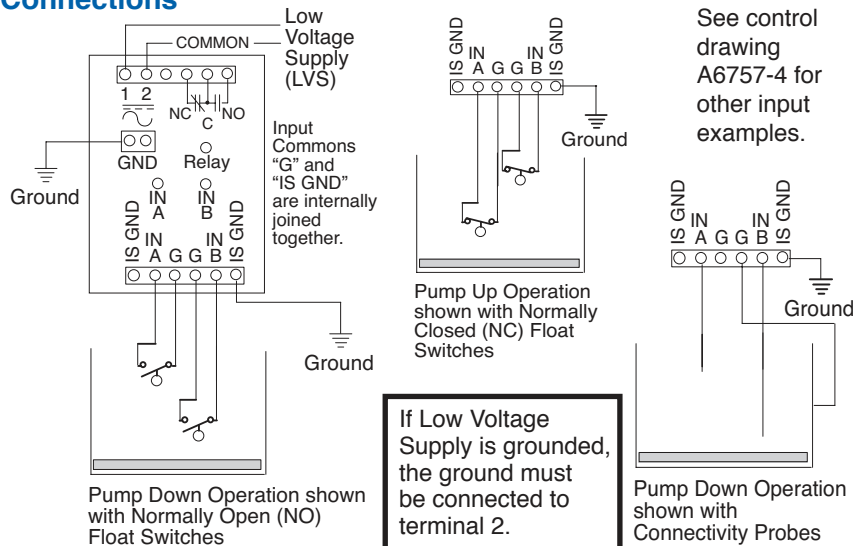

E199046
Standard UL 913 / CSA 157

Operation

Latching Relay

The ISL has two independent outputs to the hazardous area and one (dry contact) relay output with a latching function. The outputs can be switches (float or pressure) or, when used with a conductive liquid, electrodes. Pump Down Operation: When output "B" is completed (contact closed or low resistance), 1 second later LED "B" lights but there is no change in the relay output contacts. and the dry output contact is energized. When output "A" is completed, LED "A" lights and the output relay is energized. When output "A" opens, there is no change in the output contact. When output "B" opens, the output relay is de-energized. Pump Up Operation: Use normally closed input devices and reverse the positions of "A" and "B" outputs.

Dimensions

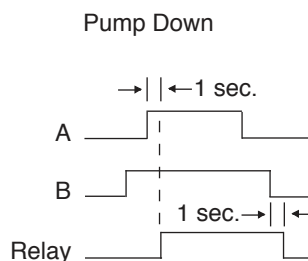
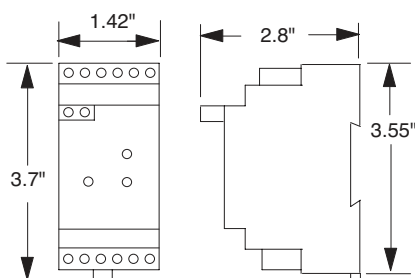

Installation of Relays with Intrinsically Safe Outputs



Installation of these relays should only be performed by personnel experienced with intrinsically safe devices. Proper wiring practices must be strictly adhered to in order to prevent injury to personnel and property damage due to explosion or fire.

IMPORTANT: BEFORE PROCEEDING TO INSTALL AND WIRE THE RELAY, READ AND THOROUGHLY UNDERSTAND THESE INSTRUCTIONS.

When installed according to the following instructions and Control Drawing A-6757-4 these Relays providing intrinsically safe outputs are for use in Class I, Division 1, Groups A, B, C, & D: Class II, Groups E, F & G, Class III. The relay must be mounted in a suitable enclosure which is tool accessible and is situated in a non hazardous area where an explosive atmosphere will not exist at any time.

Wiring:

- All intrinsically safe wiring should be installed in accordance with NEC NFPA 70 Article 504 and ISA RP 12.6 and CEC Section 18.
- Electrical equipment connected to the non intrinsically safe side should not use or be capable of generating more than 250 volts with respect to earth.
- Intrinsically safe wiring connecting to the relay must be kept separate from non-intrinsically safe wiring by means of physical barriers and wiring tie down devices to insure no contact.
- The cabinet must have a proper earth ground and the relay must be grounded. At least one ground from the intrinsically safe side and the non intrinsically safe side of relay must be made using #12 AWG insulated conductors. The units redundant earth ground wires must be individually connected with metal screws and lockwashers to the cabinets earth ground. Resistance between the relay ground to the grounding electrode shall be less than one ohm.
- Intrinsically safe connections must not be made to any energy generating device or device mounted inside a tank subjected to pressures greater than 15 psi without specific approval.
- Maximum distance between the input of the relay and the switch is 1000 feet. Cable capacitance plus intrinsically safe equipment capacitance must be less than the marked capacitance (C_a) shown on any barrier used. The same applies for inductance. We recommend the use of 14 AWG type THHN wire without splices. In no case should the capacitance or inductance exceed the specified limits. If the characteristics of your wire are unknown the following values may be used.

CAPACITANCE: 60 pf / ft
INDUCTANCE: 0.20 μ h / ft
- This device may be used in a Division 2. Location if so approved.
- Selected barriers must have V_{oc} not exceeding V_{max} and I_{sc} not exceeding I_{max} as shown below. All barriers must be of the same polarity.

Entity parameters:

$V_{oc} = 5.89$ Volts

$I_{sc} = 0.132$ mA

$C_a = 0.45$ μ f

$L_a = 500$ mH

$V_{oc} \leq V_{max}$

$I_{sc} \leq I_{max}$

$C_a \geq C_l + C_{cable}$

$L_a \geq L_l + L_{cable}$

