

## PRODUCT NUMBERING

10035691 X X X XX

BLANK: PLATING TIN/LEAD  
LF: PLATING LEAD FREE

2: METAL CLIP A WITH TIN AT SOLDER TAIL  
3: METAL CLIP b WITH TIN AT SOLDER TAIL  
4: METAL CLIP B WITH G/F AT SOLDER TAIL  
5: METAL CLIP C WITH TIN AT SOLDER TAIL  
6: METAL CLIP D WITH G/F AT SOLDER TAIL  
7: METAL CLIP B WITH TIN AT SOLDER TAIL  
(30μ" [0.76μm] GOLD AT CONTACT)  
S: METAL CLIP B WITH TIN AT SOLDER TAIL  
5μ" GOLD AT CONTACT

0: TUBE PACKING  
1: T&R PACKING  
2: T&R WITH CAP (NOTE 6)  
3: TRAY WITH CAP (NOTE 6)

HOUSING  
0: BLACK  
1: BLUE

### NOTES:

1. MATERIAL
  - i) HOUSING : HIGH TEMPERATURE THERMOPLASTIC UL94V-0
  - ii) TERMINAL : COPPER ALLOY
  - iii) HOLD DOWN: COPPER ALLOY
2. FINISH
  - i) TERMINAL : 15μ" MIN Au PLATING AT CONTACT POINT  
100μ" MIN PURE MATT TIN OR GOLD FLASH PLATING AT  
SOLDER TAIL WITH NICKEL UNDERPLATE
  - ii) HOLD DOWN : 100-200μ" PURE MATT TIN PLATING
3. P/N 10035691-XXXLF, THE HOUSING WILL WITHSTAND EXPOSURE TO 260°C  
PEAK TEMPERATURE FOR 10 SECONDS IN A REFLOW SOLDER APPLICATION WITH  
1.6mm MIN THICK CIRCUIT BOARD
4. PACKAGING SPEC: GS-14-840
5. PRODUCT SPEC : GS-12-194.
6. PRODUCT SPEC : 110-634 FOR 10035691-033LF, -023LF ONLY.
7. ALTERNATIVE PRODUCT SPEC. GS-12-200 (FOR CABLE APPLICATION).

Amphenol  
FCi

© 2016 AFCI

spec ref -		dr	WADE LIU	2005-09-09	projection	mm	size	A3	scale	4:1	
tolerance std -		eng	WADE LIU	2005-09-09		←→	ecn no		ELX-S-29996-1		
TOLERANCES UNLESS OTHERWISE SPECIFIED		chr	WADE LIU	2005-09-09			rel level		Released		
surface -	linear ✓	0.X	±0.30	<b>Amphenol FCi</b>	S-ATA SIGNAL PLUG SMT VERTICAL TYPE ASSY		dwg no	10035691		rev	J
		0.XX	±0.20								
		0.XXX	±0.10								
-	angular	0°	±2°	cat. no.	-	Product - Customer Drw		sheet 1 of 3			

Amphenol  
FCi

© 2016 AFCI

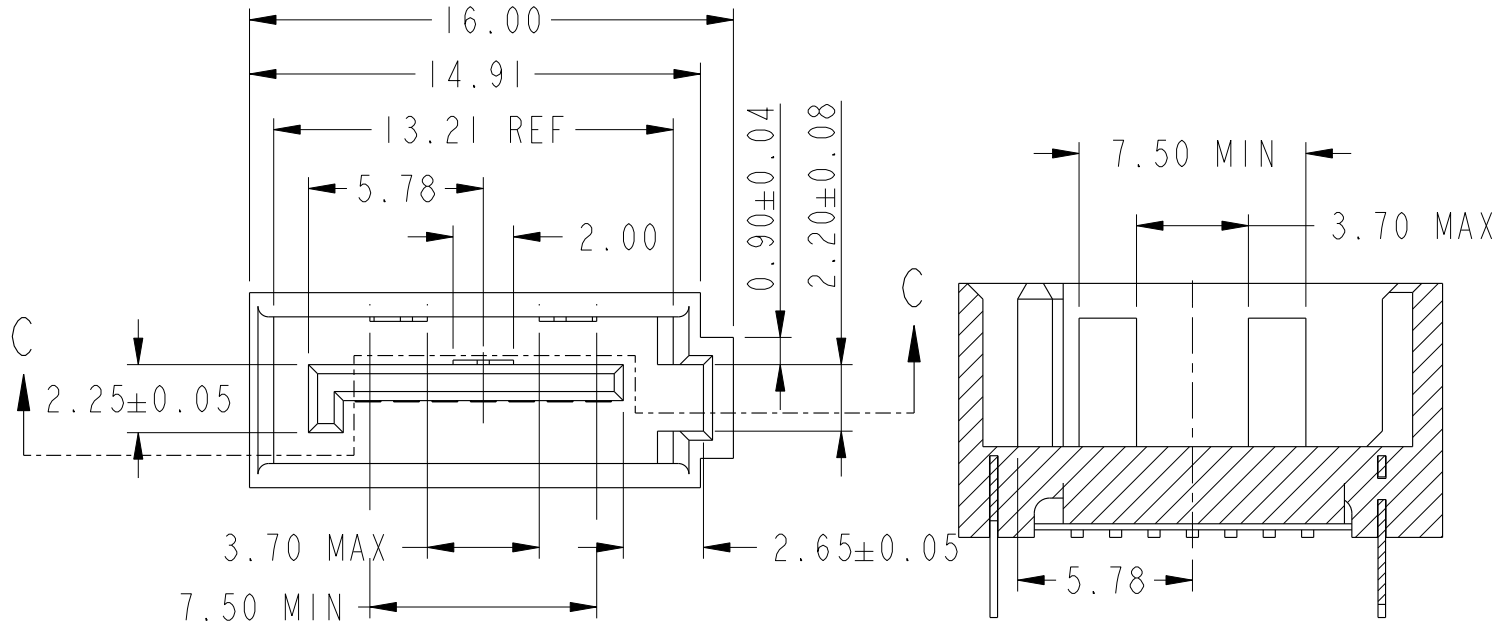

SECTION C-C

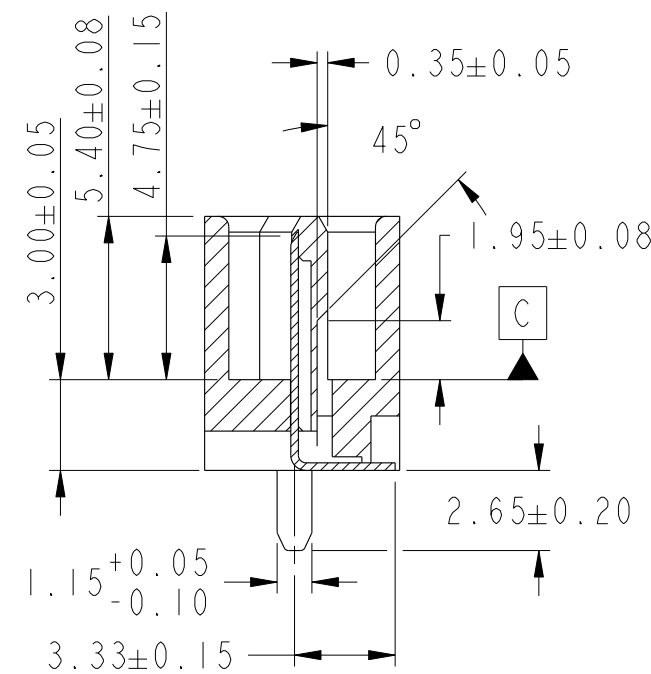

SECTION A-A  
METAL CLIP B

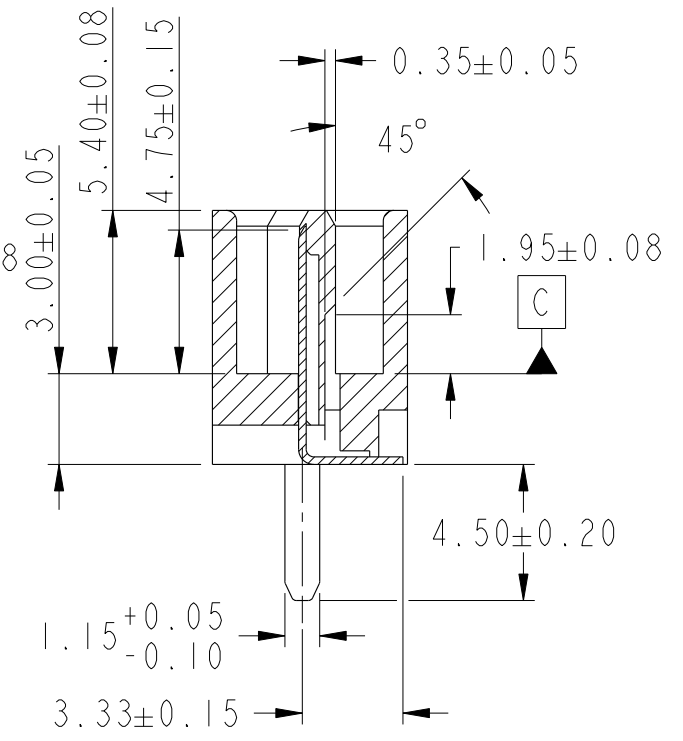

SECTION A-A  
METAL CLIP D

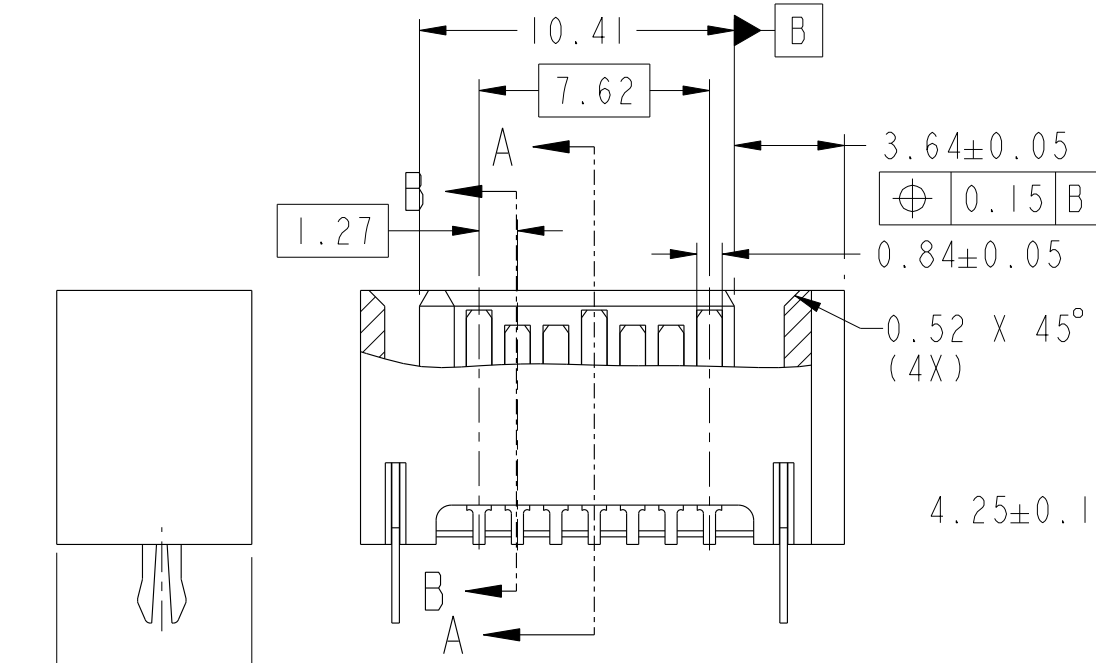

SECTION D-D

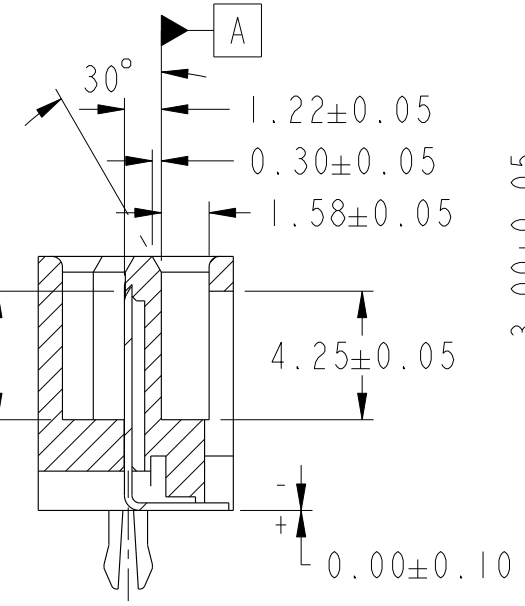

SECTION B-B

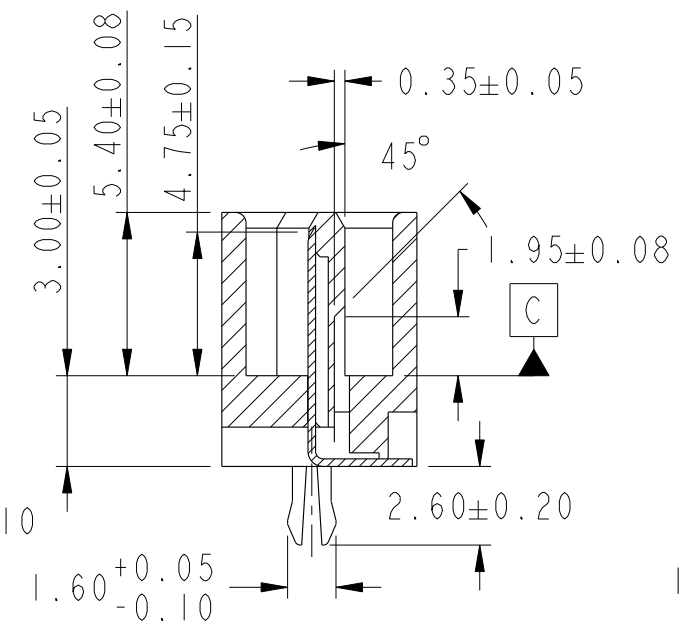

SECTION A-A  
METAL CLIP A

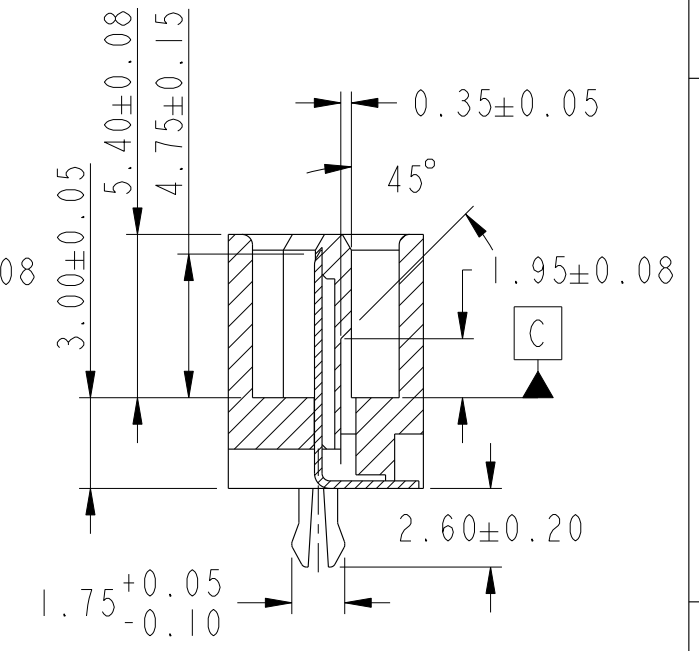

SECTION A-A  
METAL CLIP C

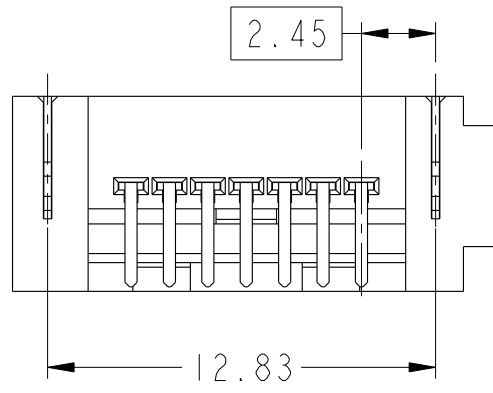

spec ref	-	dr	WADE LIU	2005-09-09	projection	mm	size	A3	scale	4:1
tolerance std	TOLERANCES UNLESS OTHERWISE SPECIFIED	eng	WADE LIU	2005-09-09			ecn no	ELX-S-29996-1	rel level	Released
-		chr	WADE LIU	2005-09-09						
surface	linear	0.X	±0.30	<b>Amphenol FCi</b>	title S-ATA SIGNAL PLUG SMT VERTICAL TYPE ASSY	cat. no. -	dwg no 10035691	rev J	Product - Customer Drw	sheet 2 of 3
-		0.XX	±0.20							
-	angular	0°	±2°							

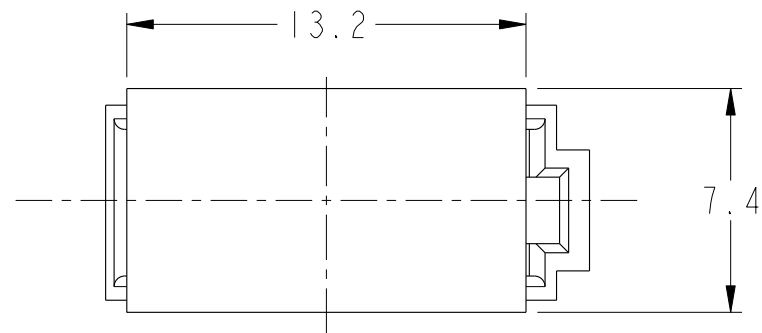

PRODUCT WITH CAP FOR T & R PACKING

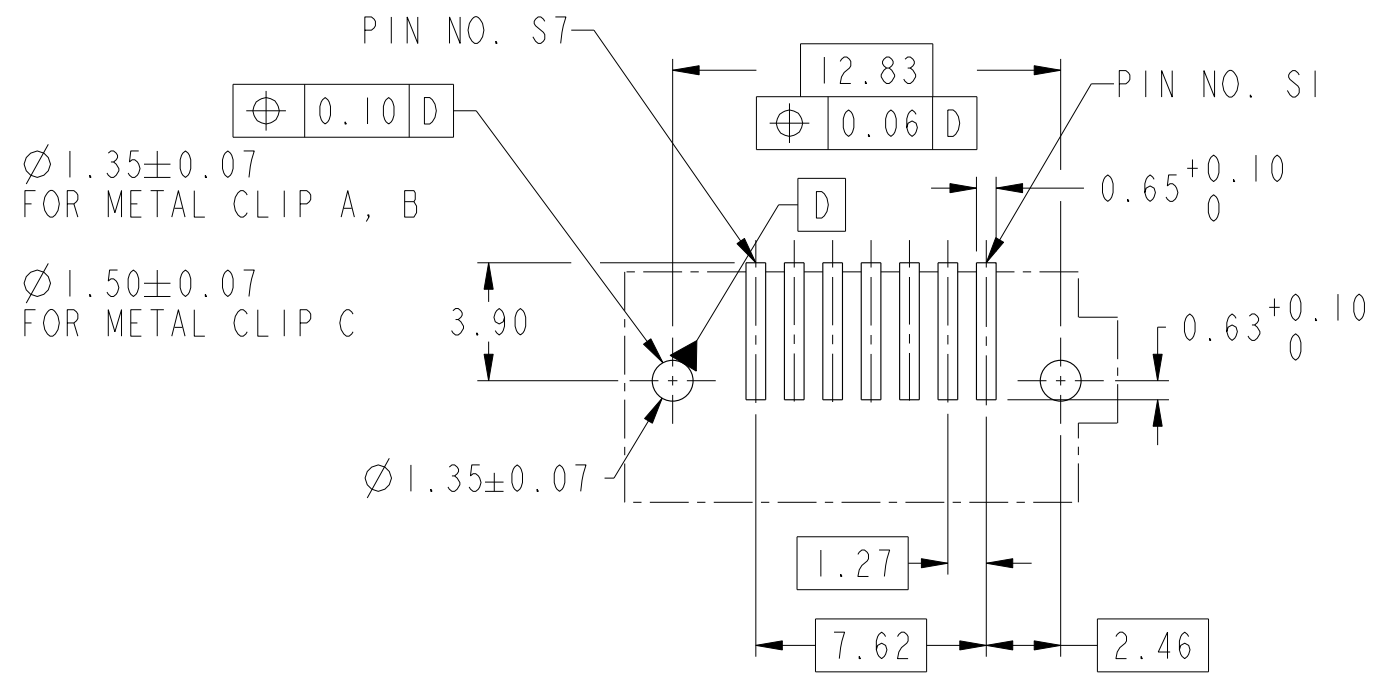
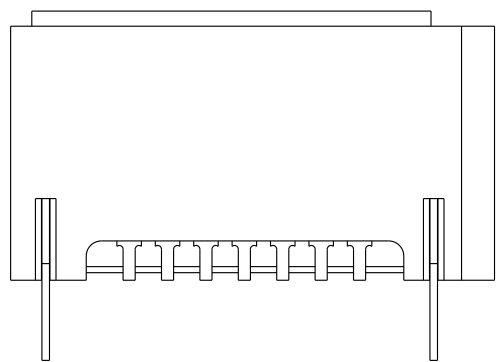

RECOMMENDED MOUNTING LAYOUT  
 RECOMMENDED PCB T = 1.60mm  
 TOLERANCE UNLESS OTHERWISE :  $\pm 0.1$

Amphenol  
FCi

© 2016 AFCI

spec ref	-	dr	WADE LIU	2005-09-09	projection		size	A3	scale	4:1		
tolerance std	TOLERANCES UNLESS OTHERWISE SPECIFIED	eng	WADE LIU	2005-09-09		mm	ecn no	ELX-S-29996-1				
-		chr	WADE LIU	2005-09-09				product family	rel level	Released		
-		appr	STERLING LIN	2005-09-09								
surface	linear		Amphenol FCi	S-ATA SIGNAL PLUG SMT VERTICAL TYPE ASSY	cat. no.	-	Product - Customer Drw	sheet 3 of 3	dwg no	10035691	rev	J
	angular									0°	$\pm 2^\circ$	