

Ten LVCMOS Output Low Additive Jitter Fanout Buffer

Features

- 3 to 1 input Multiplexer: Two inputs accept any differential (LVPECL, HCSSL, LVDS, SSTL, CML, LVCMOS) or a single ended signal and the third input accepts a crystal or a single ended signal
- Ten 1.5V/1.8V/2.5V/3.3V LVCMOS outputs
- Supports frequencies from 0 to 200MHz
- Supports crystals from 8MHz to 60MHz
- Ultra-low additive jitter: 17fs (12kHz to 20MHz)
- Ultra-low noise floor of -170dBc/Hz
- Supports 2.5V or 3.3V power supplies
- Output to output skew of 30ps (typical)
- Input to output delay of 2ns (typical)

Ordering Information

ZL40241LDG1	32 Pin QFN	Trays
ZL40241LDF1	32 pin QFN	Tape and Reel
Package size: 5 x 5 mm		
-40°C to +85°C		

Applications

- General purpose clock distribution
- Low jitter clock trees
- Logic translation
- Clock and data signal restoration
- Wired and Wireless communications
- High performance microprocessor clock distribution
- Medical Imaging
- Test equipment

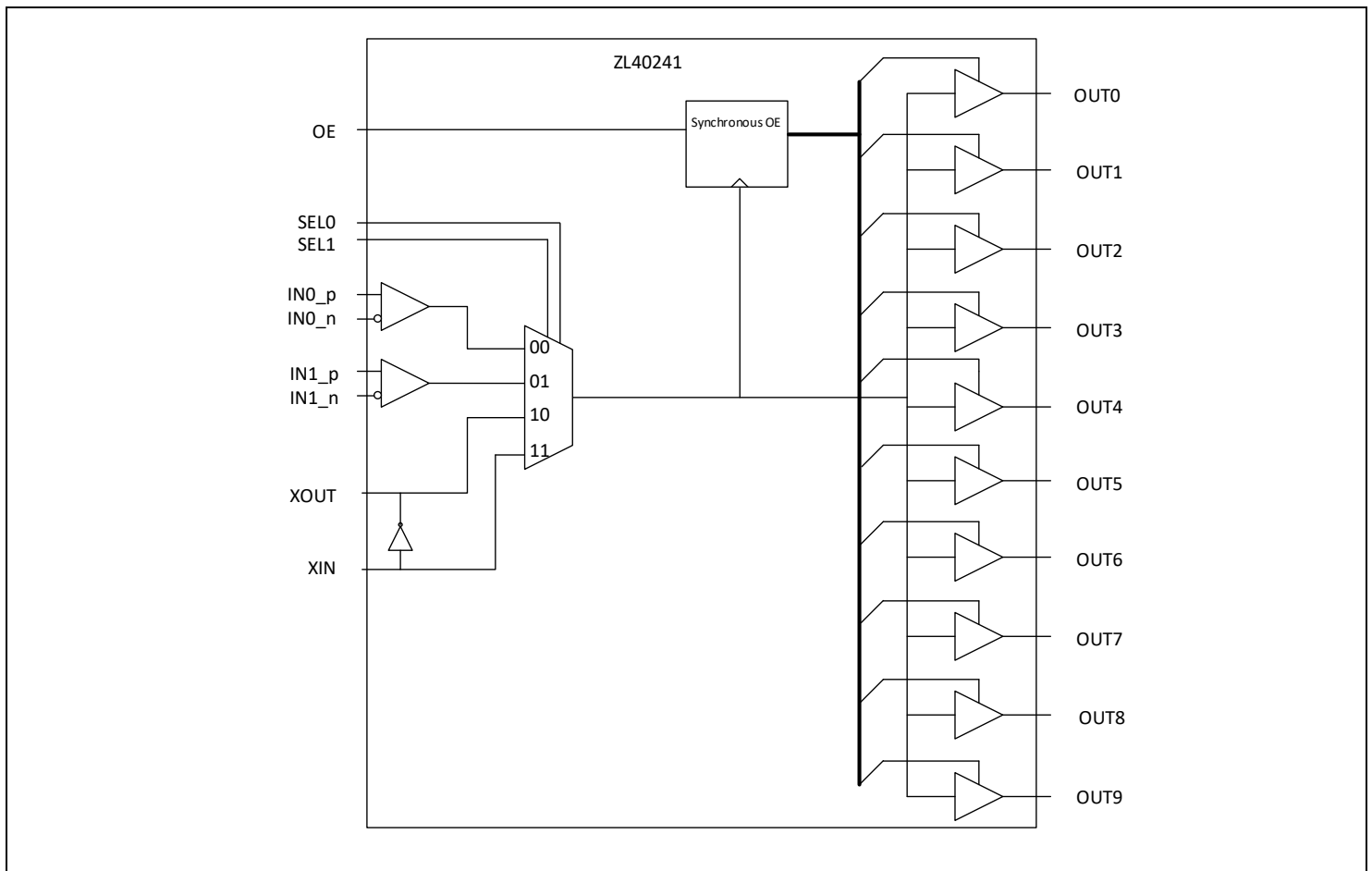

Figure 1. Functional Block Diagram

Table of Contents

Features	1
Table of Contents	2
Pin Diagram	5
Pin Descriptions	6
Functional Description	8
Clock Inputs	8
Clock Outputs	11
Crystal Oscillator Input.....	11
Termination of unused inputs and outputs	12
Power Consumption	13
Power Supply Filtering.....	15
Device Control	15
AC and DC Electrical Characteristics	16
Absolute Maximum Ratings.....	16
Recommended Operating Conditions	16
Package Outline	21
Revision History.....	22

List of Figures

Figure 1.	Functional Block Diagram.....	1
Figure 2.	Pin Diagram	5
Figure 3.	Input driven by a single ended output	8
Figure 4.	Input driven by DC coupled LVPEVCL output	8
Figure 5.	Input driven by DC coupled LVPEVCL output (alternative termination).....	9
Figure 6.	Input driven by AC coupled LVPECL output.....	9
Figure 7.	Input driven by HCSL output	9
Figure 8.	Input driven by LVDS output	10
Figure 9.	Input driven by AC coupled LVDS.....	10
Figure 10.	Input driven by an SSTL output	10
Figure 11.	Termination for 3.3V LVPECL outputs.....	11
Figure 12.	Crystal Oscillator Circuit.....	11
Figure 13.	Phase Noise Plot with 25MHz Crystal	12
Figure 14.	Device power consumption per output for $V_{DD} = V_{DDO} = 3.465V$	13
Figure 15.	Device power consumption per output for $V_{DD} = V_{DDO} = 2.625V$	14
Figure 16.	Dynamic supply current per output for different output supply voltages	14
Figure 17.	Power Supply Filtering	15

List of Tables

Table 1 · Pin Descriptions	6
Table 2 · Absolute Maximum Ratings*	16
Table 3 · Recommended Operating Conditions*	16
Table 4 · Current consumption	16
Table 5 · Input Characteristics*	17
Table 6 · Crystal Oscillator Characteristics*	17
Table 7 · LVCMOS Output Characteristics*	18
Table 8 · LVCMOS Output Additive Jitter and Phase Noise*	19
Table 9 · LVCMOS Output Jitter Phase Noise with 25MHz XTAL*	20
Table 10 · 5x5mm QFN Package Thermal Properties	20

Pin Diagram

The device is packaged in a 5x5mm 32-pin QFN.

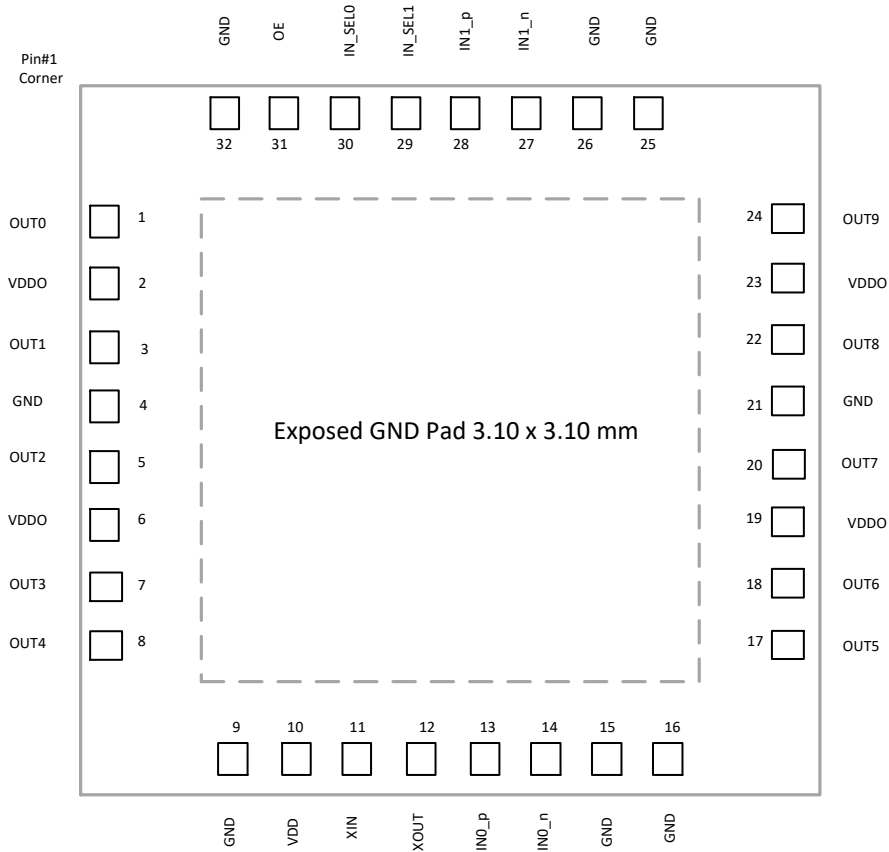

Figure 2. Pin Diagram

Pin Descriptions

All device inputs and outputs are LVPECL unless described otherwise. The I/O column uses the following symbols: I – input, I_{PU} – input with 300kΩ internal pull-up resistor, I_{PD} – input with 300kΩ internal pull-down resistor, I_{APU} – input with 30kΩ internal pull-up resistor, I_{APD} – input with 30kΩ internal pull-down resistor, I_{APU/APD} – input biased at VDD/2 with 60kΩ internal pull-up and 60kΩ pull-down resistors, O – output, I/O – Input/Output pin, P – power supply pin.

Table 1 · Pin Descriptions

#	Name	I/O	Description															
Input Reference																		
13 14 28 27	IN0_p IN0_n IN1_p IN1_n	I _{APD} I _{APU/APD} I _{APD} I _{APU/APD}	<p>Input Differential or Single Ended References 0 and 1</p> <p>Input frequency range 0Hz to 200MHz.</p> <p>Non-inverting inputs (_p) are pulled down with internal 30kΩ pull-down resistors. Inverting inputs (_n) are biased at VDD/2 with 60kΩ pull-up and pull-down resistors to keep inverting input voltages at VDD/2 when inverting inputs are left floating (device fed with a single ended reference).</p>															
Output Clocks																		
1 3 5 7 8 17 18 20 22 24	OUT0 OUT1 OUT2 OUT3 OUT4 OUT5 OUT6 OUT7 OUT8 OUT9	O	<p>Ultra-Low Additive Jitter LVCMOS Outputs 0 to 9</p> <p>Output frequency range 0 to 200MHz</p>															
Control																		
30 29	IN_SEL0 IN_SEL1	I _{PD}	<p>Input select pins. Logic level on these pins selects which input will be passed to the output.</p> <table border="1"> <thead> <tr> <th>IN_SEL1</th> <th>IN_SEL0</th> <th>OUTN</th> </tr> </thead> <tbody> <tr> <td>0</td> <td>0</td> <td>Input 0 (IN0)</td> </tr> <tr> <td>0</td> <td>1</td> <td>Input 1 (IN1)</td> </tr> <tr> <td>1</td> <td>0</td> <td>Crystal Oscillator or overdrive</td> </tr> <tr> <td>1</td> <td>1</td> <td>Crystal Bypass</td> </tr> </tbody> </table>	IN_SEL1	IN_SEL0	OUTN	0	0	Input 0 (IN0)	0	1	Input 1 (IN1)	1	0	Crystal Oscillator or overdrive	1	1	Crystal Bypass
IN_SEL1	IN_SEL0	OUTN																
0	0	Input 0 (IN0)																
0	1	Input 1 (IN1)																
1	0	Crystal Oscillator or overdrive																
1	1	Crystal Bypass																

31	OE	I _{PD}	Output Enable When high outputs are enabled. When low outputs are high-Z.
Crystal Oscillator			
11	XIN	I	Crystal Oscillator Input or crystal bypass mode or crystal overdrive mode If crystal oscillator is not used pull down this pin or connect it to ground.
12	XOUT	O	Crystal Oscillator Output
Power and Ground			
10	VDD	P	Positive Supply Voltage. Connect to 3.3V or 2.5V supply. VDD voltage must be higher or equal to VDDO.
2 6 19 23	VDDO	P	Positive Supply Voltage for LVC MOS Outputs Connect 3.3V, 2.5V, 1.8V or 1.5V power supply
4 9 15 16 21 25 26 32	GND	P	Ground Connect to ground
E-Pad	GND	P	Ground. Connect to ground

Functional Description

The ZL40241 is a pin controlled low additive jitter, low power 3 x 10 LVCMOS fanout buffer.

Two inputs can accept signal in differential (LVPECL, SSTL, LVDS, HSTL, CML) or single ended (LVPECL or LVCMOS) format and the third input can accept a single ended signal or it can be used to build a crystal oscillator by connecting an external crystal resonator between its XIN and XOUT pins.

The ZL40241 has ten LVCMOS outputs which can be powered from 3.3V, 2.5V, 1.8V or 1.5V supply. Output can be synchronously enabled/disabled via OE pin.

The device operates from 2.5V+/-5% or 3.3V+/-5% supply. Its operation is guaranteed over the industrial temperature range -40°C to +85°C.

Clock Inputs

The following blocks diagram shows how to terminate different signals fed to the ZL40241 inputs.

Figure 3 shows how to terminate a single ended output such as LVCMOS. Ideally, resistors R1 and R2 should be 100Ω each so that the transmission line is terminated with matched impedance (50Ω). However, if the driving strength of the output driver is not sufficient resistor values should be increased

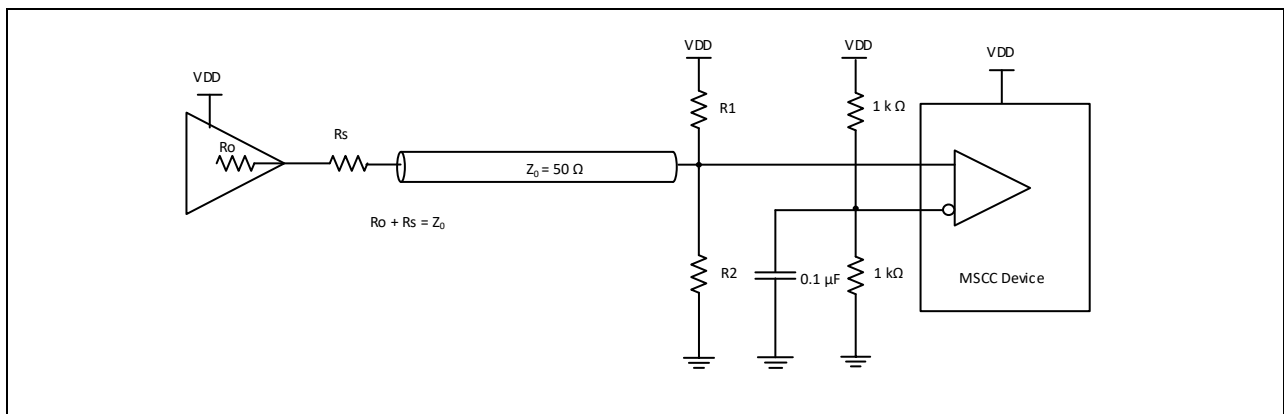

Figure 3. Input driven by a single ended output

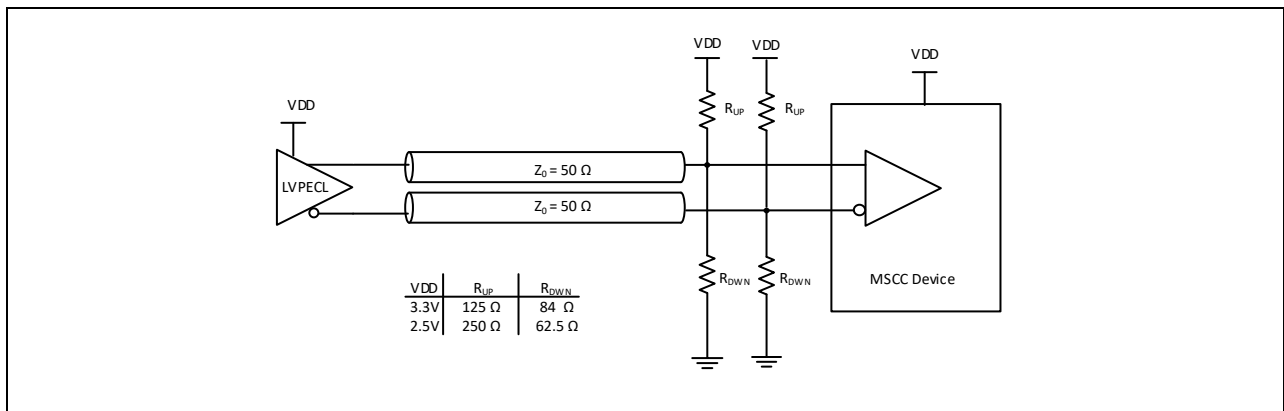

Figure 4. Input driven by DC coupled LVPEVCL output

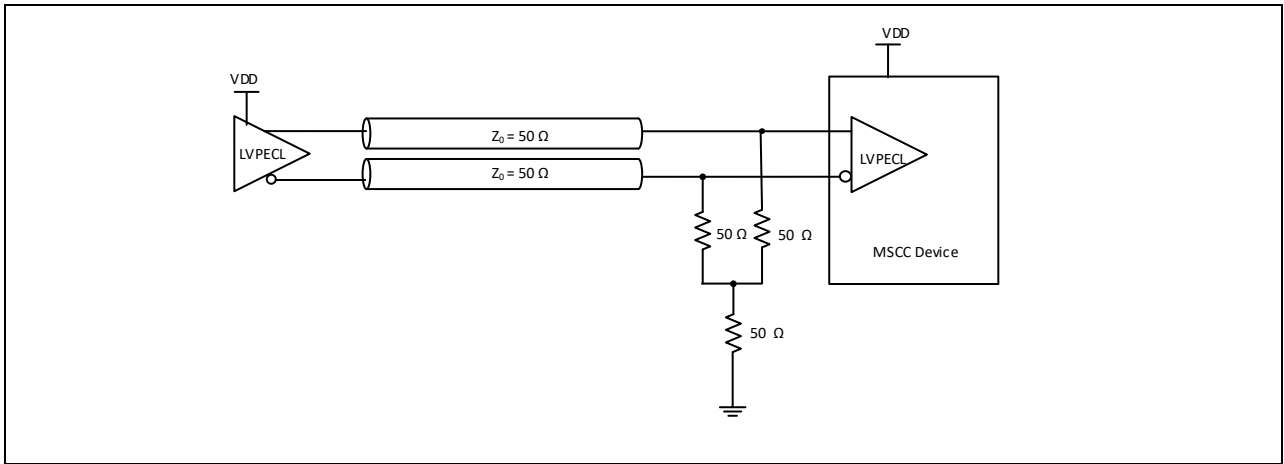

Figure 5. Input driven by DC coupled LVPEVCL output (alternative termination)

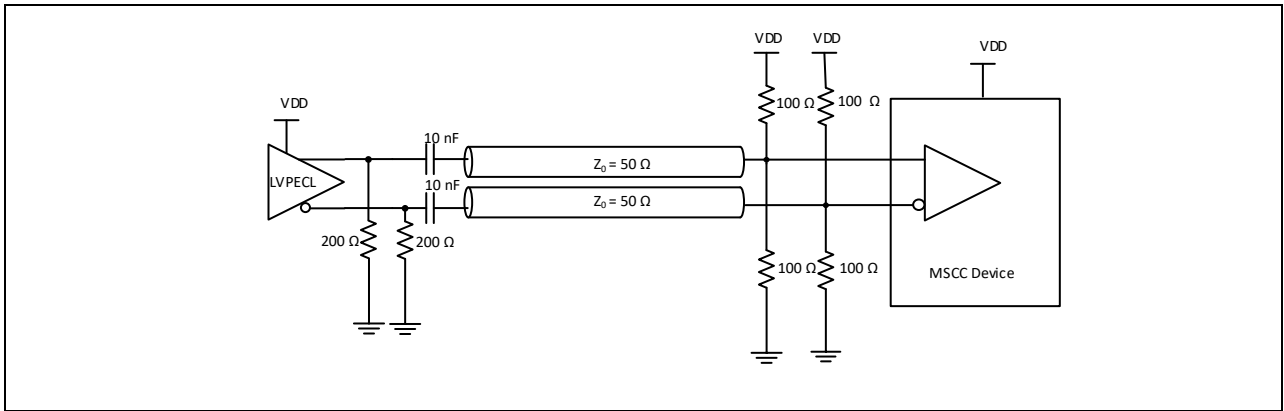

Figure 6. Input driven by AC coupled LVPECL output

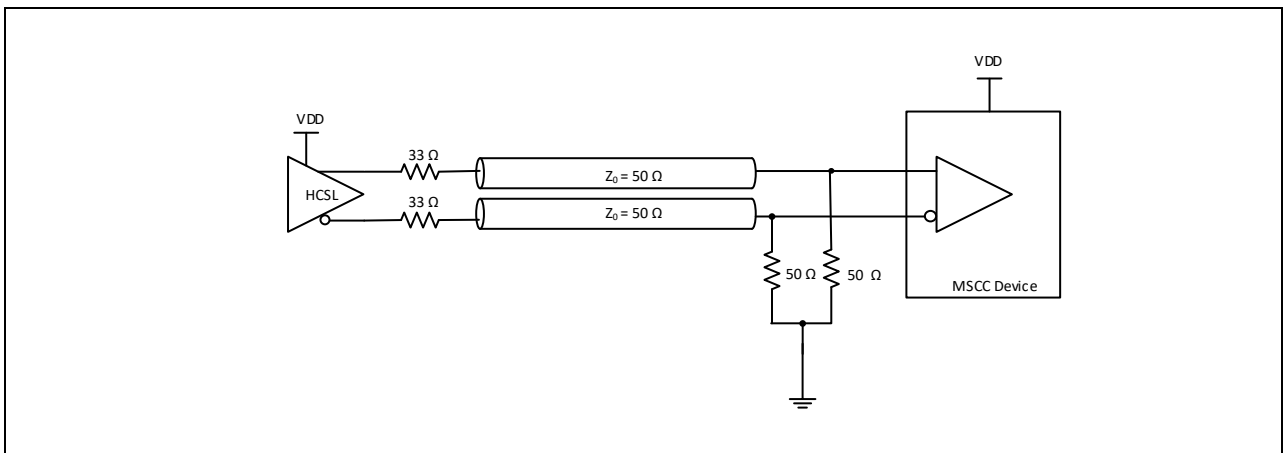

Figure 7. Input driven by HCSL output

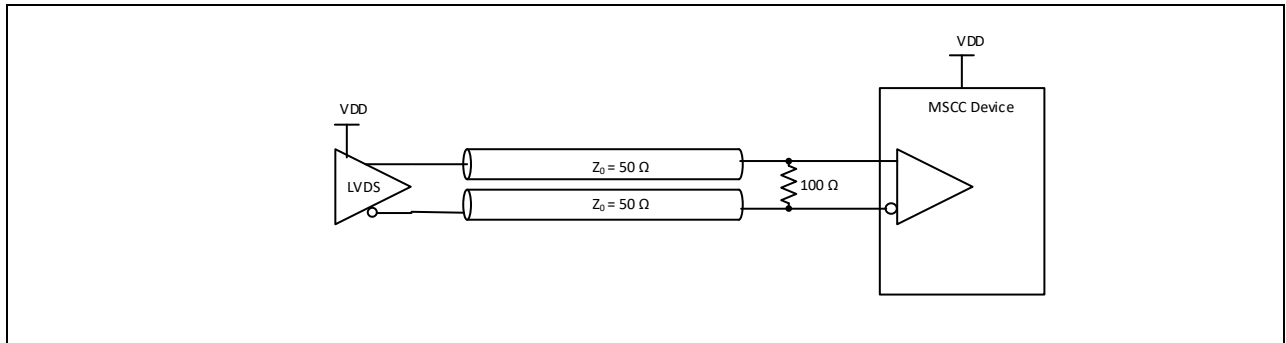

Figure 8. Input driven by LVDS output

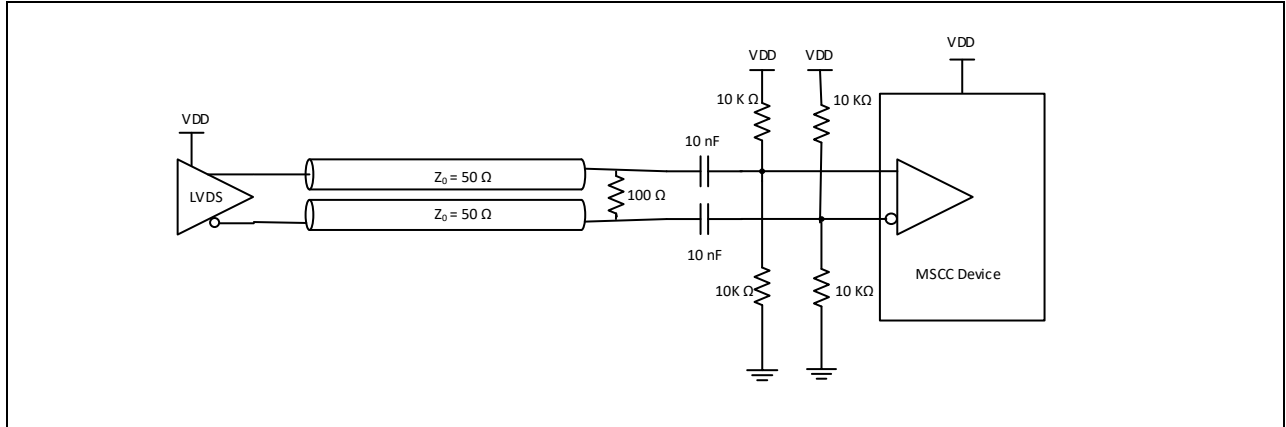

Figure 9. Input driven by AC coupled LVDS

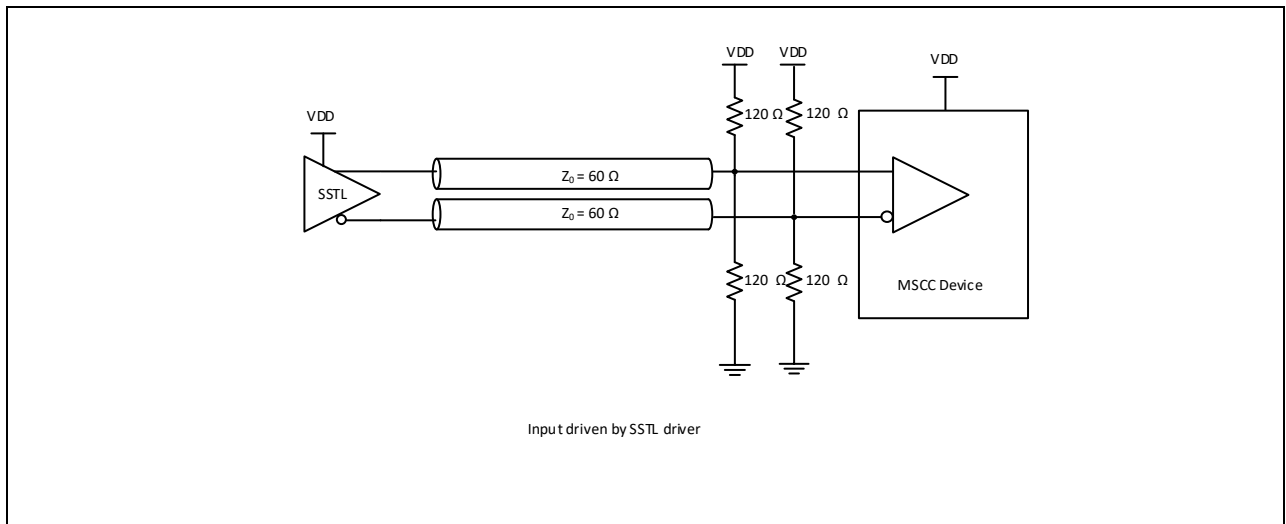

Figure 10. Input driven by an SSTL output

Clock Outputs

LVC MOS outputs require only series termination resistor whose value is depending on LVC MOS output voltage as shown in Figure 11.

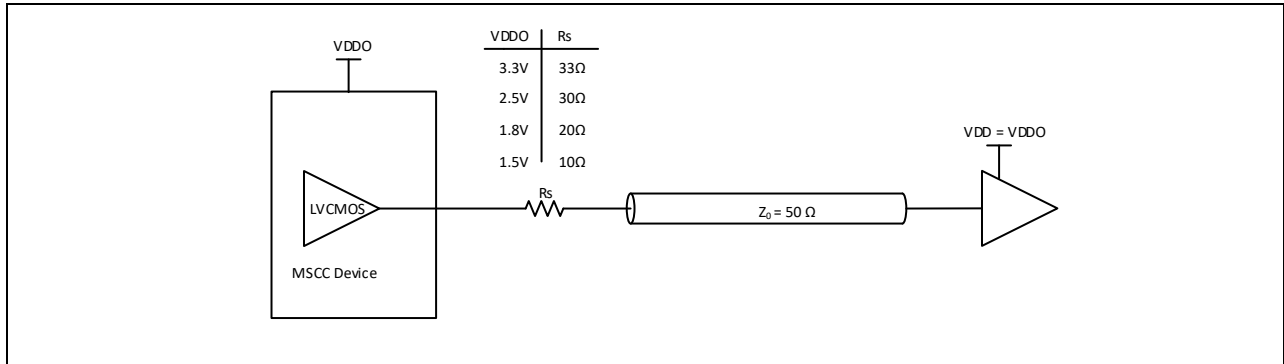

Figure 11. Termination for 3.3V LVPECL outputs

Crystal Oscillator Input

The crystal oscillator circuit can work with crystal resonators from 8MHz to 60MHz. Load capacitors C1 and C2 shall be selected as per crystal vendor recommendation. Shunt resistor is implemented inside the device. If the crystal is not used, connect XIN pin to ground.

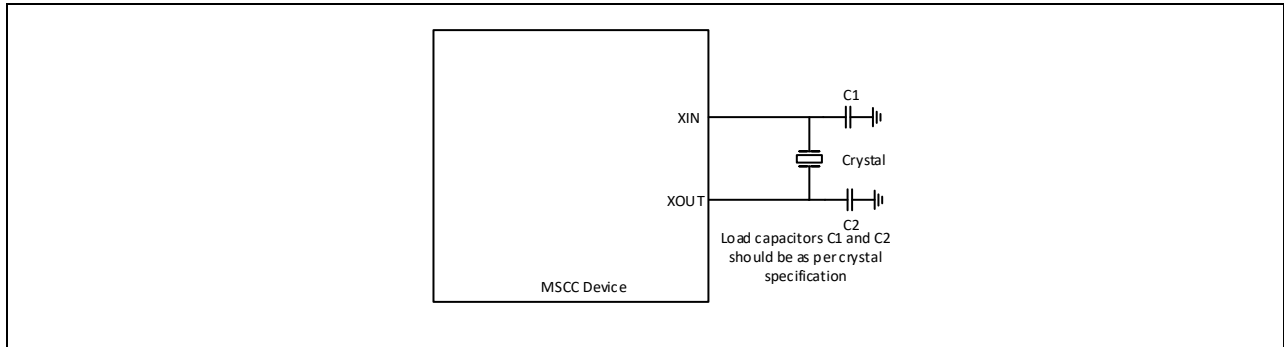

Figure 12. Crystal Oscillator Circuit

The phase noise plot for 25MHz crystal is shown in Figure 13. The phase noise floor of the device is below -170dBc/Hz as can be seen on the figure.

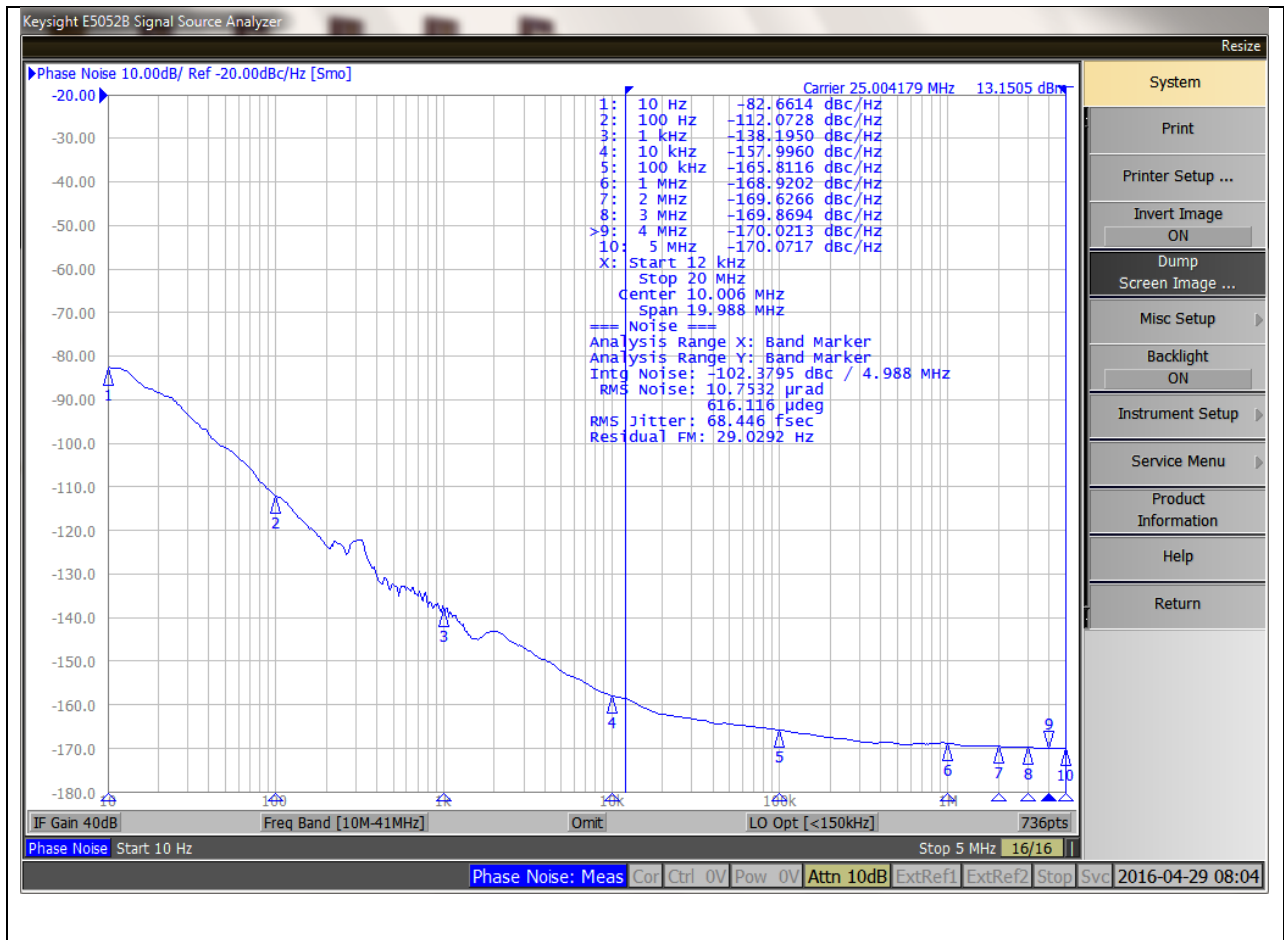

Figure 13. Phase Noise Plot with 25MHz Crystal

Termination of unused inputs and outputs

Unused inputs can be left unconnected or alternatively IN_0/1 can be pulled-down by 1kΩ resistor. Unused outputs should be left unconnected.

Power Consumption

The total device power consumption can be calculated as:

$$P_T = P_S + P_{XTAL} + P_C + P_D$$

Where:

$$P_S = V_{DD} \times I_S$$

is static power consumed by input buffers. If XTAL is running this power should be set to zero. where the static current (I_S) is specified in Table 4 .

$$P_{XTAL} = V_{DD} \times I_{DD_XTAL}$$

is power consumption of XTAL circuit. The current of the XTAL circuit is provided in Table 4 . If XTAL is not used the power consumption is equal to zero.

$$P_C = V_{DDO} \times I_{DDC}$$

Common output power shared among all ten outputs. The current (I_{DDC}) is specified in Table 4 . ,

$$P_D = V_{DDO} \times (I_{DD} \times n \times f / 100MHz + V_{DDO} \times C_{LOAD} \times f \times n)$$

Dynamic power where dynamic current (I_{DD}) is specified in Table 4 . , C_{LOAD} is capacitive load driven by an output, f is frequency of the output clock and n is number of active outputs.

The power consumption for different clock frequencies and power supply voltages can be quickly estimated from Figure 14, Figure 15 and Figure 15.

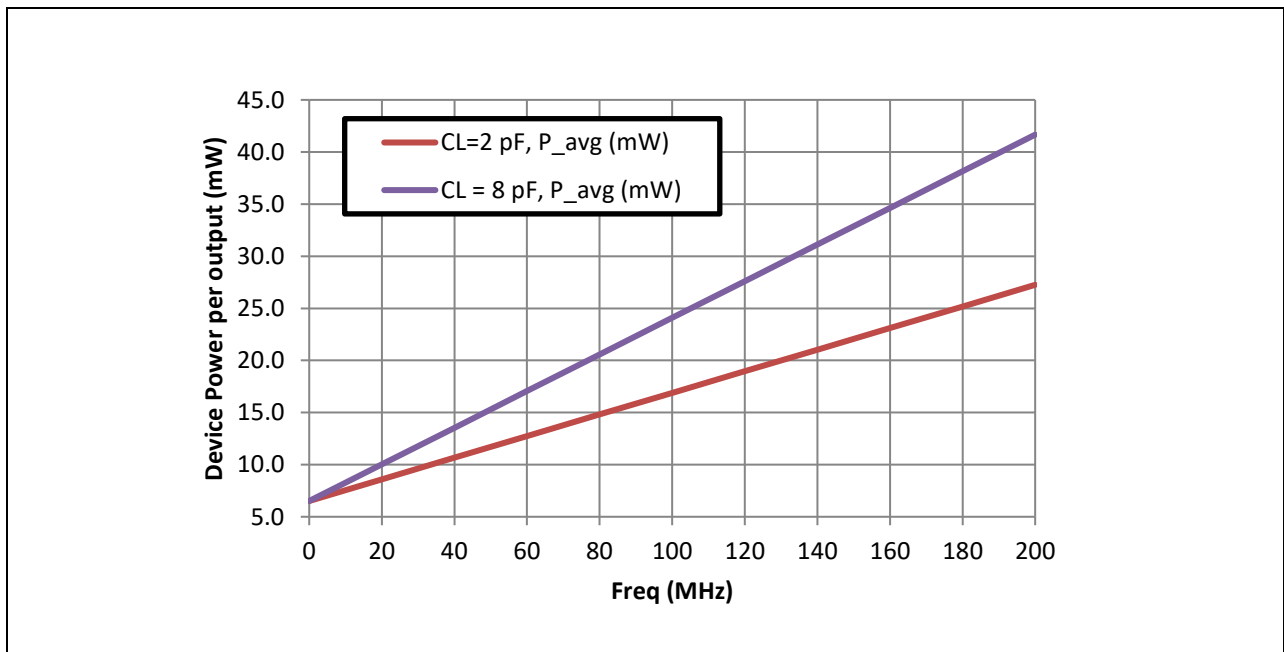

Figure 14. Device power consumption per output for $V_{DD} = V_{DDO} = 3.465V$

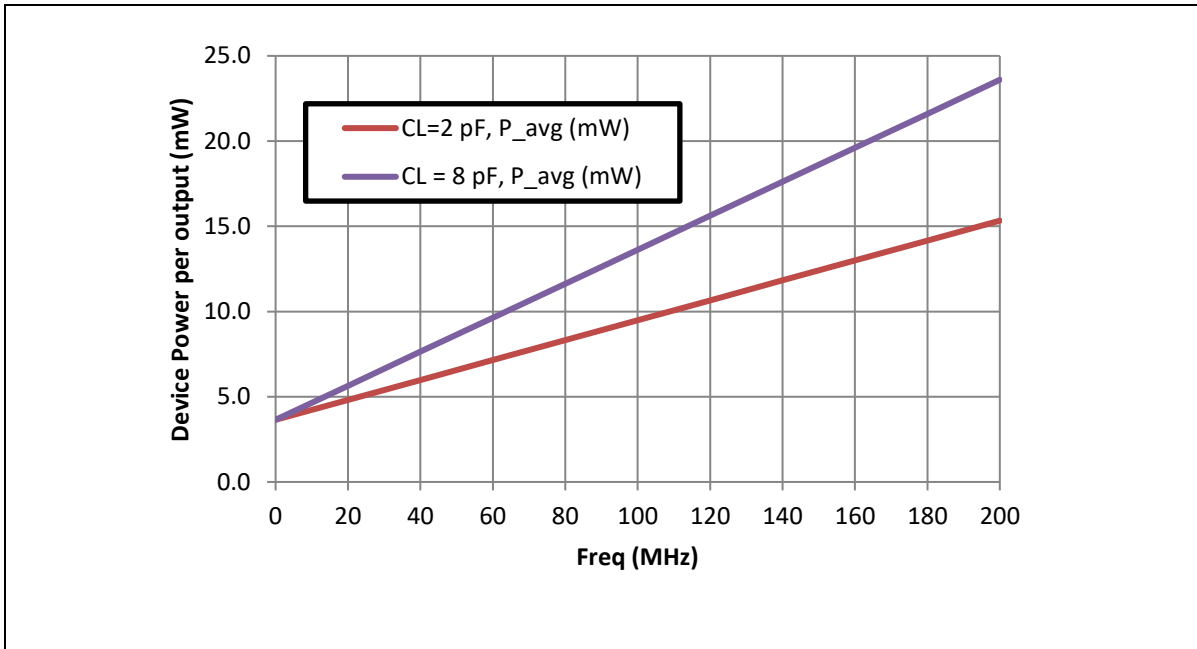

Figure 15. Device power consumption per output for $V_{DD} = V_{DDO} = 2.625V$

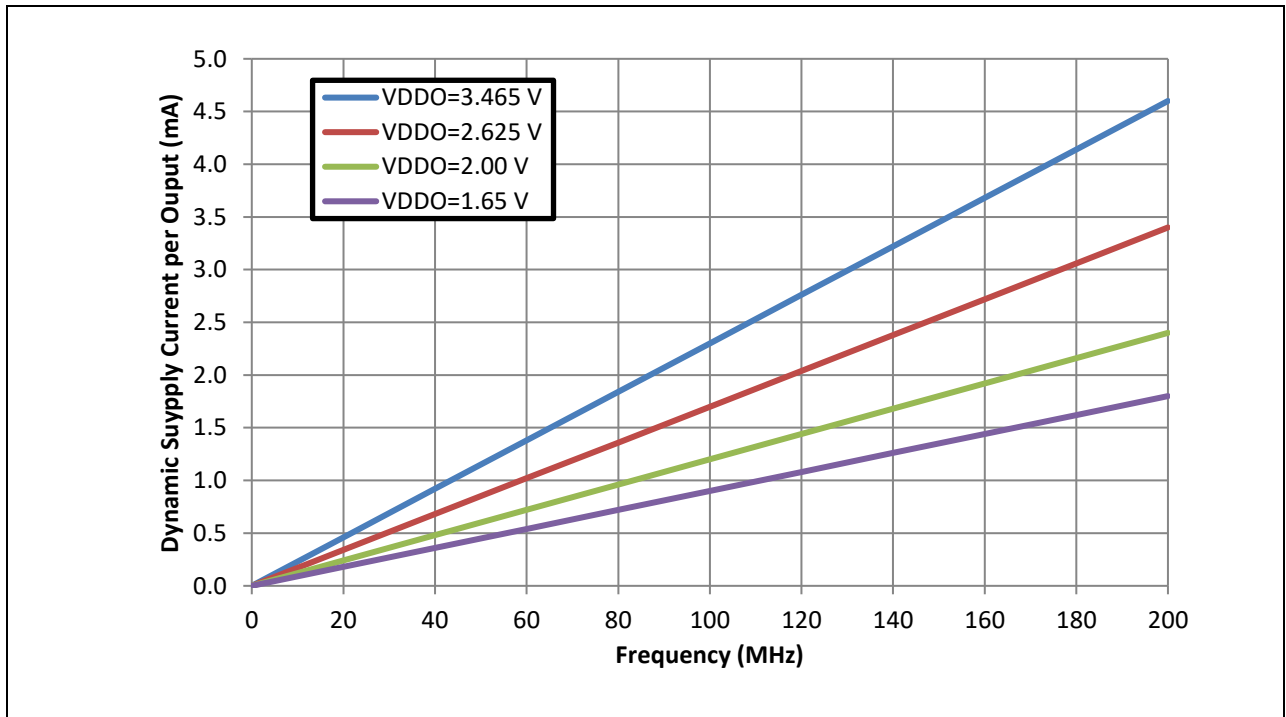

Figure 16. Dynamic supply current per output for different output supply voltages

Power Supply Filtering

Each power pin (VDD and VDDO) should be decoupled with 0.1µF capacitor with minimum equivalent series resistance (ESR) and minimum series inductance (ESL). For example, 0402 X5R Ceramic Capacitors with 6.3V minimum rating could be used. These capacitors should be placed as close as possible to the power pins. To reduce the power noise from adjacent digital components on the board each power supply could be further insulated with low resistance ferrite bead with two capacitors. The ferrite bead will also insulate adjacent component from the noise generated from the device. Following figure shows recommended decoupling for each power pin.

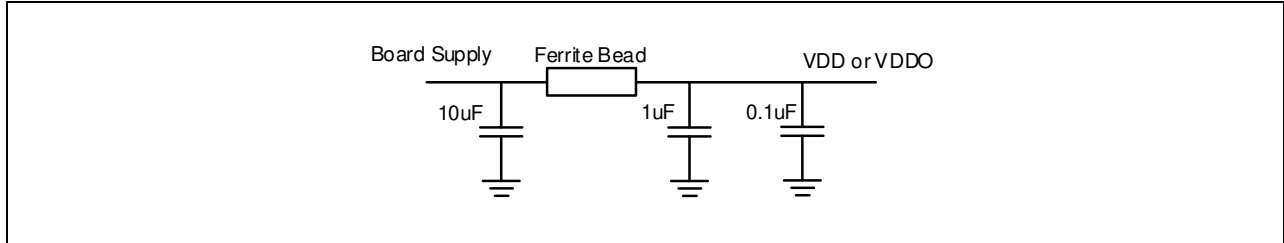

Figure 17. Power Supply Filtering

Device Control

ZL40241 is controlled via Output Enable (OE) and Input Select (SEL0/1) input pins

AC and DC Electrical Characteristics

Absolute Maximum Ratings

Table 2 · Absolute Maximum Ratings*

	Parameter	Sym.	Min.	Typ.	Max.	Units	Notes
1	Supply voltage (3.3V)	V _{DD} /V _{DDO}	-0.5		4.6	V	
2	Supply voltage (2.5V)	V _{DD} /V _{DDO}	-0.5		4.6	V	
3	Supply voltage (1.8V)	V _{DDO}	-0.5		2.5	V	
4	Supply voltage (1.5V)	V _{DDO}	-0.5		2.0	V	
5	Storage temperature	T _{ST}	-55		125	°C	

- * Exceeding these values may cause permanent damage
- * Functional operation under these conditions is not implied
- * Voltages are with respect to ground (GND) unless otherwise stated

Recommended Operating Conditions

Table 3 · Recommended Operating Conditions*

	Characteristics	Sym.	Min.	Typ.	Max.	Units	Notes
1	Supply voltage 3.3V	V _{DD} /V _{DDO}	3.135	3.30	3.465	V	
2	Supply voltage 2.5V	V _{DD} /V _{DDO}	2.375	2.50	2.625	V	
3	Supply voltage 1.8V	V _{DDO}	1.6	1.8V	2	V	
4	Supply voltage 1.5V	V _{DDO}	1.35	1.5	1.65		
5	Operating temperature	T _A	-40	25	85	°C	
6	Input voltage	V _{DD-IN}	- 0.3		V _{DD} + 0.3	V	

- * Voltages are with respect to ground (GND) unless otherwise stated
- * The device supports two power supply modes (3.3V and 2.5V)

Table 4 · Current consumption

	Characteristics	Sym.	Min.	Typ.	Max.	Units	Notes
1	Static device current	I _{s_3.3V}		15	18	mA	VDD= 3.465V
		I _{s_2.5V}		12	15	mA	VDD = 2.625V
2	Device current with 25MHz XTAL input	I _{DD_XTAL_3.3V}		24	27	mA	VDD= 3.465V
		I _{DD_XTAL_2.5V}		18	20	mA	VDD= 2.625V
3	Dynamic current per output (f = 100MHz) ⁽¹⁾⁽²⁾ Needs to be scaled for different frequencies by f/100MHz, Driving Strength = 1 (registers 0x09, 0x0A)	I _{DD_3.3V}		4.2	4.7	mA	VDDO= 3.465V
		I _{DD_2.5V}		3.0	3.5	mA	VDDO= 2.625V
		I _{DD_1.8V}		2.1	2.4	mA	VDDO= 2V
		I _{DD_1.5V}		1.6	1.8	mA	VDDO= 1.65V
4	Dynamic current per output (f = 100MHz) ⁽¹⁾⁽²⁾ Needs to be scaled for different frequencies by f/100MHz, Driving Strength = 0 (registers 0x09, 0x0A)	I _{DD_3.3V}		2.3	3.0	mA	VDDO= 3.465V
		I _{DD_2.5V}		1.7	1.8	mA	VDDO= 2.625V
		I _{DD_1.8V}		1.2	1.3	mA	VDDO= 2V
		I _{DD_1.5V}		0.9	1.0	mA	VDDO= 1.65V
5	Common output current ⁽³⁾	I _{DDC_3.3V}		3.8	8.0	mA	VDDO= 3.465V
		I _{DDC_2.5V}		1.9	3.3	mA	VDDO= 2.625V
		I _{DDC_1.8V}		1.2	1.7	mA	VDDO= 2V
		I _{DDC_1.5V}		1	1.4	mA	VDDO= 1.65V

- (1) Needs to be scaled for different frequencies by f/100MHz
- (2) To calculate total power consumption use following formula: P = (I_s + I_{DD_XTAL}) * VDD + (I_{DDC} + I_{DD} * n * f/100MHz + VDDO * C_{LOAD} * f * n) * VDDO, where I_{DD_XTAL}: should be set to zero if XTAL is not used or I_s should be set to zero if XTAL is used.
n: number of active outputs
f: frequency of the clock
C_{LOAD}: is capacitive load driven by an output.
- (3) This current is consumed by device whenever one or more outputs are enabled. It is independent of the number of active outputs

Table 5 · Input Characteristics*

	Characteristics	Sym.	Min.	Typ.	Max.	Units	Notes
1	CMOS high-level input voltage for SEL0/1 and OE	V_{CH}	1.20			V	
2	CMOS low-level input voltage for SEL0/1 and OE	V_{CIL}			0.45	V	
3	CMOS input leakage current for SEL0/1 and OE ⁽¹⁾	I_{IL}	-40		10	μ A	$V_I = V_{DD}$ or 0 V
4	Differential input common mode voltage for IN0_p/n and IN1_p/n	V_{CM}	0.5		$V_{DD} - 0.85$	V	
5	Differential input voltage difference for IN0_p/n and IN1_p/n	V_{ID}	0.15		1.3	V	
6	Differential input leakage current for IN0_p/n and IN1_p/n ⁽²⁾	I_{IL}	-200		100	μ A	$V_I = V_{DD}$ or 0 V
7	Single ended input high voltage for IN_0_p and IN_1_p	V_{SIH}	2		$V_{DD} + 0.3V$	V	$V_{DD} = 3.3V \pm 5\%$
		V_{SIH}	1.6		$V_{DD} + 0.3V$	V	$V_{DD} = 2.5V \pm 5\%$
8	Single ended input high voltage for IN_0_p and IN_1_p	V_{SIL}	-0.3		1.3	V	$V_{DD} = 3.3V \pm 5\%$
		V_{SIL}	-0.3		0.9	V	$V_{DD} = 2.5V \pm 5\%$
9	Input frequency	f_{IN}	0		200	MHz	
10	Input duty cycle	dc	35%		65%		@200MHz; for lower frequencies duty cycle can be scaled proportionally
11	Input slew rate	slew		2		V/ns	
12	Input pull-up/ pull-down resistance (INx_n)	R_{PU}/R_{PD}		60k Ω			
13	Input pull-down resistance (INx_p)	R_{PD}		30k Ω			

* Values are over Recommended Operating Conditions

* Values are over all two power supply modes ($V_{DD} = 3.3V$ and $V_{DD} = 2.5V$)

(1) CMOS input leakage is due to 300k Ω pull-up/pull-down resistors

(2) Differential Input leakage is due to 60k Ω pull-up/pull-down resistors INx_n and due to 30k Ω pull-down resistor for INx_p

Table 6 · Crystal Oscillator Characteristics*

	Characteristics	Sym.	Min.	Typ.	Max.	Units	Notes
1	Mode of oscillation	mode	Fundamental				
2	Frequency	f	8		60	MHz	
3	On chip shunt resistor	R		0.5		M Ω	
4	On chip capacitance	C		12		pF	
5	Frequency in overdrive mode ⁽¹⁾	f_{OV}	0.1		200	MHz	Functional but may not meet AC parameters Minimum depends on AC coupling Capacitor (0.1 μ F assumed)
6	Frequency in bypass mode ⁽²⁾	f_{BP}			200	MHz	Functional but may not meet AC parameters

* Values are over Recommended Operating Conditions

* Values are over all two power supply modes ($V_{DD} = 3.3V$ and $V_{DD} = 2.5V$)

(1) Maximum input level is 2V

(2) Maximum output level is VDD

Table 7 · LVCMOS Output Characteristics*

	Characteristics	Sym.	Min.	Typ.	Max.	Units	Notes
1	Output high voltage	V _{OH}	0.8*VDDO			V	VDDO = 3.3V±5%
		V _{OH}	0.8*VDDO			V	VDDO = 2.5V±5%
		V _{OH}	0.7*VDDO			V	VDDO = 1.8V±10%
		V _{OH}	0.7*VDDO			V	VDDO = 1.5V±10%
2	Output low voltage	V _{OL}			0.2*VDDO	V	VDDO = 3.3V±5%
		V _{OL}			0.2*VDDO	V	VDDO = 2.5V±5%
		V _{OL}			0.3*VDDO	V	VDDO = 1.8V±10%
		V _{OL}			0.3*VDDO	V	VDDO = 1.5V±10%
3	Output impedance	R _O		17		Ω	VDDO = 3.3V
		R _O		21		Ω	VDDO = 2.5V
		R _O		30		Ω	VDDO = 1.8V
		R _O		42		Ω	VDDO = 1.5V
4	Output slew rate-- rise or fall (20% to 80%)	t _r , t _f	3.19	5.14	6.33	V/ns	VDDO = 3.3V±5%
		t _r , t _f	1.72	3.74	4.61	V/ns	VDDO = 2.5V±5%
		t _r , t _f	1.64	2.52	3.32	V/ns	VDDO = 1.8V±10%
		t _r , t _f	1.20	1.96	2.54	V/ns	VDDO = 1.5V±10%
5	Output frequency	F _O	0		200	MHz	
6	Output Duty Cycle		50.26%		53.18%		Input. duty-cycle 50%
7	Output enable or disable time				2	Cycle	
8	Output to output skew	t _{oosk}			27	ps	
9	Device to device output skew	t _{oosk}			1.6	ns	
10	Input to output delay	t _{iOD}	1.15	2.09	2.54	ns	VDD = 3.3V
		t _{iOD}	1.57	2.27	2.77	ns	VDD = 2.5V
11	Input multiplexer isolation	i _{iso}	75			dB	tested with 125MHz clocks

* Values are over Recommended Operating Conditions

* Values are over all two power supply modes (V_{DD} = 3.3V and V_{DD} = 2.5V)

* Load 50 Ohm to VDDO/2

Table 8 · LVCMOS Output Additive Jitter and Phase Noise*

	Characteristics	Min.	Typ.	Max.	Units	Notes
1	System level additive jitter ⁽¹⁾		17		fs-RMS	VDD = 3.3V, VDDO = 3.3V f _{in} = 125MHz, single ended input
			31		fs-RMS	VDD = 2.5V, VDDO = 1.5V to 2.5V f _{in} = 125MHz, single ended input
			22		fs-RMS	VDD = 3.3V, VDDO = 3.3V f _{in} = 125MHz, differential input
			37		fs-RMS	VDD = 2.5V, VDDO = 1.5V to 2.5V f _{in} = 125MHz, differential input
2	Additive jitter ^{(2) (3)}		45.18	93.11	fs-RMS	VDD = 3.3V, VDDO = 3.3V f _{in} = 125MHz, single ended input
			80.46	126.92	fs-RMS	VDD = 2.5V, VDDO = 1.5V to 2.5V f _{in} = 125MHz, single ended input
			39.95	68.98	fs-RMS	VDD = 3.3V, VDDO = 3.3V f _{in} = 125MHz, differential input
			67.18	117.26	fs-RMS	VDD = 2.5V, VDDO = 1.5V to 2.5V f _{in} = 125MHz, differential input
3	Phase Noise floor (VDD = 3.3V, VDDO = 3.3V)		-145.08	-138.67	dBc/Hz	@10kHz, f _{in} = 125MHz, single ended input
			-152.46	-145.82	dBc/Hz	@100kHz, f _{in} = 125MHz, single ended input
			-160.67	-155.66	dBc/Hz	@1MHz, f _{in} = 125MHz, single ended input
			-162.66	-160.55	dBc/Hz	@10MHz, f _{in} = 125MHz, single ended input
			-162.71	-160.19	dBc/Hz	@20MHz, f _{in} = 125MHz, single ended input
			-145.34	-137.83	dBc/Hz	@10kHz, f _{in} = 125MHz, differential input
			-152.60	-146.93	dBc/Hz	@100kHz, f _{in} = 125MHz, differential input
			-161.06	-156.99	dBc/Hz	@1MHz, f _{in} = 125MHz, differential input
			-163.22	-160.84	dBc/Hz	@10MHz, f _{in} = 125MHz, differential input
			-163.38	-161.42	dBc/Hz	@20MHz, f _{in} = 125MHz, differential input
4	Phase Noise floor (VDD = 2.5V, VDDO = 2.5V)		-139.93	-134.59	dBc/Hz	@10kHz, f _{in} = 125MHz, single ended input
			-147.22	-144.21	dBc/Hz	@100kHz, f _{in} = 125MHz, single ended input
			-157.11	-154.78	dBc/Hz	@1MHz, f _{in} = 125MHz, single ended input
			-160.58	-158.21	dBc/Hz	@10MHz, f _{in} = 125MHz, single ended input
			-160.78	-158.19	dBc/Hz	@20MHz, f _{in} = 125MHz, single ended input
			-141.69	-134.26	dBc/Hz	@10kHz, f _{in} = 125MHz, differential input
			-149.19	-144.73	dBc/Hz	@100kHz, f _{in} = 125MHz, differential input
			-158.66	-156.22	dBc/Hz	@1MHz, f _{in} = 125MHz, differential input
			-161.60	-159.32	dBc/Hz	@10MHz, f _{in} = 125MHz, differential input
			-161.85	-159.36	dBc/Hz	@20MHz, f _{in} = 125MHz, differential input

* Values are over Recommended Operating Conditions

* Values are over all two power supply modes (V_{DD} = 3.3V and V_{DD} = 2.5V)

(1) System level additive jitter is calculated as $J_{RMS_SYS_AJ} = J_{RMS_OUT} - J_{RMS_IN}$

(2) Additive jitter is calculated as $J_{RMS_AJ} = \sqrt{J_{RMS_OUT}^2 - J_{RMS_IN}^2}$ where jitter is integrated in 12 kHz to 20 MHz band

Tester measures jitter at 156.25MHz. Since this freq won't appear in the data sheet, it should be removed from the PPGT. Data sheet jitter is guaranteed by lab char. The ATE jitter measurement will be used to screen outliers only, with limits based on ATE distribution

Table 9 · LVCMOS Output Jitter Phase Noise with 25MHz XTAL*

	Characteristics	Min.	Typ.	Max.	Units	Notes
1	Jitter RMS in 12kHz to 20MHz band		72.63		fs	VDD = 3.3V, VDDO = 3.3V
			87.59		fs	VDD = 2.5V; VDDO = 2.5V
2	Phase Noise floor		-75.96		dBc/Hz	@10Hz, VDD = 3.3V, VDDO = 3.3V
			-107.50		dBc/Hz	@100Hz, VDD = 3.3V, VDDO = 3.3V
			-132.34		dBc/Hz	@1kHz, VDD = 3.3V, VDDO = 3.3V
			-157.36		dBc/Hz	@10kHz, VDD = 3.3V, VDDO = 3.3V
			-165.82		dBc/Hz	@100kHz, VDD = 3.3V, VDDO = 3.3V
			-168.85		dBc/Hz	@1MHz, VDD = 3.3V, VDDO = 3.3V
			-168.88		dBc/Hz	@5MHz, VDD = 3.3V, VDDO = 3.3V
			-70.52		dBc/Hz	@10Hz, VDD = 2.5V; VDDO = 2.5V
			-102.60		dBc/Hz	@100Hz, VDD = 2.5V; VDDO = 2.5V
			-129.14		dBc/Hz	@1kHz, VDD = 2.5V; VDDO = 2.5V
			-153.93		dBc/Hz	@10kHz, VDD = 2.5V; VDDO = 2.5V
			-164.00		dBc/Hz	@100kHz, VDD = 2.5V; VDDO = 2.5V
			-167.34		dBc/Hz	@1MHz, VDD = 2.5V; VDDO = 2.5V
			-167.41		dBc/Hz	@5MHz, VDD = 2.5V; VDDO = 2.5V

* Values are over Recommended Operating Conditions

* Values are over all two power supply modes (V_{DD} = 3.3V and V_{DD} = 2.5V)

* Xtal frequency is 25 MHz

Table 10 · 5x5mm QFN Package Thermal Properties

Parameter	Symbol	Conditions	Value	Units
Maximum Ambient Temperature	T _A		85	°C
Maximum Junction Temperature	T _{JMAX}		125	°C
Junction to Ambient Thermal Resistance ⁽¹⁾ (Note 1)	θ _{JA}	still air	26.8	°C/W
		1m/s airflow	21.8	
		2.5m/s airflow	19.9	
Junction to Board Thermal Resistance	θ _{JB}		10.8	°C/W
Junction to Case Thermal Resistance	θ _{JC}		19.5	°C/W
Junction to Pad Thermal Resistance ⁽²⁾	θ _{JP}	Still air	6.5	°C/W
Junction to Top-Center Thermal Characterization Parameter	ψ _{JT}	Still air	0.6	°C/W

(1) Theta-JA (θ_{JA}) is the thermal resistance from junction to ambient when the package is mounted on an 4-layer JEDEC standard test board and dissipating maximum power

(2) Theta-JP (θ_{JP}) is the thermal resistance from junction to the center exposed pad on the bottom of the package)

Package Outline

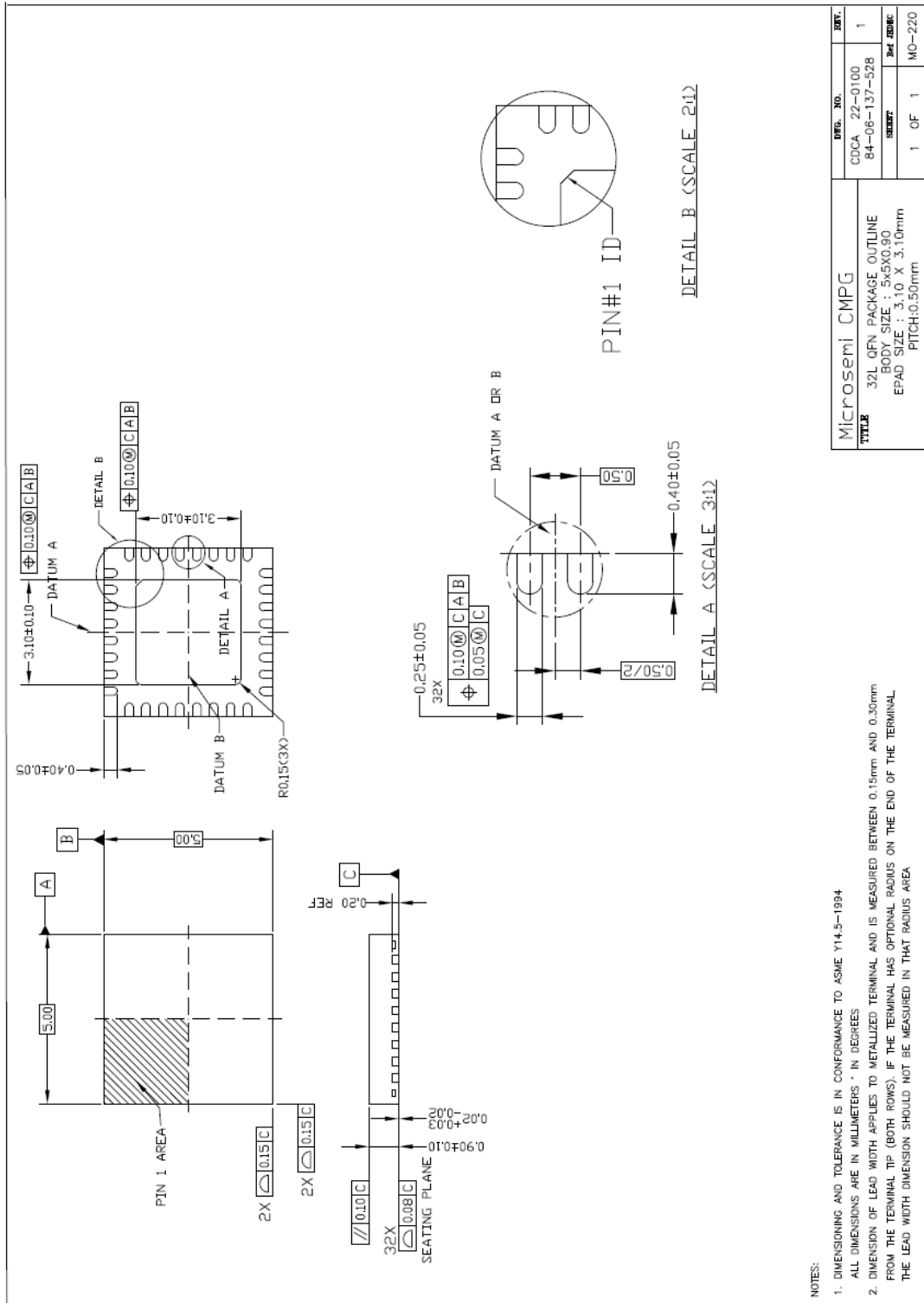

Revision History

February 2017: Initial Release

July 2018: Release changes:

- Added note in pinout to tie XIN pin when crystal circuit is not used
- Fixed several typographical errors.

October 2018: Release changes:

- Removed Figures 18, and 19 due to inaccuracy



Microsemi Corporate Headquarters

One Enterprise, Aliso Viejo,
CA 92656 USA

Within the USA: +1 (800) 713-4113

Outside the USA: +1 (949) 380-6100

Sales: +1 (949) 380-6136

Fax: +1 (949) 215-4996

E-mail: sales.support@microsemi.com

© 2018 Microsemi Corporation. All rights reserved. Microsemi and the Microsemi logo are trademarks of Microsemi Corporation. All other trademarks and service marks are the property of their respective owners.

Microsemi Corporation, a wholly owned subsidiary Microchip Technology Inc. (Nasdaq: MCHP), offers a comprehensive portfolio of semiconductor and system solutions for communications, defense & security, aerospace and industrial markets. Products include high-performance and radiation-hardened analog mixed-signal integrated circuits, FPGAs, SoCs and ASICs; power management products; timing and synchronization devices and precise time solutions, setting the world's standard for time; voice processing devices; RF solutions; discrete components; enterprise storage and communication solutions, security technologies and scalable anti-tamper products; Ethernet solutions; Power-over-Ethernet ICs and midspans; as well as custom design capabilities and services. Microsemi is headquartered in Aliso Viejo, California. Learn more at www.microsemi.com.

Microsemi makes no warranty, representation, or guarantee regarding the information contained herein or the suitability of its products and services for any particular purpose, nor does Microsemi assume any liability whatsoever arising out of the application or use of any product or circuit. The products sold hereunder and any other products sold by Microsemi have been subject to limited testing and should not be used in conjunction with mission-critical equipment or applications. Any performance specifications are believed to be reliable but are not verified, and Buyer must conduct and complete all performance and other testing of the products, alone and together with, or installed in, any end-products. Buyer shall not rely on any data and performance specifications or parameters provided by Microsemi. It is the Buyer's responsibility to independently determine suitability of any products and to test and verify the same. The information provided by Microsemi hereunder is provided "as is, where is" and with all faults, and the entire risk associated with such information is entirely with the Buyer. Microsemi does not grant, explicitly or implicitly, to any party any patent rights, licenses, or any other IP rights, whether with regard to such information itself or anything described by such information. Information provided in this document is proprietary to Microsemi, and Microsemi reserves the right to make any changes to the information in this document or to any products and services at any time without notice.