



Is Now Part of



ON Semiconductor®

To learn more about ON Semiconductor, please visit our website at
www.onsemi.com

Please note: As part of the Fairchild Semiconductor integration, some of the Fairchild orderable part numbers will need to change in order to meet ON Semiconductor's system requirements. Since the ON Semiconductor product management systems do not have the ability to manage part nomenclature that utilizes an underscore (_), the underscore (_) in the Fairchild part numbers will be changed to a dash (-). This document may contain device numbers with an underscore (_). Please check the ON Semiconductor website to verify the updated device numbers. The most current and up-to-date ordering information can be found at www.onsemi.com. Please email any questions regarding the system integration to Fairchild_questions@onsemi.com.

ON Semiconductor and the ON Semiconductor logo are trademarks of Semiconductor Components Industries, LLC dba ON Semiconductor or its subsidiaries in the United States and/or other countries. ON Semiconductor owns the rights to a number of patents, trademarks, copyrights, trade secrets, and other intellectual property. A listing of ON Semiconductor's product/patent coverage may be accessed at www.onsemi.com/site/pdf/Patent-Marking.pdf. ON Semiconductor reserves the right to make changes without further notice to any products herein. ON Semiconductor makes no warranty, representation or guarantee regarding the suitability of its products for any particular purpose, nor does ON Semiconductor assume any liability arising out of the application or use of any product or circuit, and specifically disclaims any and all liability, including without limitation special, consequential or incidental damages. Buyer is responsible for its products and applications using ON Semiconductor products, including compliance with all laws, regulations and safety requirements or standards, regardless of any support or applications information provided by ON Semiconductor. "Typical" parameters which may be provided in ON Semiconductor data sheets and/or specifications can and do vary in different applications and actual performance may vary over time. All operating parameters, including "Typicals" must be validated for each customer application by customer's technical experts. ON Semiconductor does not convey any license under its patent rights nor the rights of others. ON Semiconductor products are not designed, intended, or authorized for use as a critical component in life support systems or any FDA Class 3 medical devices or medical devices with a same or similar classification in a foreign jurisdiction or any devices intended for implantation in the human body. Should Buyer purchase or use ON Semiconductor products for any such unintended or unauthorized application, Buyer shall indemnify and hold ON Semiconductor and its officers, employees, subsidiaries, affiliates, and distributors harmless against all claims, costs, damages, and expenses, and reasonable attorney fees arising out of, directly or indirectly, any claim of personal injury or death associated with such unintended or unauthorized use, even if such claim alleges that ON Semiconductor was negligent regarding the design or manufacture of the part. ON Semiconductor is an Equal Opportunity/Affirmative Action Employer. This literature is subject to all applicable copyright laws and is not for resale in any manner.

FMS6501

12 Input / 9 Output Video Switch Matrix with Input Clamp, Input Bias Circuitry, and Output Drivers

Features

- 12 x 9 Crosspoint Matrix
- Supports SD, PS, and HD 1080i/1080p Video
- Input Clamp / Bias Circuitry
- AC or DC-Coupled Inputs
- AC or DC-Coupled Outputs
- Dual-Load (75Ω) Output Drivers with High-Impedance Disable
- One-to-One or One-to-Many Input to Output Switching
- Programmable Gain: +6, +7, +8, or +9dB
- I²C™ Compatible Digital Interface, Standard Mode
- 3.3V or 5V Single-Supply Operation
- Lead-Free SSOP-28 Package

Applications

- Cable and Satellite Set-Top Boxes
- TV and HDTV Sets
- A/V Switchers
- Personal Video Recorders (PVR)
- Security / Surveillance
- Video Distribution
- Automotive (In-Cabin Entertainment)

Description

The FMS6501 switch matrix provides flexible options for today's video applications. The 12 inputs that can be routed to any of nine outputs. Each input can be routed to one or more outputs, but only one input may be routed to any one output. The input to output routing is controlled via an I²C™-compatible digital interface.

Each input supports an integrated clamp option to set the output sync tip level of video with sync to ~300mV. Alternatively, the input may be internally biased to center signals without sync (Chroma, Pb, Pr) at ~1.25V. These DC output levels are for the 6dB gain setting. Higher gain settings increase the DC output levels accordingly. The input clamp / bias mode is selected via I²C.

Unused outputs may be powered down to reduce power dissipation.

Ordering Information

Part Number	Pb-Free	Temperature Range	Package	Container	Quantity
FMS6501MSA28	Yes	-40°C to 85°C	SSOP-28	Rail	47
FMS6501MSA28X	Yes	-40°C to 85°C	SSOP-28	Reel	2000

Block Diagram

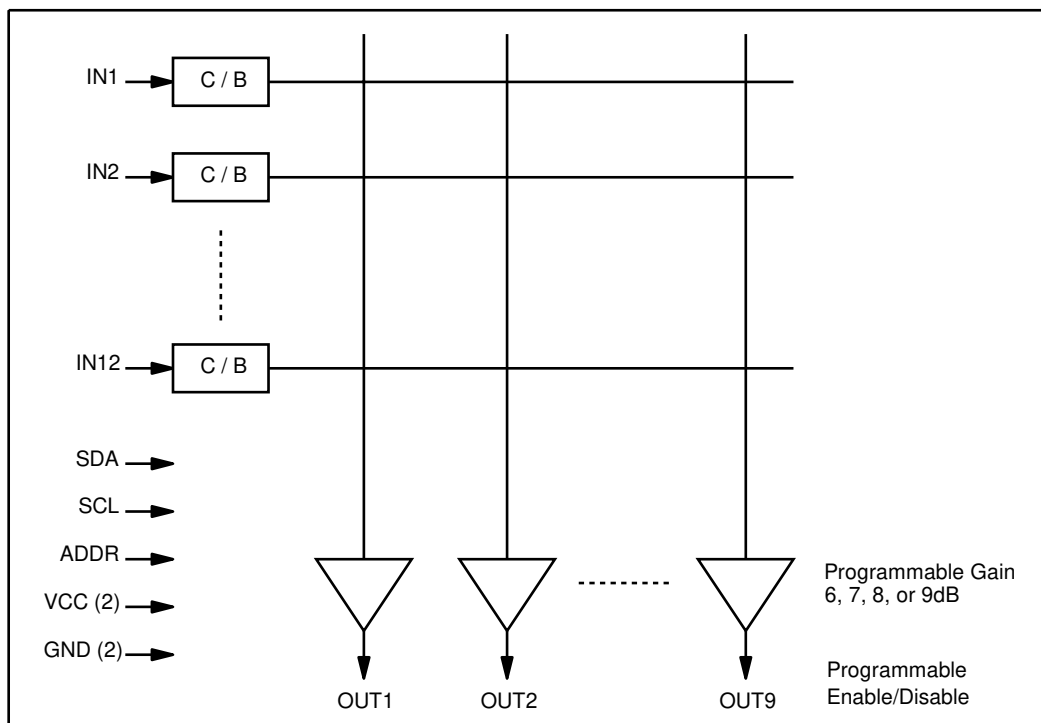

Figure 1. FMS6501 Block Diagram

Pin Configuration

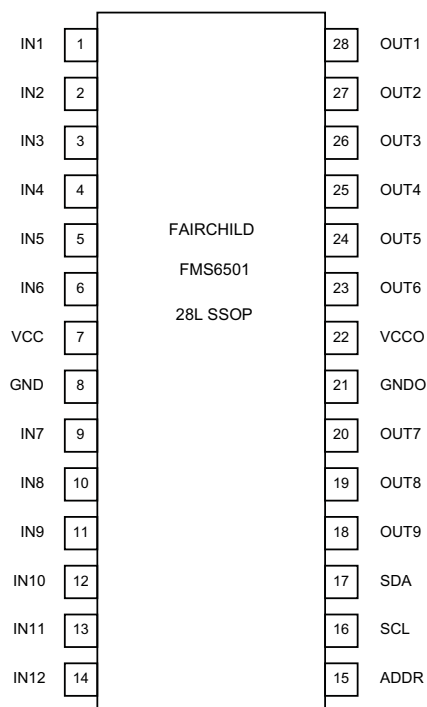

Figure 2. Pin Configuration

Pin Assignments

Pin#	Name	Type	Description
1	IN1	Input	Input, channel 1
2	IN2	Input	Input, channel 2
3	IN3	Input	Input, channel 3
4	IN4	Input	Input, channel 4
5	IN5	Input	Input, channel 5
6	IN6	Input	Input, channel 6
7	VCC	Input	Positive power supply
8	GND	Input	Must be tied to ground
9	IN7	Input	Input, channel 7
10	IN8	Input	Input, channel 8
11	IN9	Input	Input, channel 9
12	IN10	Input	Input, channel 10
13	IN11	Input	Input, channel 11
14	IN12	Input	Input, channel 12
15	ADDR	Input	Selects I ² C address. "0" = 0x06 (0000 0110), "1" = 0x86 (1000 0110)
16	SCL	Input	Serial clock for I ² C port
17	SDA	Input	Serial data for I ² C port
18	OUT9	Output	Output, channel 9
19	OUT8	Output	Output, channel 8
20	OUT7	Output	Output, channel 7
21	GNDO	Input	Must be tied to ground
22	VCCO	Input	Positive power supply for output drivers
23	OUT6	Output	Output, channel 6
24	OUT5	Output	Output, channel 5
25	OUT4	Output	Output, channel 4
26	OUT3	Output	Output, channel 3
27	OUT2	Output	Output, channel 2
28	OUT1	Output	Output, channel 1

Absolute Maximum Ratings

Stresses exceeding the absolute maximum ratings may damage the device. The device may not function or be operable above the recommended operating conditions and stressing the parts to these levels is not recommended. In addition, extended exposure to stresses above the recommended operating conditions may affect device reliability. The absolute maximum ratings are stress ratings only.

Parameter	Min.	Max.	Unit
DC Supply Voltage	-0.3	6.0	V
Analog and Digital I/O	-0.3	$V_{CC} + 0.3$	V
Output Current Any One Channel, Do Not Exceed		40	mA

Reliability Information

Symbol	Parameter	Min.	Typ.	Max.	Unit
T_J	Junction Temperature			150	°C
T_{STG}	Storage Temperature Range	-65		150	°C
T_L	Lead Temperature (Soldering, 10 seconds)			300	°C
Θ_{JA}	Thermal Resistance, JEDEC Standard Multilayer Test Board, Still Air		50		°C/W

Recommended Operating Conditions

The Recommended Operating Conditions table defines the conditions for actual device operation. Recommended operating conditions are specified to ensure optimal performance to the datasheet specifications. Fairchild does not recommend exceeding them or designing to absolute maximum ratings.

Symbol	Parameter	Min.	Typ.	Max.	Unit
T_A	Operating Temperature Range	-40		85	°C
V_{CC}	Supply Voltage Range	3.135	5.000	5.250	V

Electrostatic Discharge Protection

Symbol	Parameter	Value	Unit
HBM	Human Body Model	5	kV
CDM	Charged Device Model	2	kV

Digital Interface

The I²C-compatible interface is used to program output enables, input to output routing, input clamp / bias, and output gain. The I²C address of the FMS6501 is 0x06 (0000 0110) with the ability to offset it to 0x86 (1000 0110) by tying the ADDR pin high.

Both data and address data, of eight bits each, are written to the I²C address to access all the control functions.

There are separate internal addresses for each output. Each output's address includes bits to select an input channel, adjust the output gain, and enable or disable the output amplifier. More than one output can select the

same input channel for one-to-many routing. When the outputs are disabled, they are placed in a high-impedance state. This allows multiple FMS6501 devices to be paralleled to create a larger switch matrix. Typical output power-up time is less than 500ns.

The clamp / bias control bits are written to their own internal address, since they should always remain the same regardless of signal routing. They are set based on the input signal connected to the FMS6501.

All undefined addresses may be written without effect.

Output Control Register Contents and Defaults

Control Name	Width	Type	Default	Bit(s)	Description
Enable	1 bit	Write	0	7	Channel Enable: 1=Enable, 0=Power Down ⁽¹⁾
Gain	2 bits	Write	0	6:5	Channel Gain: 00=6dB, 01=7dB, 10=8dB, 11=9dB
Inx	5 bits	Write	0	4:0	Input selected to drive this output: 00000=OFF ⁽²⁾ , 00001=IN1, 00010=IN2... 01100=IN12

Notes:

1. Power down places the output in a high-impedance state so multiple FMS6501 devices may be paralleled. Power down also de-selects any input routed to the specified output.
2. When all inputs are OFF, the amplifier input is tied to approximately 150mV and the output goes to approximately 300mV with the 6dB gain setting.

Output Control Register MAP

Register Name	Register Address	Bit 7	Bit 6	Bit5	Bit4 ⁽¹⁾	Bit3	Bit2	Bit1	Bit0
OUT1	0x01	Enable	Gain1	Gain0	IN4	IN3	IN2	IN1	IN0
OUT2	0x02	Enable	Gain1	Gain0	IN4	IN3	IN2	IN1	IN0
OUT3	0x03	Enable	Gain1	Gain0	IN4	IN3	IN2	IN1	IN0
OUT4	0x04	Enable	Gain1	Gain0	IN4	IN3	IN2	IN1	IN0
OUT5	0x05	Enable	Gain1	Gain0	IN4	IN3	IN2	IN1	IN0
OUT6	0x06	Enable	Gain1	Gain0	IN4	IN3	IN2	IN1	IN0
OUT7	0x07	Enable	Gain1	Gain0	IN4	IN3	IN2	IN1	IN0
OUT8	0x08	Enable	Gain1	Gain0	IN4	IN3	IN2	IN1	IN0
OUT9	0x09	Enable	Gain1	Gain0	IN4	IN3	IN2	IN1	IN0

Notes:

1. IN4 is provided for forward compatibility and should always be written as '0' in the FMS6501.

Clamp Control Register Contents and Defaults

Control Name	Width	Type	Default	Bit(s)	Description
Clmp	1 bit	Write	0	7:0	Clamp / Bias selection: 1 = Clamp, 0 = Bias

Clamp Control Register Map

Register Name	Register Address	Bit 7	Bit 6	Bit5	Bit4	Bit3	Bit2	Bit1	Bit0
CLAMP1	0x1D	Clmp8	Clmp7	Clmp6	Clmp5	Clmp4	Clmp3	Clmp2	Clmp1
CLAMP2	0x1E	Resv'd	Resv'd	Resv'd	Resv'd	Clmp12	Clmp11	Clmp10	Clmp9

DC Electrical Characteristics

$T_A = 25^\circ\text{C}$, $V_{CC} = 5\text{V}$, $V_{IN} = 1V_{pp}$, input bias mode, one-to-one routing, 6dB gain, all inputs AC coupled with $0.1\mu\text{F}$, unused inputs AC-terminated through 75Ω to GND, all outputs AC coupled with $220\mu\text{F}$ into 150Ω loads, referenced to 400kHz, unless otherwise noted.

Symbol	Parameter	Conditions	Min.	Typ.	Max	Units
I_{CC}	Supply Current ¹	No load, all outputs enabled		80	100	mA
V_{OUT}	Video Output Range			2.8		V_{pp}
R_{OFF}	Off Channel Output Impedance	Output disabled		3.0		$k\Omega$
V_{clamp}	DC Output Level ¹	Clamp mode	0.2	0.3	0.4	V
V_{bias}	DC Output Level ¹	Bias mode	1.15	1.25	1.35	V
PSRR	Power Supply Rejection Ratio	All channels, DC		50		dB

Notes:

- 100% tested at 25°C .

AC Electrical Characteristics

$T_A = 25^\circ\text{C}$, $V_{CC} = 5\text{V}$, $V_{IN} = 1V_{pp}$, input bias mode, one-to-one routing, 6dB gain, all inputs AC coupled with $0.1\mu\text{F}$, unused inputs AC-terminated through 75Ω to GND, all outputs AC coupled with $220\mu\text{F}$ into 150Ω loads, referenced to 400kHz, unless otherwise noted.

Symbol	Parameter	Conditions	Min.	Typ.	Max	Units
AV_{SD}	Channel Gain ⁽¹⁾ Error	All Channels, All Gain Settings, DC	-0.2	0	+0.2	dB
AV_{STEP}	Gain Step ⁽¹⁾	All Channels, DC	0.9	1.0	1.1	dB
f_{+1dB}	1dB Peaking Bandwidth	$V_{OUT} = 1.4V_{pp}$		65		MHz
f_{-1dB}	-1dB Bandwidth	$V_{OUT} = 1.4V_{pp}$		90		MHz
f_C	-3dB Bandwidth	$V_{OUT} = 1.4V_{pp}$		115		MHz
dG	Differential Gain	3.58MHz		0.1		%
dP	Differential Phase	3.58MHz		0.2		deg
THD_{SD}	SD Output Distortion	$V_{OUT} = 1.4V_{pp}$, 5MHz		0.05		%
THD_{HD}	HD Output Distortion	$V_{OUT} = 1.4V_{pp}$, 22MHz		0.6		%
X_{TALK1}	Input Crosstalk	1MHz, $V_{OUT} = 2V_{pp}$ ⁽²⁾		-72		dB
X_{TALK2}	Input Crosstalk	15MHz, $V_{OUT} = 2V_{pp}$ ⁽²⁾		-50		dB
X_{TALK3}	Output Crosstalk	1MHz, $V_{OUT} = 2V_{pp}$ ⁽³⁾		-68		dB
X_{TALK4}	Output Crosstalk	15MHz, $V_{OUT} = 2V_{pp}$ ⁽³⁾		-61		dB
X_{TALK5}	Multi-Channel Crosstalk	Standard Video, $V_{OUT} = 2V_{pp}$ ⁽⁴⁾		-45		dB
SNR_{SD}	Signal-to-Noise Ratio ⁽⁵⁾	NTC-7 Weighting, 4.2MHz LP, 100kHz HP		73		dB
V_{NOISE}	Channel Noise	400kHz to 100MHz, Input Referred		20		nV/rtHz
AMP_{ON}	Amplifier Recovery Time	Post I ² C Programming		300		ns

Notes:

- 100% tested at 25°C .
- Adjacent input pair to adjacent output pair. Interfering input is through an open switch.
- Adjacent input pair to adjacent output pair. Interfering input is through a closed switch.
- Crosstalk of eight synchronous switching outputs onto single, asynchronous switching output.
- Signal-to-Noise Ratio (SNR) = $20 * \log(714\text{mV} / \text{rms noise})$.

I²C BUS Characteristics

T_A = 25°C and V_{CC} = 5V unless otherwise noted.

Symbol	Parameter	Conditions	Min.	Typ.	Max	Units
V _{il}	Digital Input Low ⁽¹⁾	SDA, SCL, ADDR	0		1.5	V
V _{ih}	Digital Input High ⁽¹⁾	SDA, SCL, ADDR	3.0		V _{CC}	V
f _{scl}	Clock Frequency	SCK		100		kHz
t _r	Input Rise Time	1.5V to 3V		1000		ns
t _f	Input Fall Time	1.5V to 3V		300		ns
t _{low}	Clock Low Period			4.7		μs
t _{high}	Clock High Period			4.0		μs
t _{SU,DAT}	Data Set-up Time			300		ns
t _{HD,DAT}	Data Hold Time			0		ns
t _{SU,STO}	Set-up Time from Clock High to Stop			4		μs
t _{BUF}	Start Set-up Time Following a Stop			4.7		μs
t _{HD,STA}	Start Hold Time			4		μs
t _{SU,STA}	Start Set-up Time Following Clock Low to High			4.7		μs

Notes:

1. 100% tested at 25°C.

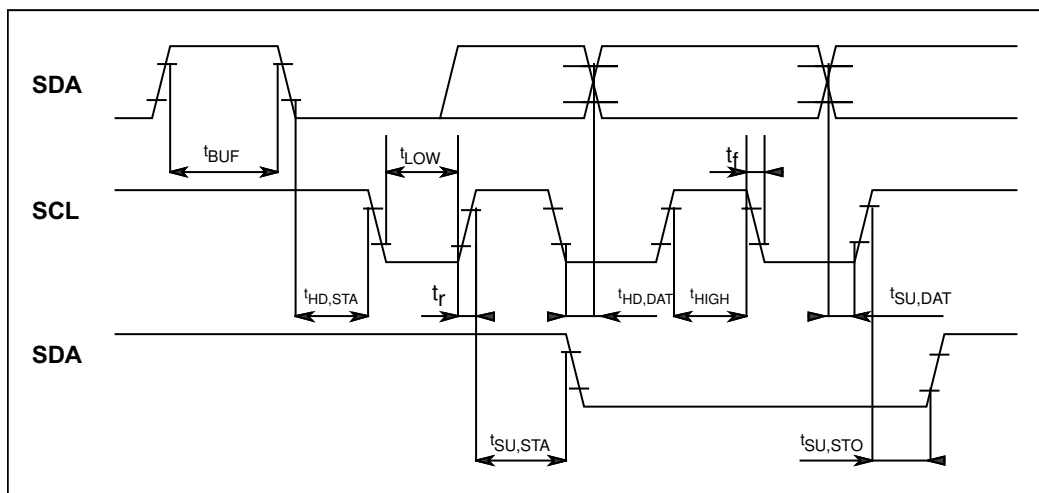

Figure 3. I²C Bus Timing

I²C Interface

Operation

The I²C-compatible interface conforms to the I²C specification for Standard Mode. Individual addresses may be written. There is no read capability. The interface consists of two lines. These is a serial data line (SDA) and a serial clock line (SCL), both of which must be connected to a positive supply through an external resistor. Data transfer may be initiated only when the bus is not busy.

Bit Transfer

One data bit is transferred during each clock pulse. The data on the SDA line must remain stable during the HIGH period of the clock pulse. Changes in the line during this time are interpreted as a control signal.

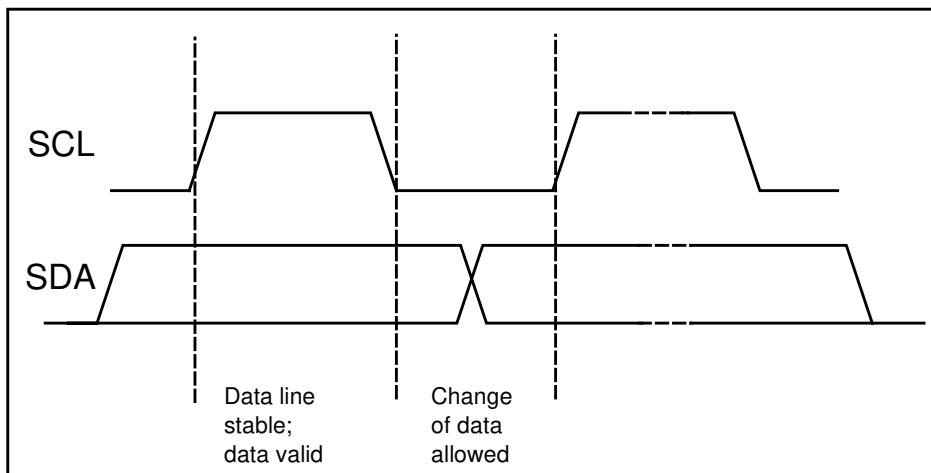

Figure 4. Bit Transfer

Start and Stop Conditions

The data and clock lines remain HIGH when the bus is not busy. A HIGH-to-LOW transition of the data line, while the clock is HIGH, is defined as START condition

(S). A LOW-to-HIGH transition of the data line, while the clock is HIGH, is defined as STOP condition (P).

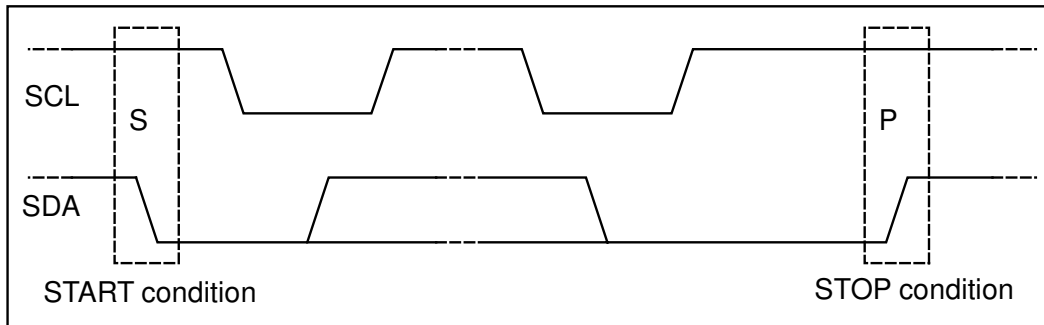

Figure 5. Definition of START and STOP conditions

Acknowledge

The data bytes transferred between the START and STOP conditions from transmitter to receiver is unlimited. Each byte of eight bits is followed by an acknowledge bit. The acknowledge bit is a high-level signal put on the bus by the transmitter, during which the master generates an extra acknowledge-related clock pulse. A slave receiver must generate an acknowledge after the reception of each byte. A master receiver must generate an acknowledge after the reception of each byte that has been clocked out of the slave transmitter.

The device that acknowledges must pull down the SDA line during the acknowledge clock pulse so the SDA line is stable LOW during the HIGH period of the acknowledge-related clock pulse (set-up and hold times must be taken into consideration). A master receiver must signal an end of data to the transmitter by not generating an acknowledge on the last byte clocked out of the slave. In this event, the transmitter must leave the data line HIGH to enable the master to generate a STOP condition.

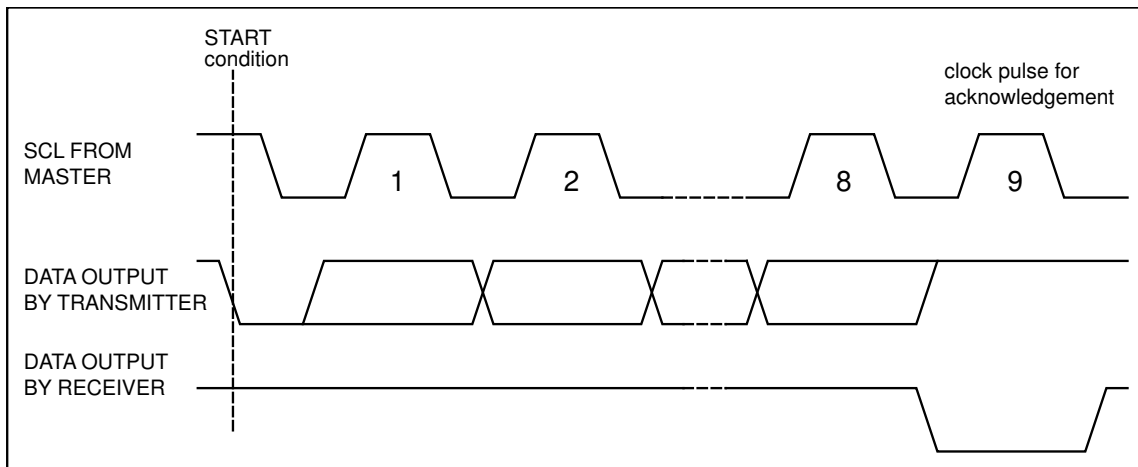

Figure 6. Acknowledgement on the I²C Bus

I²C Bus Protocol

Before any data is transmitted on the I²C bus, the device that should respond is addressed first. The addressing is always carried out with the first byte transmitted after the

start procedure. The I²C bus configuration for a data write to the FMS6501 is shown in Figure 5.

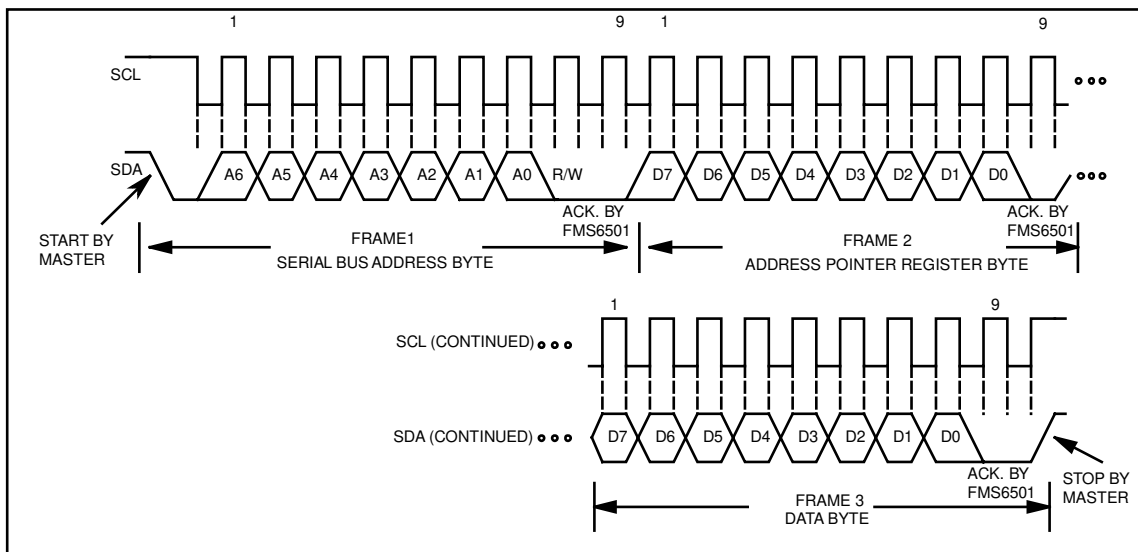

Figure 7. Write a Register Address to the Pointer Register, Then Write Data to the Selected Register

Applications Information

Input Clamp / Bias Circuitry

The FMS6501 accommodates AC- or DC-coupled inputs.

Internal clamping and bias circuitry are provided to support AC-coupled inputs. These are selectable through the CLMP bits via the I²C compatible interface.

For DC-coupled inputs, the device should be programmed to use the 'bias' input configuration. In this configuration, the input is internally biased to 625mV through a 100kΩ resistor. Distortion is optimized with the output levels set between 250mV above ground and 500mV below the power supply. These constraints, along with the desired channel gain, need to be considered when configuring the input signal levels for input DC coupling.

With AC-coupled inputs, the FMS6501 uses a simple clamp rather than a full DC-restore circuit. For video signals with and without sync (Y,CV,R,G,B), the lowest voltage at the output pins is clamped to approximately 300mV above ground when the 6dB gain setting is selected.

If symmetric AC-coupled input signals are used (chroma,Pb,Pr,Cb,Cr), the bias circuit described above can be used to center them within the input common range. The average DC value at the output is approximately 1.27V with a 6dB gain setting. This value changes depending upon the selected gain setting.

Gain Setting	Clamp Voltage	Bias Voltage
6dB	300mV	1.27V
7dB	330mV	1.43V
8dB	370mV	1.60V
9dB	420mV	1.80V

Figure 8 shows the clamp mode input circuit and the internally controlled voltage at the input pin for AC-coupled inputs.

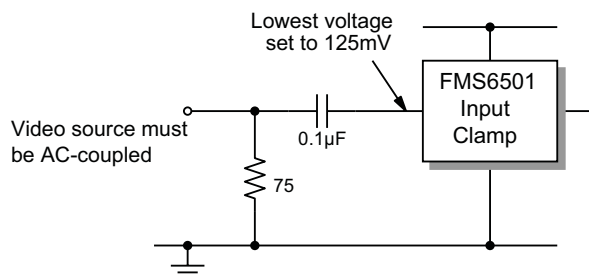

Figure 8. Clamp Mode Input Circuit

Figure 9 shows the bias mode input circuit and internally controlled voltage at the input pin for AC-coupled inputs.

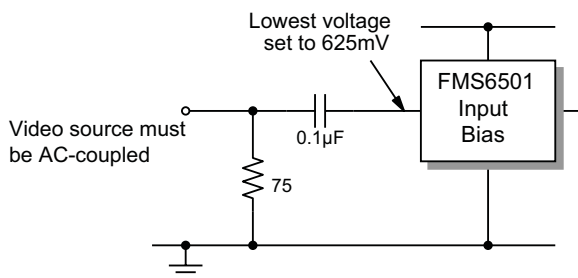

Figure 9. Bias Mode Input Circuit

Output Configuration

The FMS6501 outputs may be either AC or DC coupled. Resistive output loads can be as low as 75Ω, representing a dual, doubly terminated video load. High impedance, capacitive loads up to 20pF can also be driven without loss of signal integrity. For standard 75Ω video loads, a 75Ω matching resistor should be placed in series to allow for a doubly terminated load. DC-coupled outputs should be connected as shown in Figure 10.

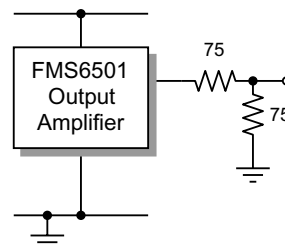

Figure 10. DC-Coupled Load Connection

If multiple low-impedance loads are DC coupled, increased power and thermal issues need to be addressed. In this case, the use of a multilayer board with a large ground plane to help dissipate heat is recommended. If a two-layer board is used under these conditions, an extended ground plane directly under the device is recommended. This plane should extend at least 0.5 inches beyond the device. PC board layout issues are covered in the Layout Considerations section.

AC-coupled loads should be configured as in Figure 11:

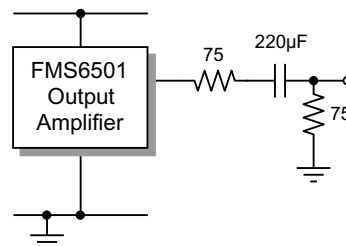

Figure 11. AC-Coupled Load Connection

Thermal issues are significantly reduced with AC-coupled outputs, alleviating special PC layout requirements.

Each of the outputs can be independently powered down and placed in a high-impedance state with the ENABLE bit. This function can be used to mute video signals, to parallel multiple FMS6501 outputs, or to save power. When the output amplifier is disabled, the high-impedance output presents a 3kΩ load to ground. The output amplifier typically enters and recovers from the power-down state in less than 300ns after being programmed.

When an output channel is not connected to an input, the input to that channel's amplifier is forced to approximately 150mV. The output amplifier is still active unless specifically disabled by the I²C interface. Voltage output levels depend on the programmed gain for that channel.

Crosstalk

Crosstalk is an important consideration when using the FMS6501. Input and output crosstalk are defined to represent the two major coupling modes in a typical application. Input crosstalk is crosstalk in the input pins and switches when the interfering signal drives an open switch. It is dominated by inductive coupling in the package lead frame between adjacent leads. It decreases rapidly as the interfering signal moves farther away from the pin adjacent to the input signal selected. Output crosstalk is coupling from one driven output to another active output. It decreases with increasing load impedance, as it is caused mainly by ground and power coupling between output amplifiers. If a signal is driving an open switch, its crosstalk is mainly input crosstalk. If it is driving a load through an active output, its crosstalk is mainly output crosstalk.

Input and output crosstalk measurements are performed with the test configuration shown in Figure 12.

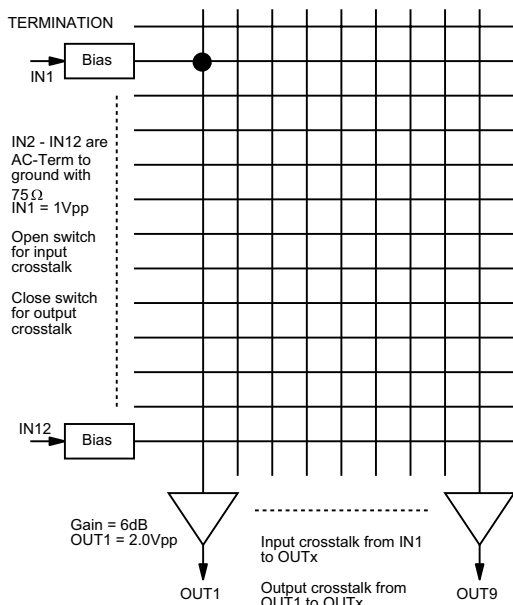

Figure 12. Test Configuration for Crosstalk

For input crosstalk, the switch is open. All inputs are in bias mode. Channel 1 input is driven with a 1V_{pp} signal, while all other inputs are AC terminated with 75Ω. All outputs are enabled and crosstalk is measured from IN1 to any output.

For output crosstalk, the switch is closed. Crosstalk from OUT1 to any output is measured.

Crosstalk from multiple sources into a given channel was measured with the setup shown in Figure 6. Input IN1 is driven with a 1V_{pp} pulse source and is connected to outputs Out1 to Out8. Input In9 is driven with a secondary, asynchronous, gray-field video signal, and is connected to Out9. All other inputs are AC terminated with 75Ω. Crosstalk effects on the gray field are measured and calculated with respect to a standard 1V_{pp} output measured at the load.

If not all inputs and outputs are needed, avoid using adjacent channels, where possible, to reduce crosstalk. Disable all unused channels to further reduce crosstalk and power dissipation.

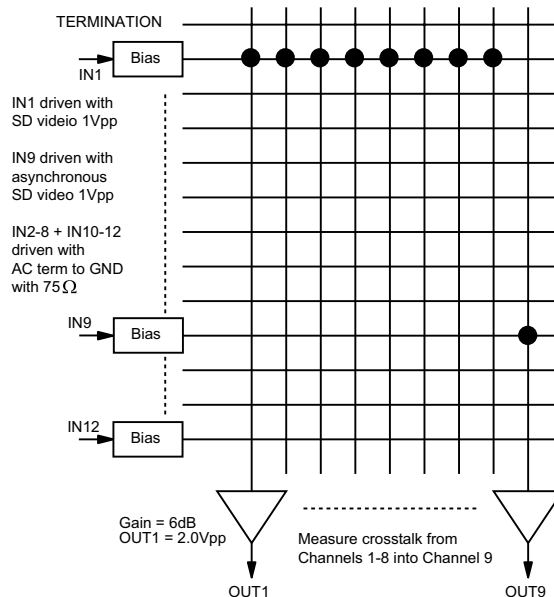

Figure 13. Test Configuration for Multi-Channel Crosstalk

Layout Considerations

General layout and supply bypassing play major roles in high-frequency performance and thermal characteristics. Fairchild offers a demonstration board, FMS6501DEMO, to use as a guide for layout and to aid in device testing and characterization. The FMS6501DEMO is a 4-layer board with a full power and ground plane. For optimum results, follow the steps below as a basis for high frequency layout.

- Include 10 μ F and 0.1 μ F bypass capacitors.
- Place the 10 μ F capacitor within 0.75 inches of the power pin.
- Place the 0.1 μ F capacitor within 0.1 inches of the power pin.
- Connect all external ground pins as tightly as possible, preferably with a large ground plane under the package.
- Layout channel connections to reduce mutual trace inductance.
- Minimize all trace lengths to reduce series inductances. If routing across a board, place device such that longer traces are at the inputs rather than the outputs.

If using multiple, low-impedance, DC-coupled outputs, special layout techniques may be employed to help dissipate heat.

If a multilayer board is used, a large ground plane directly under the device helps reduce package case temperature.

For dual-layer boards, an extended plane can be used.

Worst-case, additional die power due to DC loading can be estimated at $(V_{cc}^2/4R_{load})$ per output channel. This assumes a constant DC output voltage of $V_{cc}/2$. For 5V V_{cc} with a dual-DC video load, add $25/(4*75) = 83mW$, per channel.

FMS6501 Video Switch Matrix Applications

The increased demand for consumer multimedia systems has created a challenge for system designers to provide cost-effective solutions to capitalize on the growth potential in graphics display technologies. These applications requires cost-effective video switching and filtering solutions to deploy high-quality display technologies rapidly and effectively to the target audience. Areas of specific interest include HDTV, media centers, and automotive “infotainment” (includes navigation, in-cabin entertainment, and back-up camera). In all cases, the advantages an integrated video switch matrix provides are high quality video switching specific to the application, as well as video input clamps and on-chip, low-impedance output cable drivers with switchable gain.

Generally the largest application for a video switch is for the front end of an HDTV, where it takes multiple inputs and routes them to appropriate signal paths (main picture and picture in picture - PiP). These are normally routed into ADCs followed by decoders. There are many different technologies for HDTV; including LCD, Plasma, and CRT, with similar analog switching circuitry.

An example of a HDTV application is shown in Figure 14. This system combines a video switch matrix and two three-channel switchable anti-aliasing filters. There are two three-channel signal paths in the system; one for the main picture, the other for “Picture in Picture” (PiP).

VIPDEMO™ Control Software

The FMS6501 is configured via an I²C-compatible digital interface. To facilitate demonstration, Fairchild Semiconductor had developed the VIPDEMO™ GUI-based control software to write to the FMS6501 register map. This software is included in the FMS6501DEMO kit. Also included is a parallel port I²C adapter and an interface cable to connect to the demo board. Besides using the full FMS6501 interface, the VIPDEMO™ can also be used to control single-register read and writes for I²C.

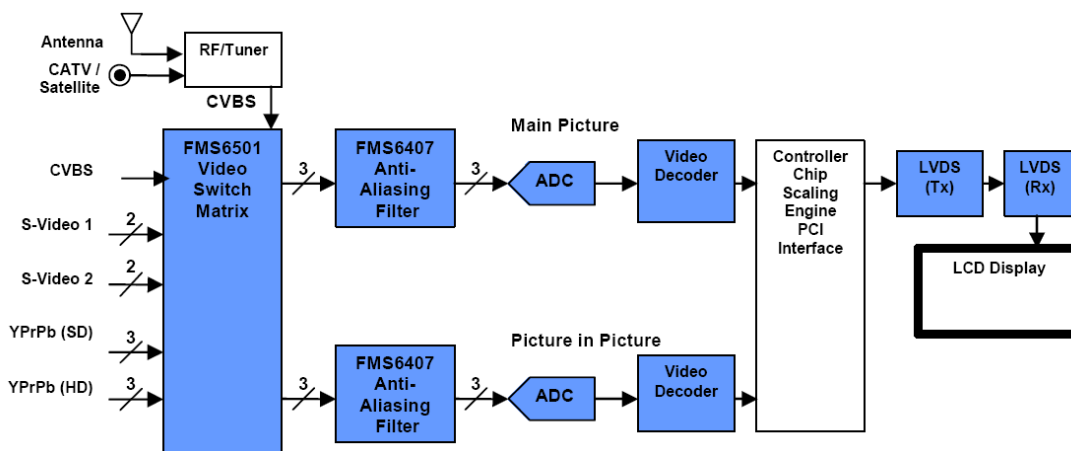

Figure 14. HDTV Application using the FMS6501 Video Switch Matrix

Physical Dimensions

Dimensions are in millimeters unless otherwise noted.

SSOP-28

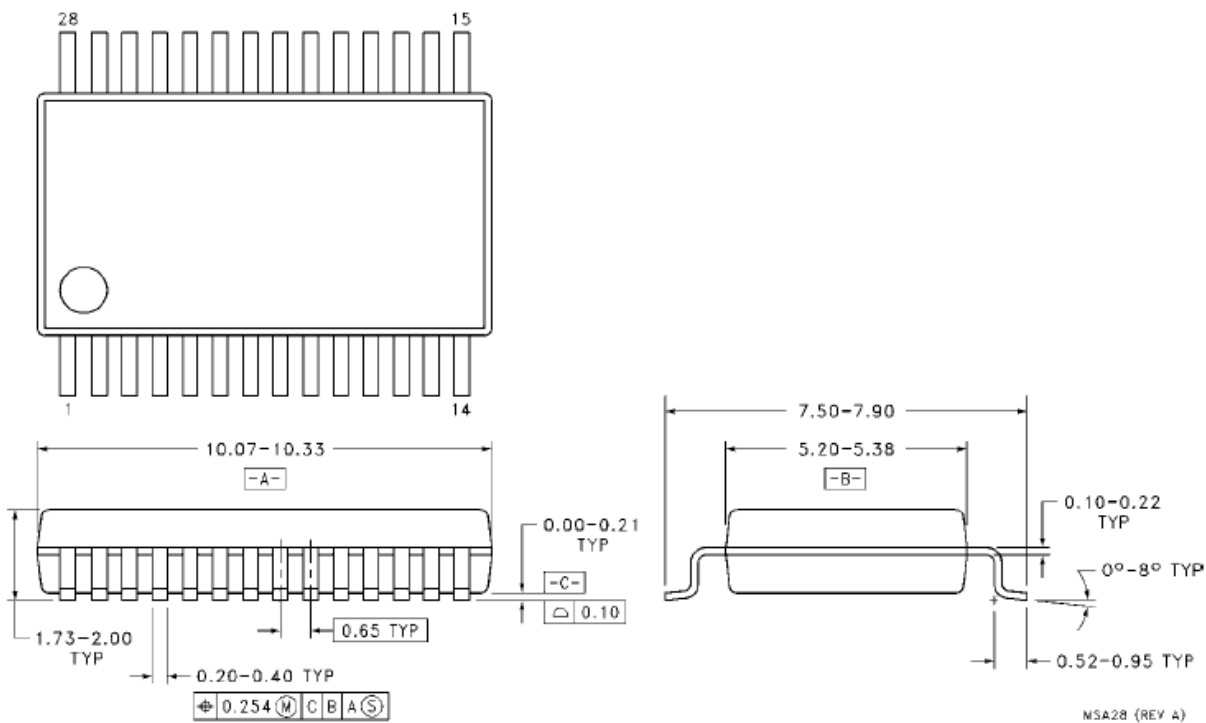



Figure 15. FMS6501 28-Lead Small Scale Outline Package (SSOP)



TRADEMARKS

The following are registered and unregistered trademarks Fairchild Semiconductor owns or is authorized to use and is not intended to be an exhaustive list of all such trademarks.

ACEx [®]	<i>i-Lo</i> [™]	Power-SPM [™]	TinyBoost [™]
Across the board. Around the world. [™]	ImpliedDisconnect [™]	PowerTrench [®]	TinyBuck [™]
ActiveArray [™]	IntelliMAX [™]	Programmable Active Droop [™]	TinyLogic [®]
Bottomless [™]	ISOPLANAR [™]	QFET [®]	TINYOPTO [™]
Build it Now [™]	MICROCOUPLER [™]	QST [™]	TinyPower [™]
CoolFET [™]	MicroPak [™]	QT Optoelectronics [™]	TinyWire [™]
CROSSVOLT [™]	MICROWIRE [™]	Quiet Series [™]	TruTranslation [™]
CTL [™]	Motion-SPM [™]	RapidConfigure [™]	μSerDes [™]
Current Transfer Logic [™]	MSX [™]	RapidConnect [™]	UHC [®]
DOME [™]	MSXPro [™]	ScalarPump [™]	UniFET [™]
E ² CMOS [™]	OCX [™]	SMART START [™]	VCX [™]
EcoSPARK [®]	OCXPro [™]	SPM [®]	Wire [™]
EnSigna [™]	OPTOLOGIC [®]	STEALTH [™]	
FACT Quiet Series [™]	OPTOPLANAR [®]	SuperFET [™]	
FACT [®]	PACMAN [™]	SuperSOT [™] .3	
FAST [®]	PDP-SPM [™]	SuperSOT [™] .6	
FASTr [™]	POP [™]	SuperSOT [™] .8	
FPST [™]	Power220 [®]	SyncFET [™]	
FRFET [®]	Power247 [®]	TCM [™]	
GlobalOptoisolator [™]	PowerEdge [™]	The Power Franchise [®]	
GTO [™]	PowerSaver [™]		
HiSeC [™]			

DISCLAIMER

FAIRCHILD SEMICONDUCTOR RESERVES THE RIGHT TO MAKE CHANGES WITHOUT FURTHER NOTICE TO ANY PRODUCTS HEREIN TO IMPROVE RELIABILITY, FUNCTION OR DESIGN. FAIRCHILD DOES NOT ASSUME ANY LIABILITY ARISING OUT OF THE APPLICATION OR USE OF ANY PRODUCT OR CIRCUIT DESCRIBED HEREIN; NEITHER DOES IT CONVEY ANY LICENSE UNDER ITS PATENT RIGHTS, NOR THE RIGHTS OF OTHERS. THESE SPECIFICATIONS DO NOT EXPAND THE TERMS OF FAIRCHILD'S WORLDWIDE TERMS AND CONDITIONS, SPECIFICALLY THE WARRANTY THEREIN, WHICH COVERS THESE PRODUCTS.

LIFE SUPPORT POLICY

FAIRCHILD'S PRODUCTS ARE NOT AUTHORIZED FOR USE AS CRITICAL COMPONENTS IN LIFE SUPPORT DEVICES OR SYSTEMS WITHOUT THE EXPRESS WRITTEN APPROVAL OF FAIRCHILD SEMICONDUCTOR CORPORATION.

As used herein:

1. Life support devices or systems are devices or systems which, (a) are intended for surgical implant into the body or (b) support or sustain life, and (c) whose failure to perform when properly used in accordance with instructions for use provided in the labeling, can be reasonably expected to result in a significant injury of the user.
2. A critical component in any component of a life support, device, or system whose failure to perform can be reasonably expected to cause the failure of the life support device or system, or to affect its safety or effectiveness.

PRODUCT STATUS DEFINITIONS

Definition of Terms

Datasheet Identification	Product Status	Definition
Advance Information	Formative or In Design	This datasheet contains the design specifications for product development. Specifications may change in any manner without notice.
Preliminary	First Production	This datasheet contains preliminary data; supplementary data will be published at a later date. Fairchild Semiconductor reserves the right to make changes at any time without notice to improve design.
No Identification Needed	Full Production	This datasheet contains final specifications. Fairchild Semiconductor reserves the right to make changes at any time without notice to improve design.
Obsolete	Not In Production	This datasheet contains specifications on a product that has been discontinued by Fairchild Semiconductor. The datasheet is printed for reference information only.

Rev. 126

ON Semiconductor and  are trademarks of Semiconductor Components Industries, LLC dba ON Semiconductor or its subsidiaries in the United States and/or other countries. ON Semiconductor owns the rights to a number of patents, trademarks, copyrights, trade secrets, and other intellectual property. A listing of ON Semiconductor's product/patent coverage may be accessed at www.onsemi.com/site/pdf/Patent-Marking.pdf. ON Semiconductor reserves the right to make changes without further notice to any products herein. ON Semiconductor makes no warranty, representation or guarantee regarding the suitability of its products for any particular purpose, nor does ON Semiconductor assume any liability arising out of the application or use of any product or circuit, and specifically disclaims any and all liability, including without limitation special, consequential or incidental damages. Buyer is responsible for its products and applications using ON Semiconductor products, including compliance with all laws, regulations and safety requirements or standards, regardless of any support or applications information provided by ON Semiconductor. "Typical" parameters which may be provided in ON Semiconductor data sheets and/or specifications can and do vary in different applications and actual performance may vary over time. All operating parameters, including "Typicals" must be validated for each customer application by customer's technical experts. ON Semiconductor does not convey any license under its patent rights nor the rights of others. ON Semiconductor products are not designed, intended, or authorized for use as a critical component in life support systems or any FDA Class 3 medical devices or medical devices with a same or similar classification in a foreign jurisdiction or any devices intended for implantation in the human body. Should Buyer purchase or use ON Semiconductor products for any such unintended or unauthorized application, Buyer shall indemnify and hold ON Semiconductor and its officers, employees, subsidiaries, affiliates, and distributors harmless against all claims, costs, damages, and expenses, and reasonable attorney fees arising out of, directly or indirectly, any claim of personal injury or death associated with such unintended or unauthorized use, even if such claim alleges that ON Semiconductor was negligent regarding the design or manufacture of the part. ON Semiconductor is an Equal Opportunity/Affirmative Action Employer. This literature is subject to all applicable copyright laws and is not for resale in any manner.

PUBLICATION ORDERING INFORMATION

LITERATURE FULFILLMENT:

Literature Distribution Center for ON Semiconductor
19521 E. 32nd Pkwy, Aurora, Colorado 80011 USA
Phone: 303-675-2175 or 800-344-3860 Toll Free USA/Canada
Fax: 303-675-2176 or 800-344-3867 Toll Free USA/Canada
Email: orderlit@onsemi.com

N. American Technical Support: 800-282-9855 Toll Free
USA/Canada
Europe, Middle East and Africa Technical Support:
Phone: 421 33 790 2910
Japan Customer Focus Center
Phone: 81-3-5817-1050

ON Semiconductor Website: www.onsemi.com
Order Literature: <http://www.onsemi.com/orderlit>
For additional information, please contact your local
Sales Representative