

39-Bit Battery Backup Multi-Turn Absolute Encoder

Data Sheet



Introduction

The AS37-H39B series encoder is a high-resolution optical absolute encoder produced by Broadcom[®], which offers 23-bit single-turn and 16-bit multi-turn counts, hence a combined 39-bit high resolution. The AS37-H39B series encoder is a house encoder consisting of a patterned disk, a light source, and photosensitive elements to translate the mechanical motion into electrical signal.

The AS37-H39B series encoder has a built-in communication protocol that is supported by a full-duplex or half-duplex line transmissions drive, offering good noise immunity for more robust transmission of data up to 10 Mb/s in harsh industrial application. Because the product is intended for industrial application, ESD protection circuitry has been designed in to achieve Class 3 ESD immunity per IEC -61000-4-2 standard. The AS37-H39B series is also compliant with IP40 per IEC 60529 standard.

The key advantage of the AS37-H39B series is multi-turn tracking employs battery backup technology. It is gearless multi-turn counting that eliminates the gear wear-out or acoustics noise issue that is encountered in conventional geared multi-turn encoder.

Operating Theory

Structures-wise, the encoder contains two main functional blocks: the single-turn optical engine block and the battery backup multi-turn counter block. The single-turn engine comprises the Broadcom developed high-performance optical detector ASIC, which is accompanied by high-precision amplifiers circuitry, coupled with a special multi-track code disk that rotates between the LED emitter and detector IC.

On the multi-turn side, the multi-turn counting is enabled utilizing battery backup counter technology. During battery mode (encoder operates in main power OFF state), the battery backup circuitry periodically powers up the LED emitter and enables the photo sensor to scan the code disk multi-turn tracks for detection of shaft rotation. In order to prolong the battery life, extra effort has been put in the design of the ASIC

to ensure minimum current consumption during battery mode operation. Therefore, no miscounts occur even in the absence of external power supply.

Features

- 39-bit resolution: 16-bit battery backup multi-turn and 23-bit optical single-turn
- Built-in communication protocol (option): BiSS C mode, SSI mode and RS-485 half-duplex
- Overall encoder outer diameter $\varnothing 37$ mm and typical mounting height 28 mm
- Supporting standard hollow taper shaft, short hollow taper shaft and $\frac{1}{4}$ inch, 6-mm and 8-mm diameter of the hollow blind shaft options.

Benefits

- High resolution with higher measurement accuracy and better speed ripple control.
- Immediate position detection upon power up without the need of system homing.
- Hollow taper shaft design for China Servo motor market.
- Short hollow taper shaft option for low height application.
- Small OD and low height for ease of integration to small size motor.

Applications

- Robotics
- Factory automation
- CNC machine tool

NOTE Broadcom encoders are not recommended for use in safety critical applications, e.g., ABS braking systems, power steering, life support systems, and critical care medical equipment. Contact a sales representative if more clarification is needed.

Product Specifications

Electrical Specifications

| Parameter | Conditions | Min. | Typ. | Max. | Unit |
|---------------------------------------|---------------------------|------|------|-----------------------|--------------------|
| Current Consumption | Without load, Tamb = 25°C | — | 115 | — | mA |
| Supply Voltage | — | 4.5 | 5 | 5.5 | V |
| Electrically Permissible Speed | — | — | — | 6,000 | min ⁻¹ |
| Electrically Permissible Acceleration | Normal mode | — | — | 8.0 x 10 ⁴ | rad/s ² |
| | Battery mode | — | — | 4.0 x 10 ⁴ | |
| External Battery Supply Voltage | — | — | 3.6 | 4.5 | V |
| Battery Mode Current Consumption | Tamb = 25°C | — | 95 | — | μA |

Note:

Normal mode: Encoder operates on encoder main power supply.

Battery mode: Encoder operates in "OFF" State, while multi-turn data is tracked by battery circuitry

Mechanical Specifications

| Parameter | Conditions | Min. | Typ. | Max. | Unit |
|------------------------------|--|------|------|------------------------|-------------------|
| System Accuracy | With electrical correction, Tamb = 25°C | — | ±80 | — | Arc-sec |
| Mechanical Permissible Speed | — | — | — | 6,000 | min ⁻¹ |
| Shaft Radial Play | — | — | — | ±0.05 | mm |
| Shaft Axial Play | — | — | — | ±0.1 | mm |
| Starting Torque | Tamb = 25°C | — | — | 9.8 x 10 ⁻³ | N.m |

Environmental Specifications

| Parameter | Conditions | Min. | Typ. | Max. | Unit |
|--|--------------------|------|------|-------------------------|------|
| Storage Temperature | — | -20 | — | 105 | °C |
| Operating Temperature | — | -20 | — | 105 | °C |
| Relative Air Humidity (Non-Condensing) | Tamb = 40°C | — | 90 | — | RH% |
| Protection | — | — | IP40 | — | |
| Vibration | Per IEC 60068-2-6 | — | — | 10G; 10~2000 Hz | |
| Shock | Per IEC 60068-2-27 | — | — | 6ms; Half Sine; 200G | |

Encoder Specifications

| Parameter | Remarks |
|---------------------|--|
| Resolution | Single-turn 23-bit (8388607 counts) and Multi-turn 16-bit (65535 counts). |
| Counting Direction | Increase with Counter Clockwise (CCW) shaft rotation, view from coupling end (Figure 1). |
| Initialization Time | 500 ms. |

Figure 1 Shaft Rotation

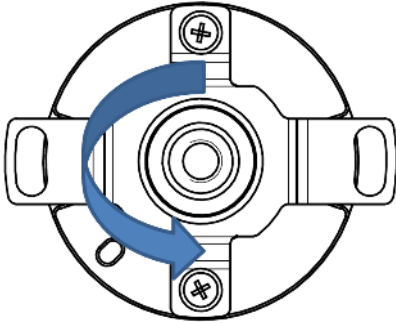

NOTE Exposure to absolute maximum rating conditions for extended periods might affect reliability.

Interface Diagram

The following are examples of the circuit diagram of full-duplex and half-duplex transceiver.

Full-Duplex Transceiver (BiSS C Mode/SSI Mode Protocol)

Figure 2 Circuit Diagram of Full-Duplex Transceiver

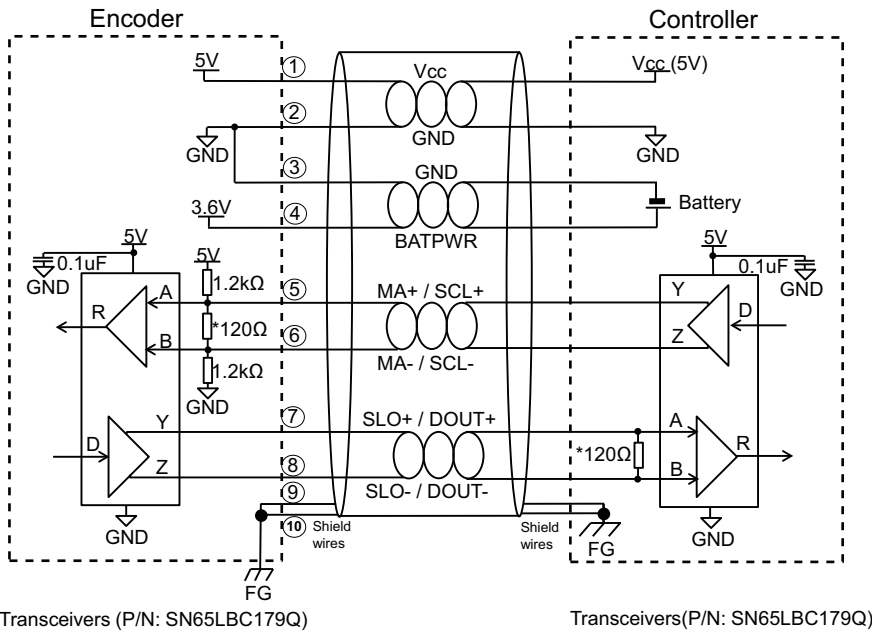

Half-Duplex Transceiver (RS-485 Half-Duplex Protocol)

Figure 3 Circuit Diagram of Half-Duplex Transceiver

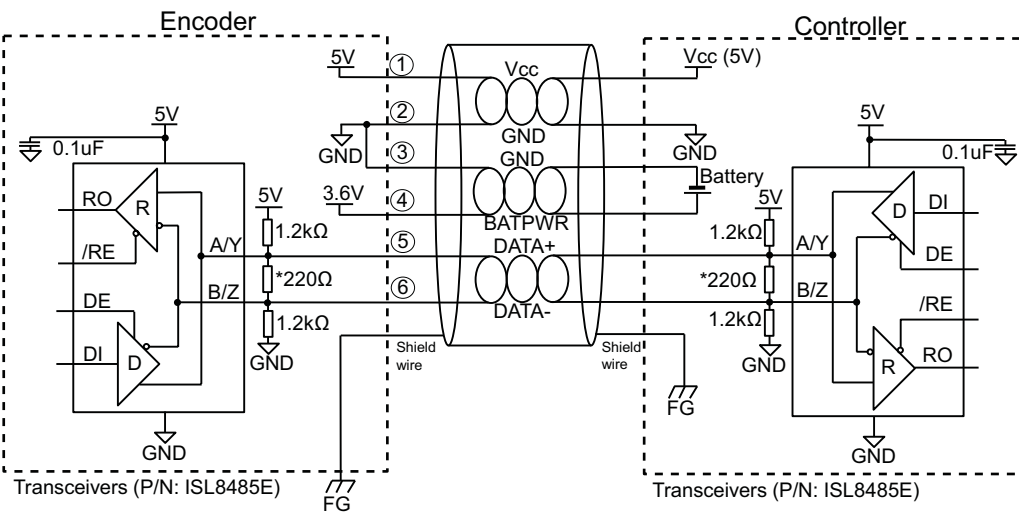

* Termination resistor, 120Ω and 220Ω are recommended but may depend on the characteristic impedance of cable used.

NOTE Connect encoder chassis and cable shield to frame ground (FG) in application for enhanced noise immunity in harsh operating conditions.

Connector Output Assignment

| Pin | AS37-H39B-Bxxx (BiSS-C) (Output: 10-Pin Connector) | AS37-H39B-Sxxx (SSI) (Output: 10-Pin Connector) | AS37-H39B-Kxxx (RS-485 Half-Duplex) (Output: 7-Pin Connector) |
|-----|---|--|--|
| 1 | Vcc, Encoder Supply | Vcc, Encoder Supply | Vcc, Encoder Supply |
| 2 | GND, Ground | GND, Ground | GND, Ground |
| 3 | GND (External Battery) | GND (External Battery) | GND (External Battery) |
| 4 | BATPWR (External Battery) | BATPWR (External Battery) | BATPWR (External Battery) |
| 5 | MA+ | SCL+ | DATA+ |
| 6 | MA- | SCL- | DATA- |
| 7 | SLO+ | DOU+ | Cable Shield, Connect to Chassis |
| 8 | SLO- | DOU- | N/A |
| 9 | Cable Shield, Connect to Chassis | Cable Shield, Connect to Chassis | N/A |
| 10 | Cable Shield, Connect to Chassis | Cable Shield, Connect to Chassis | N/A |

Figure 4 7- Pin Connector Pin Assignment

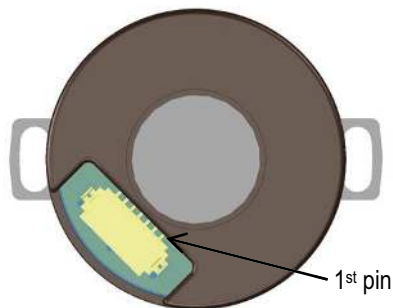
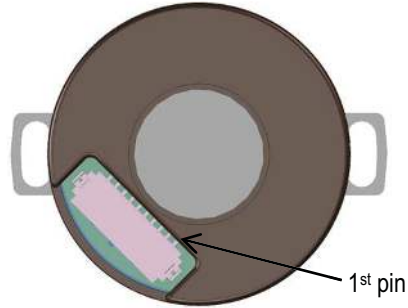

Figure 5 10-Pin Connector Pin Assignment



NOTE Recommended mating connector:

Hirose Part No: DF13-7S-1.25C for 7-pin connector and DF13-10S-1.25C for 10-pin connector (CL No.536-0006-8).

Hirose (Terminal Pin for Wire 26~30AWG): DF13-2630SCF (CL No.536-0300-5).

Mechanical Outline

Standard Hollow Taper Shaft Option ($\Phi 9$ to $\Phi 7.5$ mm; 1:10)

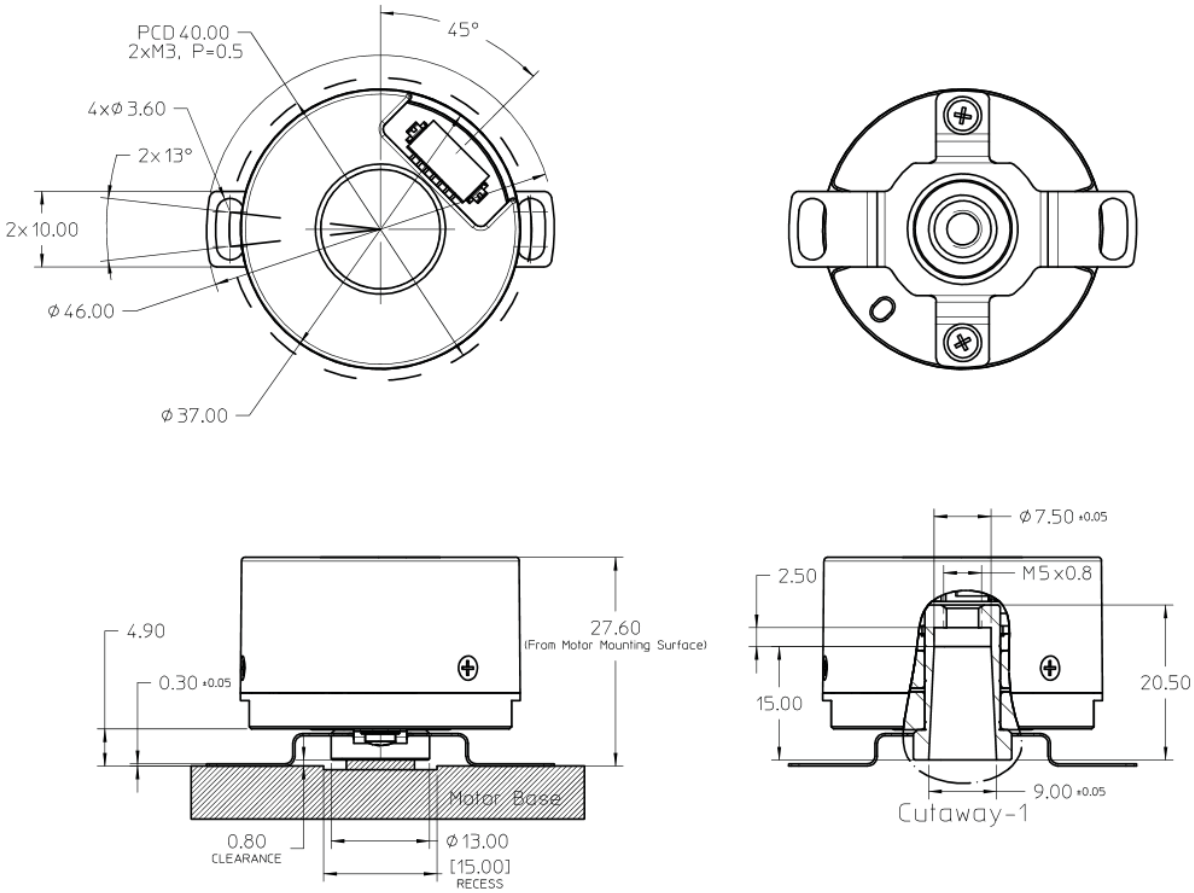

Recommended Shaft and Mounting Requirement

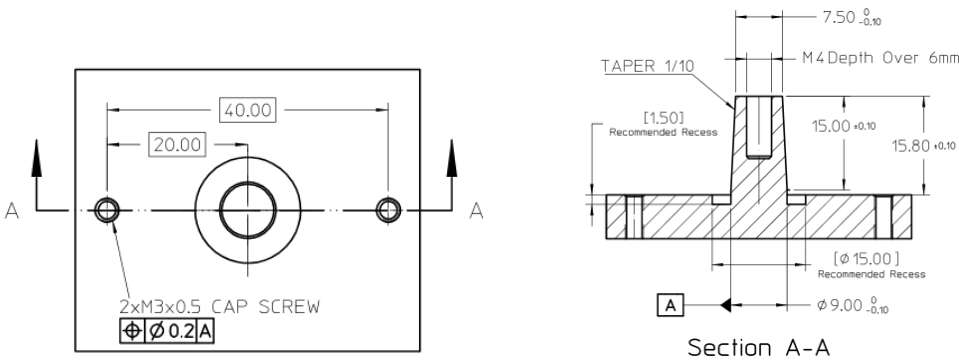

Notes:

Dimensions are in millimeters.

3rd angle projection.

Unless otherwise specified, all tolerances are within ± 0.5 mm.

Recommended to have a recess on motor mounting surface to prevent encoder shaft interference with motor base.

Short Hollow Taper Shaft Option ($\Phi 9$ to $\Phi 7.65$ mm; 1:10)

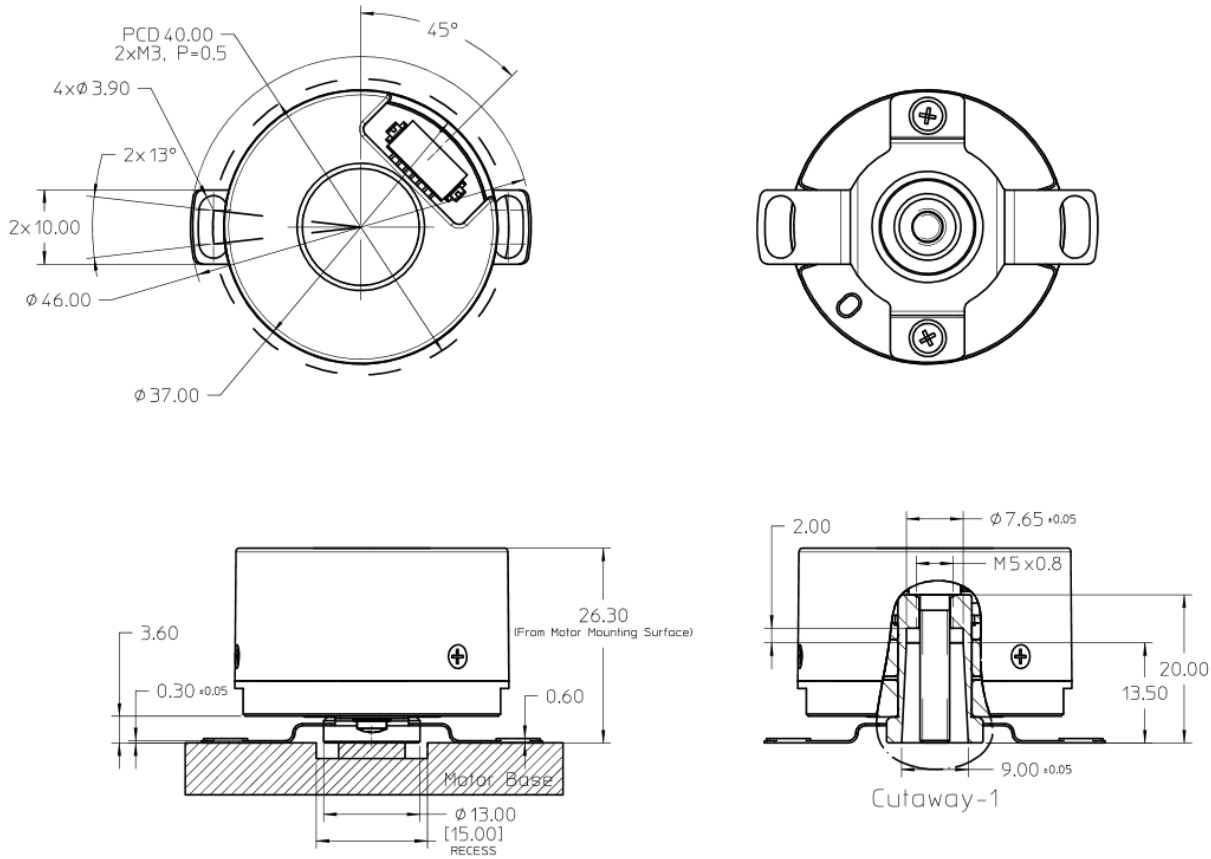

Recommended Shaft and Mounting Requirement

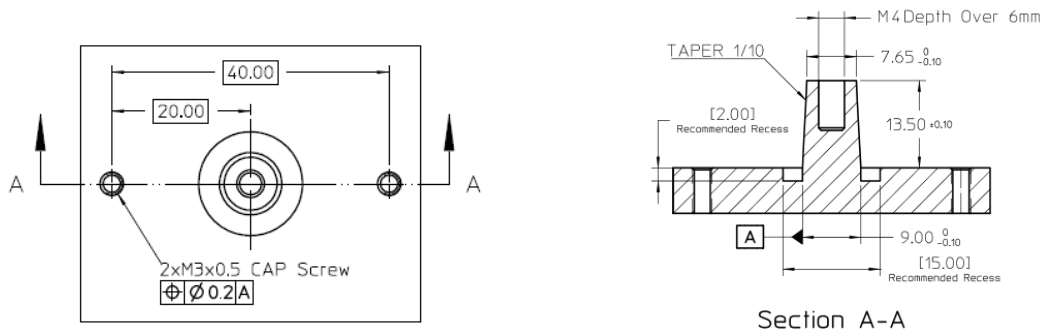

Notes:

Dimensions are in millimeters.

3rd angle projection.

Unless otherwise specified, all tolerances are within ± 0.5 mm.

Recommended to have a recess on motor mounting surface to prevent encoder shaft interference with motor base.

Hollow Blind Shaft Option (Φ8 mm)

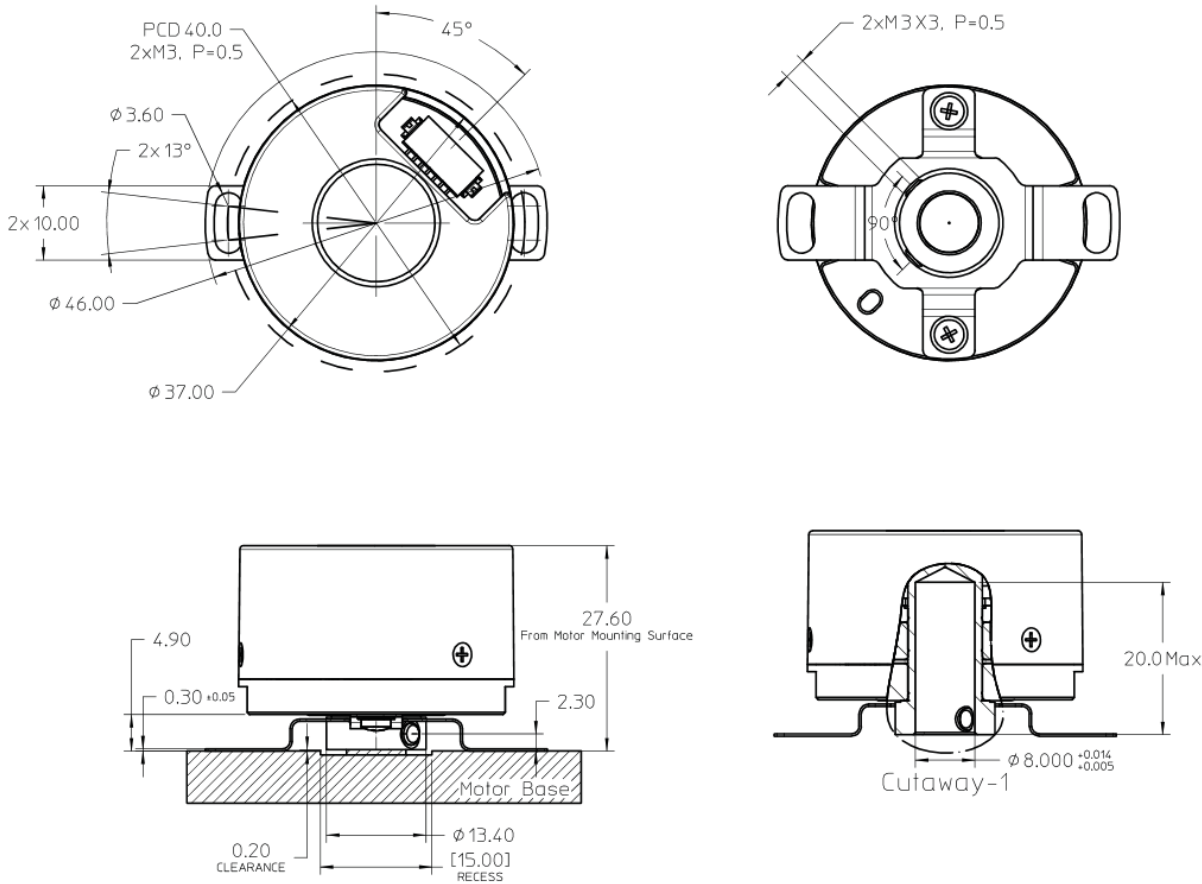

Recommended Shaft and Mounting Requirement

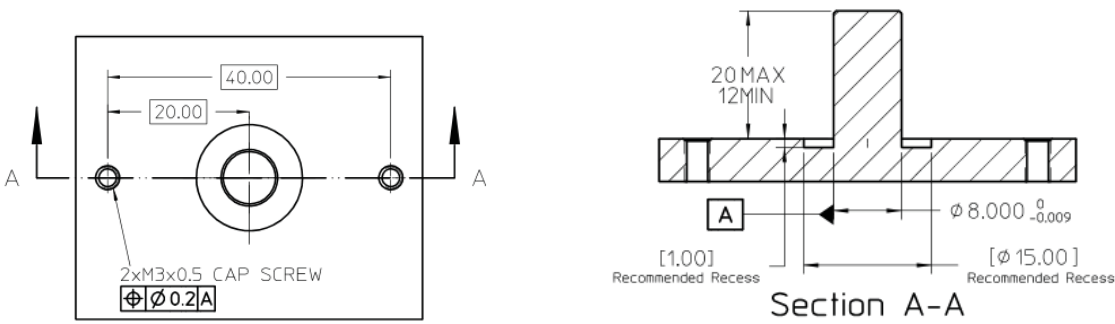

- Notes:
- Dimensions are in millimeters.
 - 3rd angle projection.
 - Unless otherwise specified, all tolerances are within ± 0.5 mm.
 - Recommended to have a recess on motor mounting surface to prevent encoder shaft interference with motor base.

Ordering Information

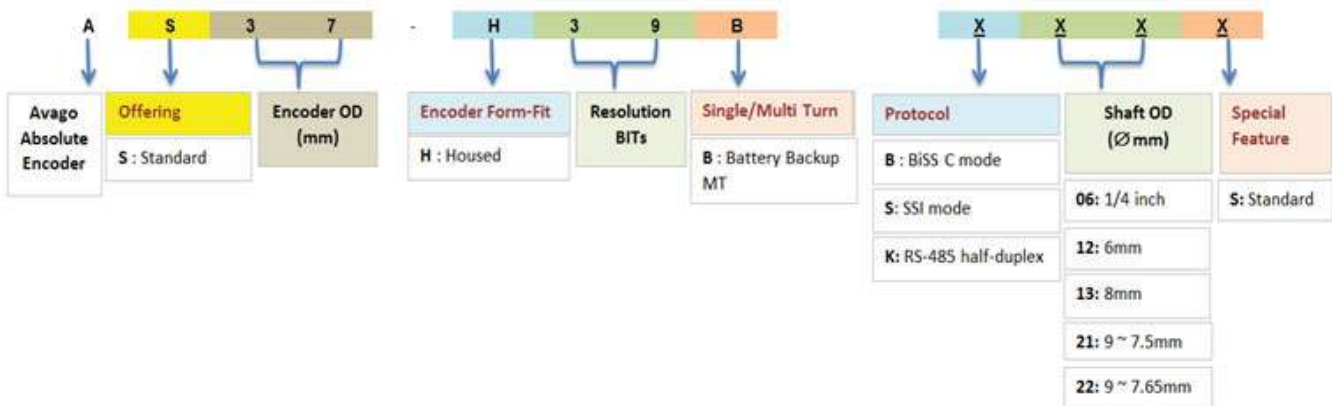

NOTE Refer to the factory for sample order and lead time.

For product information and a complete list of distributors, please go to our web site: www.broadcom.com.

Broadcom, the pulse logo, Connecting everything, Avago Technologies, Avago, and the A logo are among the trademarks of Broadcom in the United States, certain other countries and/or the EU.

Copyright © 2017 Broadcom. All Rights Reserved.

The term "Broadcom" refers to Broadcom Limited and/or its subsidiaries. For more information, please visit www.broadcom.com.

Broadcom reserves the right to make changes without further notice to any products or data herein to improve reliability, function, or design.

Information furnished by Broadcom is believed to be accurate and reliable. However, Broadcom does not assume any liability arising out of the application or use of this information, nor the application or use of any product or circuit described herein, neither does it convey any license under its patent rights nor the rights of others.

AS37-H39B-DS100 – March 31, 2017

