

Rev	AWO #	Description	Date	Appr
-		RELEASED	12/30/04	
A		REDESIGN	9/1/05	
B		REDESIGN	12/28/05	
C		Added Contact Capacitance	5/11/09	
D		UPDATED DRAWING	12/13/17	HR/YC

APPROVED: _____
DATE: _____ TITLE: _____

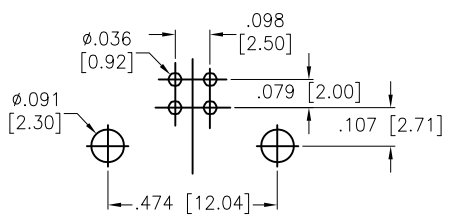
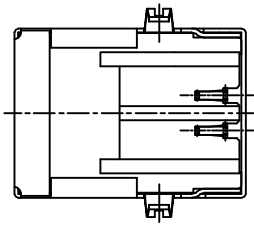
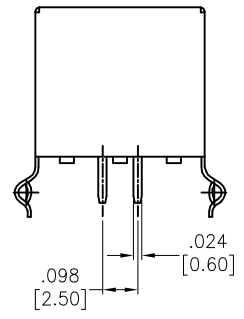
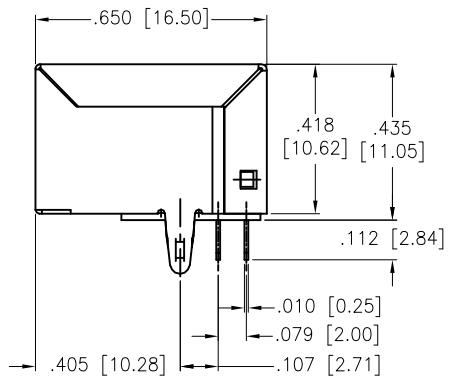
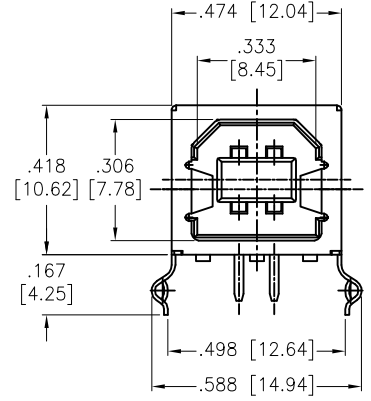
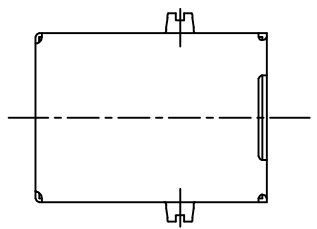

RECOMMENDED PCB LAYOUT

SPECIFICATIONS:
Material:
 Insulator: PBT, rated UL 94V-0
 Insulator color: Black
 Contacts: Brass
 Shell: Brass, Nickel plated
Plating:
 Gold Flash over Nickel underplate on contact area
Electrical:
 Voltage rating: 30 V
 Current rating: 1.5 Amp @ 250 VAC
 Contact resistance: 30 mohms max
 Insulation resistance: 1,000 Mohms min
 Dielectric withstanding voltage: 500 VAC
Temperature Rating:
 -20°C to +60°C
Environmental:
 Lead free, RoHS compliant



UNLESS OTHERWISE SPECIFIED ALL DIMENSIONS ARE INCHES [MM] TOLERANCES: EXCEPT AS NOTED	
INCHES	HOLES
.X ± .10	Ø.X ± .10
.XX ± .020	Ø.XX ± .015
.XXX ± .015	Ø.XXX ± .010
APPROVALS	
DRAWN	DATE
SS	11/29/05
CHECKED	
APPROVED	

	909 Rahway Avenue, Union, NJ 07083 Phone: 908-687-5000 Fax: 908-687-5710	
	TITLE USB, TYPE B, SINGLE PORT, RIGHT ANGLE, THRU-HOLE, GOLD FLASH	
SIZE X	PART NO. USB-B-S-RA	REV. D
REF: S00005C	SCALE: NTS	SHEET 1 OF 1

6 5 4 3 2 1

D
C
B
A

D
C
B
A

6 5 4 3 2 1