

## GENERAL DESCRIPTION

The ICS8535I-01 is a low skew, high performance 1-to-4 LVCMOS/LVTTL-to-3.3V LVPECL fanout buffer. The ICS8535I-01 has two single ended clock inputs. the single ended clock input accepts LVCMOS or LVTTL input levels and translate them to 3.3V LVPECL levels. The clock enable is internally synchronized to eliminate runt clock pulses on the output during asynchronous assertion/deassertion of the clock enable pin.

Guaranteed output and part-to-part skew characteristics make the ICS8535I-01 ideal for those applications demanding well defined performance and repeatability.

## FEATURES

- Four differential 3.3V LVPECL outputs
- Selectable CLK0 or CLK1 inputs for redundant and multiple frequency fanout applications
- CLK0 or CLK1 can accept the following input levels: LVCMOS or LVTTL
- Maximum output frequency: 266MHz
- Translates LVCMOS and LVTTL levels to 3.3V LVPECL levels
- Output skew: 30ps (maximum)
- Part-to-part skew: 250ps (maximum)
- Propagation delay: 1.9ns (maximum)
- Jitter, RMS: < 0.09ps (typical)
- 3.3V operating supply
- -40°C to 85°C ambient operating temperature
- Available in both standard and lead-free RoHS compliant packages

## BLOCK DIAGRAM

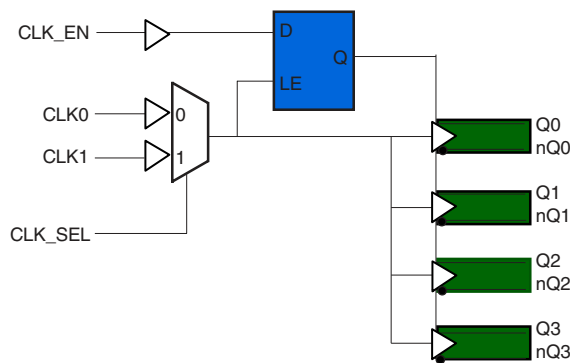

## PIN ASSIGNMENT

VEE	1	20	Q0
CLK_EN	2	19	nQ0
CLK_SEL	3	18	Vcc
CLK0	4	17	Q1
nc	5	16	nQ1
CLK1	6	15	Q2
nc	7	14	nQ2
nc	8	13	Vcc
nc	9	12	Q3
Vcc	10	11	nQ3

### ICS8535I-01 20-Lead TSSOP

4.4mm x 6.5mm x 0.92mm body package

**G Package**  
Top View

**TABLE 1. PIN DESCRIPTIONS**

Number	Name	Type		Description
1	V <sub>EE</sub>	Power		Negative supply pin.
2	CLK_EN	Input	Pullup	Synchronizing clock enable. When HIGH, clock outputs follow clock input. When LOW, Q outputs are forced low, nQ outputs are forced high. LVCMOS / LVTTL interface levels.
3	CLK_SEL	Input	Pulldown	Clock select input. When HIGH, selects CLK1 input. When LOW, selects CLK0 input. LVCMOS / LVTTL interface levels.
4	CLK0	Input	Pulldown	LVCMOS / LVTTL clock input.
6	CLK1	Input	Pulldown	LVCMOS / LVTTL clock input.
5, 7, 8, 9	nc	Unused		No connect.
10, 13, 18	V <sub>CC</sub>	Power		Positive supply pins.
11, 12	nQ3, Q3	Output		Differential output pair. LVPECL interface levels.
14, 15	nQ2, Q2	Output		Differential output pair. LVPECL interface levels.
16, 17	nQ1, Q1	Output		Differential output pair. LVPECL interface levels.
19, 20	nQ0, Q0	Output		Differential output pair. LVPECL interface levels.

NOTE: *Pullup* and *Pulldown* refer to internal input resistors. See Table 2, Pin Characteristics, for typical values.

**TABLE 2. PIN CHARACTERISTICS**

Symbol	Parameter	Test Conditions	Minimum	Typical	Maximum	Units
C <sub>IN</sub>	Input Capacitance			4		pF
R <sub>PULLUP</sub>	Input Pullup Resistor			51		kΩ
R <sub>PULLDOWN</sub>	Input Pulldown Resistor			51		kΩ

TABLE 3A. CONTROL INPUT FUNCTION TABLE

Inputs			Outputs	
CLK_EN	CLK_SEL	Selected Source	Q0:Q3	nQ0:nQ3
0	0	CLK0	Disabled; LOW	Disabled; HIGH
0	1	CLK1	Disabled; LOW	Disabled; HIGH
1	0	CLK0	Enabled	Enabled
1	1	CLK1	Enabled	Enabled

After CLK\_EN switches, the clock outputs are disabled or enabled following a rising and falling input clock edge as show in Figure 1. In the active mode, the state of the outputs are a function of the CLK0 and CLK1 inputs as described in Table 3B.

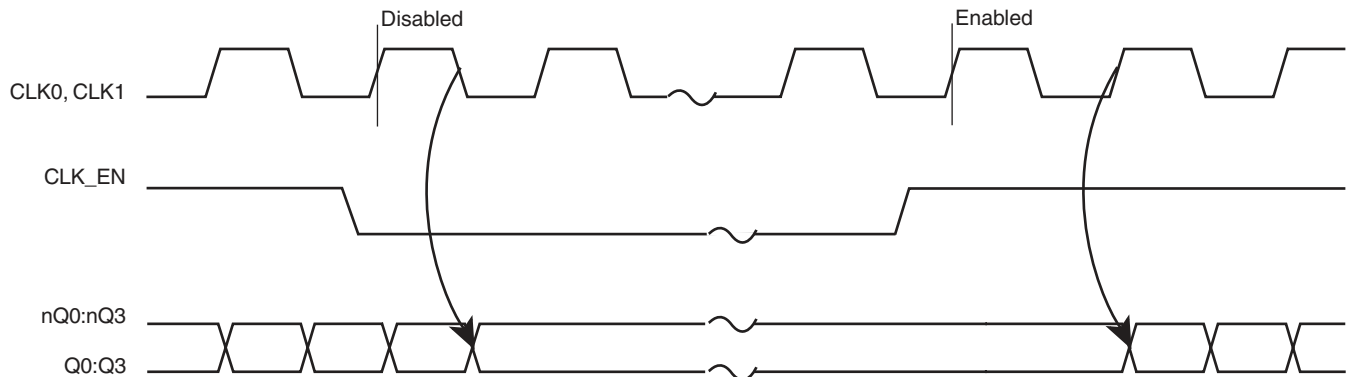

FIGURE 1. CLK\_EN TIMING DIAGRAM

TABLE 3B. CLOCK INPUT FUNCTION TABLE

Inputs	Outputs	
CLK0 or CLK1	Q0:Q3	nQ0:nQ3
0	LOW	HIGH
1	HIGH	LOW

**ABSOLUTE MAXIMUM RATINGS**

Supply Voltage, $V_{CC}$	4.6V
Inputs, $V_I$	-0.5V to $V_{CC} + 0.5V$
Outputs, $I_O$	
Continuous Current	50mA
Surge Current	100mA
Package Thermal Impedance, $\theta_{JA}$	73.2°C/W (0 lfpm)
Storage Temperature, $T_{STG}$	-65°C to 150°C

NOTE: Stresses beyond those listed under Absolute Maximum Ratings may cause permanent damage to the device. These ratings are stress specifications only. Functional operation of product at these conditions or any conditions beyond those listed in the *DC Characteristics* or *AC Characteristics* is not implied. Exposure to absolute maximum rating conditions for extended periods may affect product reliability.

**TABLE 4A. POWER SUPPLY DC CHARACTERISTICS,  $V_{CC} = 3.3V \pm 5\%$ ,  $T_A = -40^\circ C$  TO  $85^\circ C$**

Symbol	Parameter	Test Conditions	Minimum	Typical	Maximum	Units
$V_{CC}$	Positive Supply Voltage		3.135	3.3	3.465	V
$I_{EE}$	Power Supply Current				55	mA

**TABLE 4B. LVCMOS / LVTTL DC CHARACTERISTICS,  $V_{CC} = 3.3V \pm 5\%$ ,  $T_A = -40^\circ C$  TO  $85^\circ C$**

Symbol	Parameter	Test Conditions	Minimum	Typical	Maximum	Units
$V_{IH}$	Input High Voltage	CLK0, CLK1	2		$V_{CC} + 0.3$	V
		CLK_EN, CLK_SEL	2		$V_{CC} + 0.3$	V
$V_{IL}$	Input Low Voltage	CLK0, CLK1	-0.3		1.3	V
		CLK_EN, CLK_SEL	-0.3		0.8	V
$I_{IH}$	Input High Current	CLK0, CLK1, CLK_SEL	$V_{IN} = V_{CC} = 3.465V$		150	$\mu A$
		CLK_EN	$V_{IN} = V_{CC} = 3.465V$		5	$\mu A$
$I_{IL}$	Input Low Current	CLK0, CLK1, CLK_SEL	$V_{IN} = 0V, V_{CC} = 3.465V$	-5		$\mu A$
		CLK_EN	$V_{IN} = 0V, V_{CC} = 3.465V$	-150		$\mu A$

**TABLE 4C. LVPECL DC CHARACTERISTICS,  $V_{CC} = 3.3V \pm 5\%$ ,  $T_A = -40^\circ C$  TO  $85^\circ C$**

Symbol	Parameter	Test Conditions	Minimum	Typical	Maximum	Units
$V_{OH}$	Output High Voltage; NOTE 1		$V_{CC} - 1.4$		$V_{CC} - 0.9$	V
$V_{OL}$	Output Low Voltage; NOTE 1		$V_{CC} - 2.0$		$V_{CC} - 1.7$	V
$V_{SWING}$	Peak-to-Peak Output Voltage Swing		0.6		1.0	V

NOTE 1: Outputs terminated with  $50\Omega$  to  $V_{CC} - 2V$ .

**TABLE 5. AC CHARACTERISTICS,  $V_{CC} = 3.3V \pm 5\%$ ,  $T_A = -40^\circ C$  TO  $85^\circ C$**

Symbol	Parameter	Test Conditions	Minimum	Typical	Maximum	Units
$f_{MAX}$	Output Frequency				266	MHz
$t_{PD}$	Propagation Delay; NOTE 1	$f \leq 266\text{MHz}$	1.0		1.9	ns
$tsk(o)$	Output Skew; NOTE 2, 4				30	ps
$tsk(pp)$	Part-to-Part Skew; NOTE 3, 4				250	ps
$f_{jit}$	Buffer Additive Phase Jitter, RMS; refer to Additive Phase Jitter section			0.09		ps
$t_R / t_F$	Output Rise/Fall Time	20% to 80% @ 50MHz	300		700	ps
odc	Output Duty Cycle		48	50	52	%

All parameters measured at 266MHz unless noted otherwise.

The cycle-to-cycle jitter on the input will equal the jitter on the output. The part does not add jitter.

NOTE 1: Measured from the  $V_{CC}/2$  of the input to the differential output crossing point.

NOTE 2: Defined as skew between outputs at the same supply voltage and with equal load conditions.

Measured at the output differential cross points.

NOTE 3: Defined as skew between outputs on different devices operating at the same supply voltages and with equal load conditions. Using the same type of inputs on each device, the outputs are measured at the differential cross points.

NOTE 4: This parameter is defined in accordance with JEDEC Standard 65.

### ADDITIVE PHASE JITTER

The spectral purity in a band at a specific offset from the fundamental compared to the power of the fundamental is called the **dBc Phase Noise**. This value is normally expressed using a Phase noise plot and is most often the specified plot in many applications. Phase noise is defined as the ratio of the noise power present in a 1Hz band at a specified offset from the fundamental frequency to the power value of the fundamental. This ratio is expressed in decibels (dBm) or a ratio of the power

in the 1Hz band to the power in the fundamental. When the required offset is specified, the phase noise is called a **dBc** value, which simply means dBm at a specified offset from the fundamental. By investigating jitter in the frequency domain, we get a better understanding of its effects on the desired application over the entire time record of the signal. It is mathematically possible to calculate an expected bit error rate given a phase noise plot.

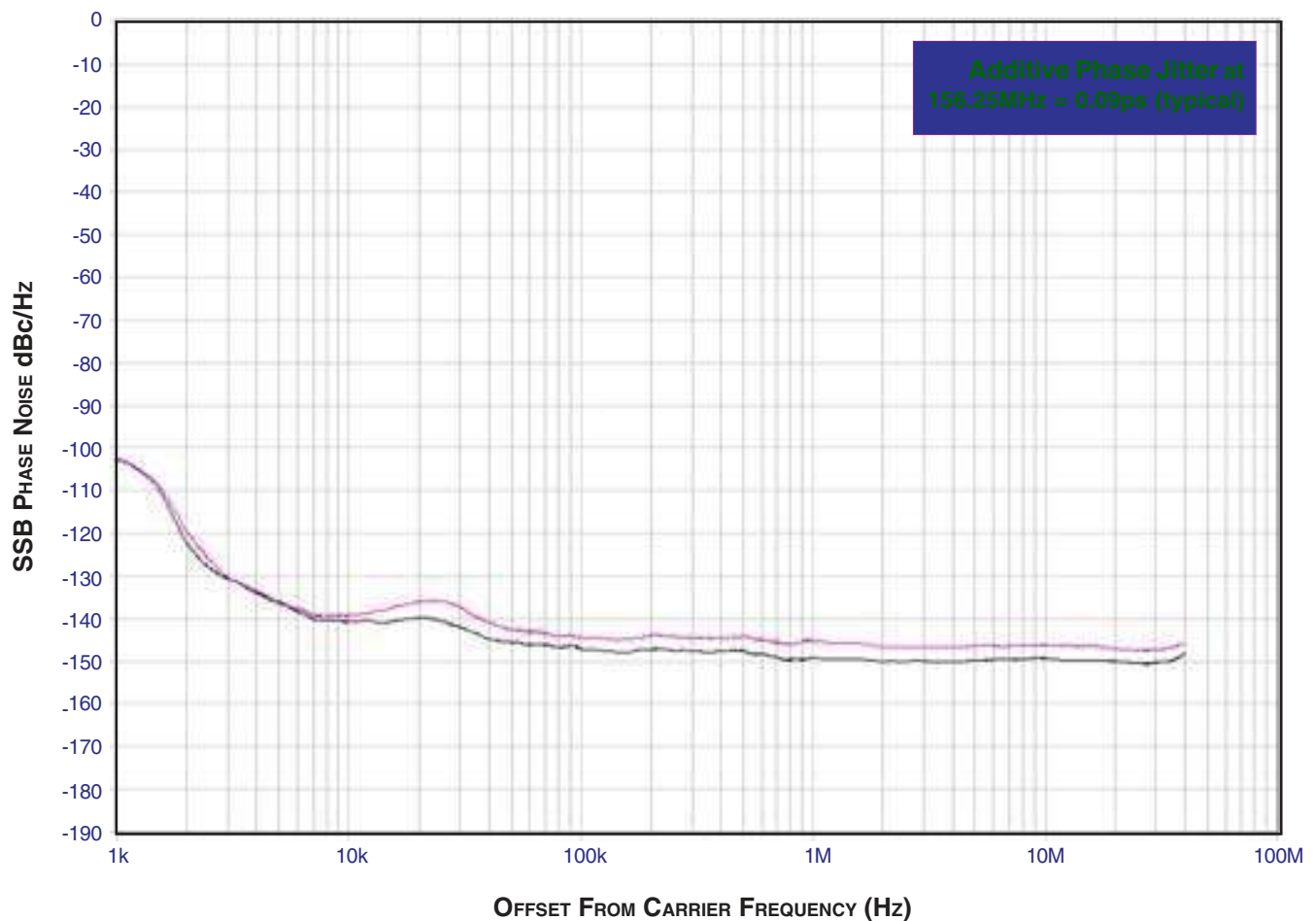

As with most timing specifications, phase noise measurements have issues. The primary issue relates to the limitations of the equipment. Often the noise floor of the equipment is higher than the noise floor of the device. This is illustrated above. The

device meets the noise floor of what is shown, but can actually be lower. The phase noise is dependant on the input source and measurement equipment.

PARAMETER MEASUREMENT INFORMATION

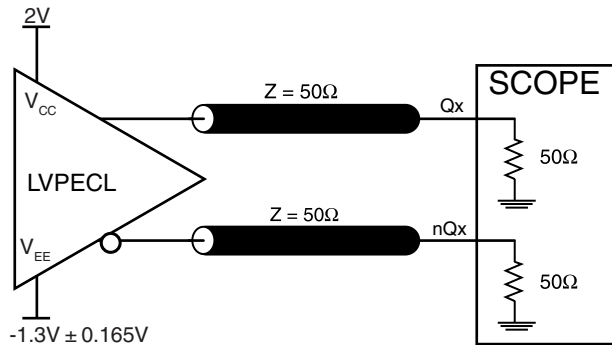

3.3V OUTPUT LOAD AC TEST CIRCUIT

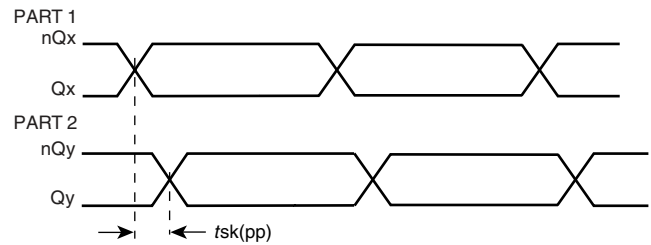

PART-TO-PART SKEW

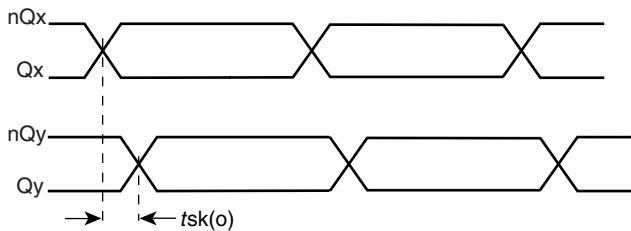

OUTPUT SKEW

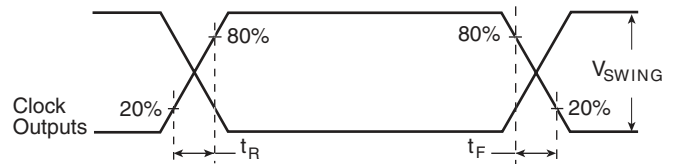

OUTPUT RISE/FALL TIME

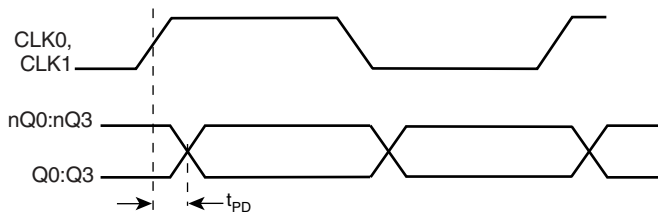

PROPAGATION DELAY

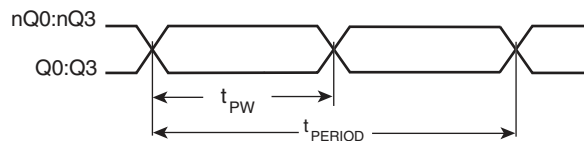

$$odc = \frac{t_{PW}}{t_{PERIOD}} \times 100\%$$

OUTPUT DUTY CYCLE/ PULSE WIDTH/PERIOD

## APPLICATION INFORMATION

### RECOMMENDATIONS FOR UNUSED INPUT AND OUTPUT PINS

#### INPUTS:

##### CLK INPUT:

For applications not requiring the use of a clock input, it can be left floating. Though not required, but for additional protection, a 1kΩ resistor can be tied from the CLK input to ground.

##### LVCMOS CONTROL PINS:

All control pins have internal pull-ups or pull-downs; additional resistance is not required but can be added for additional protection. A 1kΩ resistor can be used.

#### OUTPUTS:

##### LVPECL OUTPUT:

All unused LVPECL outputs can be left floating. We recommend that there is no trace attached. Both sides of the differential output pair should either be left floating or terminated.

### TERMINATION FOR LVPECL OUTPUTS

The clock layout topology shown below is a typical termination for LVPECL outputs. The two different layouts mentioned are recommended only as guidelines.

FOUT and nFOUT are low impedance follower outputs that generate ECL/LVPECL compatible outputs. Therefore, terminating resistors (DC current path to ground) or current sources must be used for functionality. These outputs are designed to

drive 50Ω transmission lines. Matched impedance techniques should be used to maximize operating frequency and minimize signal distortion. *Figures 2A and 2B* show two different layouts which are recommended only as guidelines. Other suitable clock layouts may exist and it would be recommended that the board designers simulate to guarantee compatibility across all printed circuit and clock component process variations.

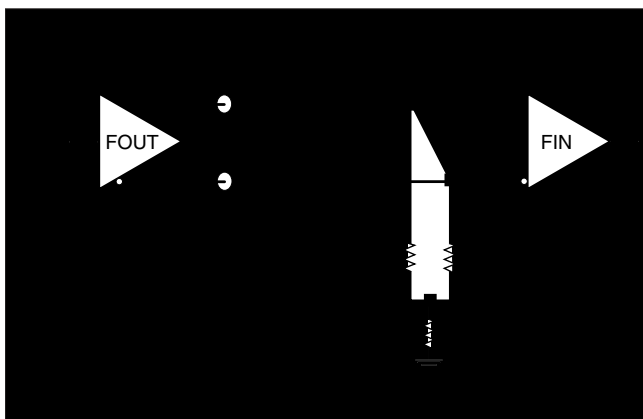

FIGURE 2A. LVPECL OUTPUT TERMINATION

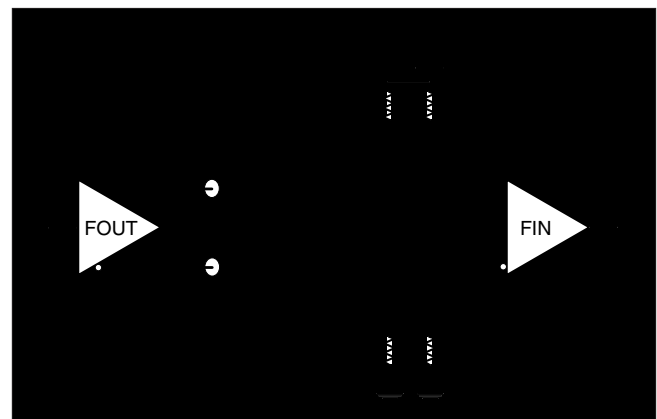

FIGURE 2B. LVPECL OUTPUT TERMINATION



**SCHEMATIC EXAMPLE**

Figure 3 shows a schematic example of the ICS8535I-01. In this example, the CLK0 input is selected. The decoupling ca-

pacitors should be physically located near the power pin. For ICS8535I-01, the unused clock outputs can be left floating.

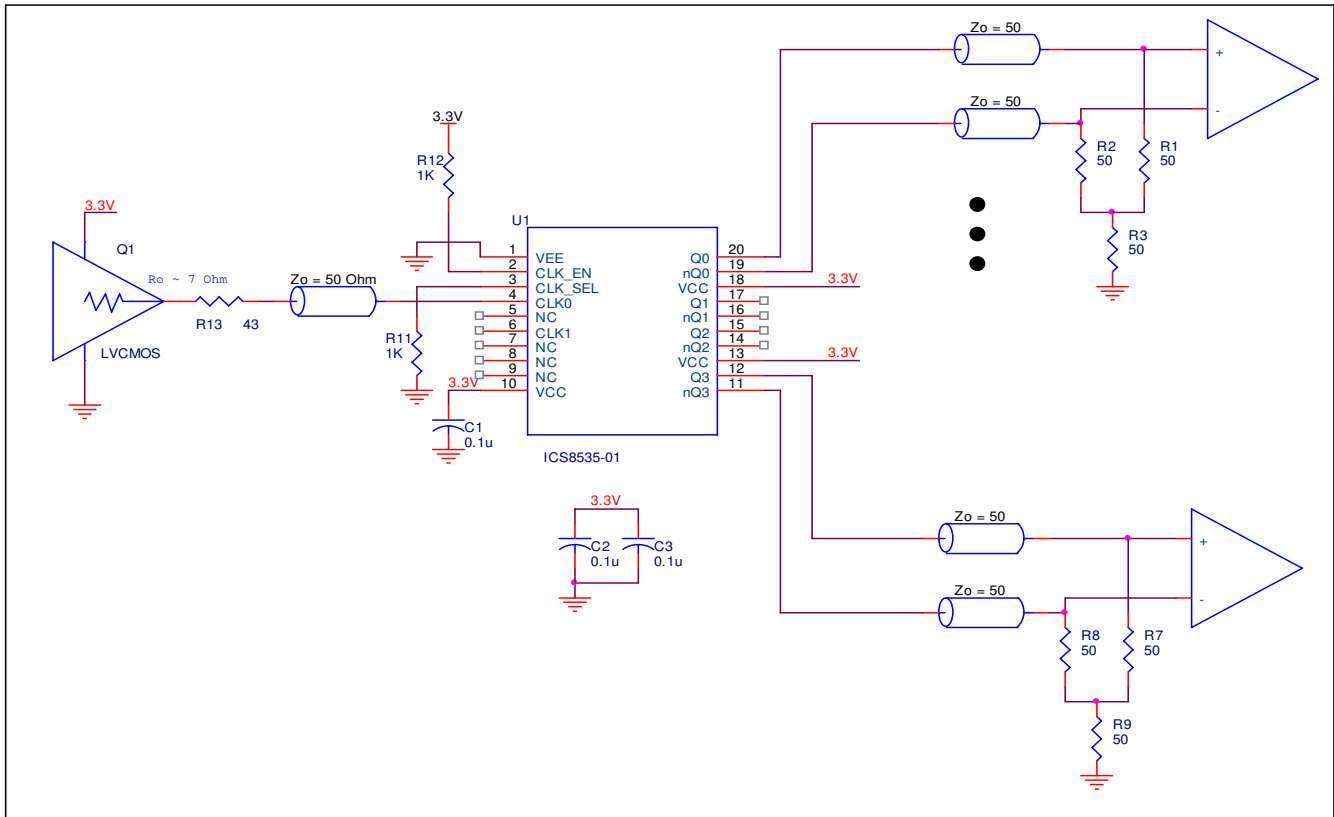

**FIGURE 3. ICS8535I-01 LVPECL BUFFER SCHEMATIC EXAMPLE**

## POWER CONSIDERATIONS

This section provides information on power dissipation and junction temperature for the ICS85351-01. Equations and example calculations are also provided.

### 1. Power Dissipation.

The total power dissipation for the ICS85351-01 is the sum of the core power plus the power dissipated in the load(s). The following is the power dissipation for  $V_{CC} = 3.3V + 5\% = 3.465V$ , which gives worst case results.

**NOTE:** Please refer to Section 3 for details on calculating power dissipated in the load.

- Power (core)<sub>MAX</sub> =  $V_{CC\_MAX} * I_{EE\_MAX} = 3.465V * 55mA = 190.6mW$
- Power (outputs)<sub>MAX</sub> = **30mW/Loaded Output pair**  
If all outputs are loaded, the total power is  $4 * 30mW = 120mW$

**Total Power**<sub>MAX</sub> (3.465V, with all outputs switching) =  $190.6mW + 120mW = 310.6mW$

### 2. Junction Temperature.

Junction temperature, T<sub>j</sub>, is the temperature at the junction of the bond wire and bond pad and directly affects the reliability of the device. The maximum recommended junction temperature for the devices is 125°C.

The equation for T<sub>j</sub> is as follows:  $T_j = \theta_{JA} * Pd\_total + T_A$

T<sub>j</sub> = Junction Temperature

$\theta_{JA}$  = Junction-to-Ambient Thermal Resistance

Pd<sub>total</sub> = Total Device Power Dissipation (example calculation is in section 1 above)

T<sub>A</sub> = Ambient Temperature

In order to calculate junction temperature, the appropriate junction-to-ambient thermal resistance  $\theta_{JA}$  must be used. Assuming a moderate air flow of 200 linear feet per minute and a multi-layer board, the appropriate value is 66.6°C/W per Table 6 below.

Therefore, T<sub>j</sub> for an ambient temperature of 85°C with all outputs switching is:

$85°C + 0.311W * 66.6°C/W = 105.7°C$ . This is well below the limit of 125°C.

This calculation is only an example, and the T<sub>j</sub> will obviously vary depending on the number of outputs that are loaded, supply voltage, air flow, and the type of board (single layer or multi-layer).

**TABLE 6. THERMAL RESISTANCE  $\theta_{JA}$  FOR 20-PIN TSSOP, FORCED CONVECTION**

$\theta_{JA}$ by Velocity (Linear Feet per Minute)			
	0	200	500
Single-Layer PCB, JEDEC Standard Test Boards	114.5°C/W	98.0°C/W	88.0°C/W
Multi-Layer PCB, JEDEC Standard Test Boards	73.2°C/W	66.6°C/W	63.5°C/W

**NOTE:** Most modern PCB designs use multi-layered boards. The data in the second row pertains to most designs.

3. Calculations and Equations.

The purpose of this section is to derive the power dissipated into the load.

LVPECL output driver circuit and termination are shown in *Figure 4*.

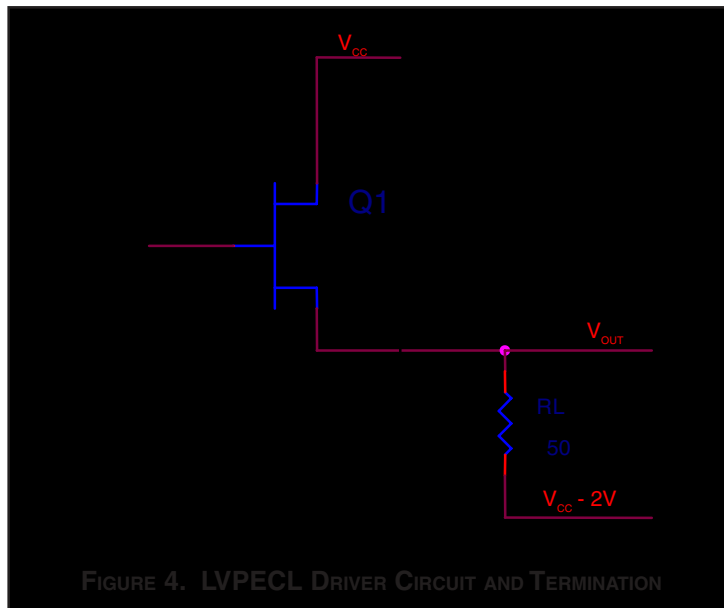

To calculate worst case power dissipation into the load, use the following equations which assume a 50Ω load, and a termination voltage of  $V_{CC} - 2V$ .

- For logic high,  $V_{OUT} = V_{OH\_MAX} = V_{CC\_MAX} - 0.9V$   
 $(V_{CC\_MAX} - V_{OH\_MAX}) = 0.9V$
- For logic low,  $V_{OUT} = V_{OL\_MAX} = V_{CC\_MAX} - 1.7V$   
 $(V_{CC\_MAX} - V_{OL\_MAX}) = 1.7V$

$Pd\_H$  is power dissipation when the output drives high.  
 $Pd\_L$  is the power dissipation when the output drives low.

$$Pd\_H = [(V_{OH\_MAX} - (V_{CC\_MAX} - 2V))/R_L] * (V_{CC\_MAX} - V_{OH\_MAX}) = [(2V - (V_{CC\_MAX} - V_{OH\_MAX}))/R_L] * (V_{CC\_MAX} - V_{OH\_MAX}) = [(2V - 0.9V)/50\Omega] * 0.9V = \mathbf{19.8mW}$$

$$Pd\_L = [(V_{OL\_MAX} - (V_{CC\_MAX} - 2V))/R_L] * (V_{CC\_MAX} - V_{OL\_MAX}) = [(2V - (V_{CC\_MAX} - V_{OL\_MAX}))/R_L] * (V_{CC\_MAX} - V_{OL\_MAX}) = [(2V - 1.7V)/50\Omega] * 1.7V = \mathbf{10.2mW}$$

Total Power Dissipation per output pair =  $Pd\_H + Pd\_L = \mathbf{30mW}$

## RELIABILITY INFORMATION

TABLE 7.  $\theta_{JA}$  vs. AIR FLOW TABLE FOR 20 LEAD TSSOP

$\theta_{JA}$ by Velocity (Linear Feet per Minute)			
	0	200	500
Single-Layer PCB, JEDEC Standard Test Boards	114.5°C/W	98.0°C/W	88.0°C/W
Multi-Layer PCB, JEDEC Standard Test Boards	73.2°C/W	66.6°C/W	63.5°C/W

**NOTE:** Most modern PCB designs use multi-layered boards. The data in the second row pertains to most designs.

### TRANSISTOR COUNT

The transistor count for ICS8535I-01 is: 412

PACKAGE OUTLINE - G SUFFIX FOR 20 LEAD TSSOP

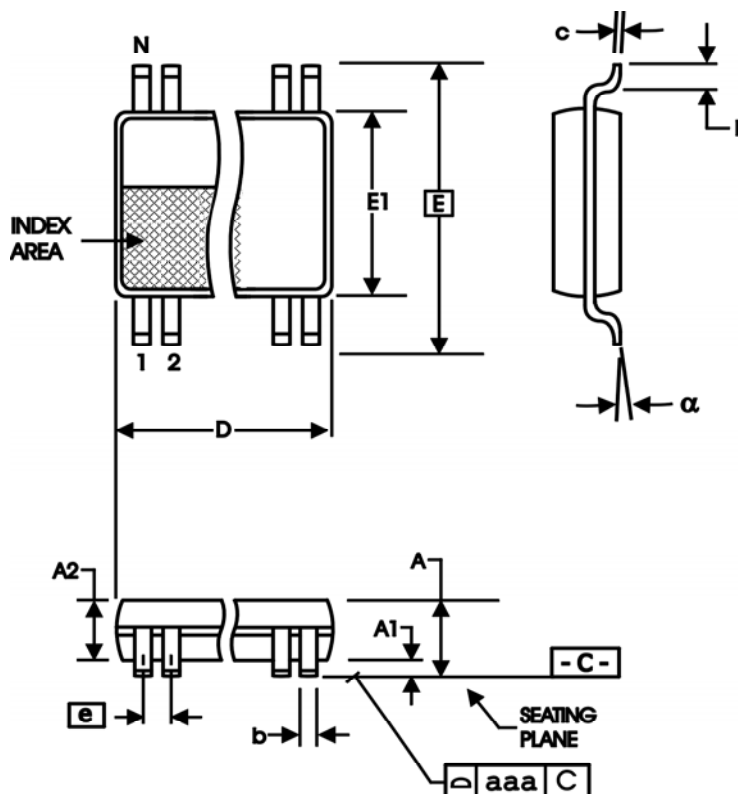

TABLE 8. PACKAGE DIMENSIONS

SYMBOL	Millimeters	
	Minimum	Maximum
N	20	
A	--	1.20
A1	0.05	0.15
A2	0.80	1.05
b	0.19	0.30
c	0.09	0.20
D	6.40	6.60
E	6.40 BASIC	
E1	4.30	4.50
e	0.65 BASIC	
L	0.45	0.75
alpha	0°	8°
aaa	--	0.10

REFERENCE DOCUMENT: JEDEC PUBLICATION 95, MO-153

**TABLE 9. ORDERING INFORMATION**

<b>Part/Order Number</b>	<b>Marking</b>	<b>Package</b>	<b>Shipping Packaging</b>	<b>Temperature</b>
8535AGI-01LF	8535AI01L	20 lead "Lead Free" TSSOP	Tray	-40°C to +85°C
8535AGI-01LFT	8535AI01L	20 lead "Lead Free" TSSOP	2500 Tape and Reel	-40°C to +85°C

NOTE: "LF" suffix to the part number are the PB-free configuration, RoHS compliant

REVISION HISTORY SHEET				
Rev	Table	Page	Description of Change	Date
A	T9	9 14	Added Termination for LVPECL Output section. Revised Marking on Ordering Information Table.	5/29/02
A		6	Output Load Test Circuit - corrected $V_{EE}$ equation to read " $V_{EE} = -0.5V \pm 0.165V$ " from " $V_{EE} = -0.5V \pm 0.135V$ ".	10/4/02
B	T5	5	AC Characteristics table - changed tsk(pp) from 200ps max. to 250ps. max. Update format.	12/16/02
C		8 4	Added Schematic Example in the Application Section. LVPECL Table - changed $V_{SWING}$ 0.85V Max. to 1.0V Max.	1/20/03
D	T2	1	Added RMS Jitter to Features section.	12/4/03
		2	Pin Characteristics Table - changed $C_{IN}$ from 4pF max. to 4pF typical.	
	4	Revised Absolute Maximum Ratings Output.		
	5	AC Characteritsics Table - added RMS Jitter.		
	6	Added Additive Phase Jitter Section.		
T5	8	Revised LVPECL Output Termination diagrams.		
	14	Added "Lead Free" Part/Order Number rows.		
E	T4A	4	Corrected Ambient Operating Temperature range from 0° - 70°C to -40°C - 85°C. Power Supply Current, changed $I_{EE}$ back to 55mA max. from 50mA max.	1/14/04
E	T9	14	Ordering Information Table - corrected temperature range.	6/24/04
E	T9	14	Ordering Information Table - Lead-Free Marking from 8535AGI01L to 8535AI01L..	9/10/04
E	T9	8 14	Added <i>Recommendations for Unused Input and Output Pins</i> Ordering Information Table - corrected marking from ICS8535AGI01 to ICS8535AI-01.	4/21/06
F	T4C	4	LVPECL DC Characteristics Table -corrected $V_{OH}$ max. from $V_{CC} - 1.0V$ to $V_{CC} - 0.9V$ .	4/12/07
		10 - 11	Power Considerations - corrected power dissipation to reflect $V_{OH}$ max in Table 4C.	
F	T9	14 16	Updated datasheet's header/footer with IDT from ICS. Removed ICS prefix from Part/Order Number column. Added Contact Page.	10/4/10
F	T4C	4	Corrected $V_{OH}$ Max from 0.9V to $V_{CC} - 0.9V$	5/28/13





## IMPORTANT NOTICE AND DISCLAIMER

RENESAS ELECTRONICS CORPORATION AND ITS SUBSIDIARIES (“RENESAS”) PROVIDES TECHNICAL SPECIFICATIONS AND RELIABILITY DATA (INCLUDING DATASHEETS), DESIGN RESOURCES (INCLUDING REFERENCE DESIGNS), APPLICATION OR OTHER DESIGN ADVICE, WEB TOOLS, SAFETY INFORMATION, AND OTHER RESOURCES “AS IS” AND WITH ALL FAULTS, AND DISCLAIMS ALL WARRANTIES, EXPRESS OR IMPLIED, INCLUDING, WITHOUT LIMITATION, ANY IMPLIED WARRANTIES OF MERCHANTABILITY, FITNESS FOR A PARTICULAR PURPOSE, OR NON-INFRINGEMENT OF THIRD PARTY INTELLECTUAL PROPERTY RIGHTS.

These resources are intended for developers skilled in the art designing with Renesas products. You are solely responsible for (1) selecting the appropriate products for your application, (2) designing, validating, and testing your application, and (3) ensuring your application meets applicable standards, and any other safety, security, or other requirements. These resources are subject to change without notice. Renesas grants you permission to use these resources only for development of an application that uses Renesas products. Other reproduction or use of these resources is strictly prohibited. No license is granted to any other Renesas intellectual property or to any third party intellectual property. Renesas disclaims responsibility for, and you will fully indemnify Renesas and its representatives against, any claims, damages, costs, losses, or liabilities arising out of your use of these resources. Renesas' products are provided only subject to Renesas' Terms and Conditions of Sale or other applicable terms agreed to in writing. No use of any Renesas resources expands or otherwise alters any applicable warranties or warranty disclaimers for these products.

(Disclaimer Rev.1.0 Mar 2020)

### Corporate Headquarters

TOYOSU FORESIA, 3-2-24 Toyosu,  
Koto-ku, Tokyo 135-0061, Japan  
[www.renesas.com](http://www.renesas.com)

### Contact Information

For further information on a product, technology, the most up-to-date version of a document, or your nearest sales office, please visit:  
[www.renesas.com/contact/](http://www.renesas.com/contact/)

### Trademarks

Renesas and the Renesas logo are trademarks of Renesas Electronics Corporation. All trademarks and registered trademarks are the property of their respective owners.