

DWG. NO.  
SD-35129-001

SIMILAR ITEM

PROJECT NO.

C

B

DO NOT SCALE DRAWING  
DIMENSION IN METRIC

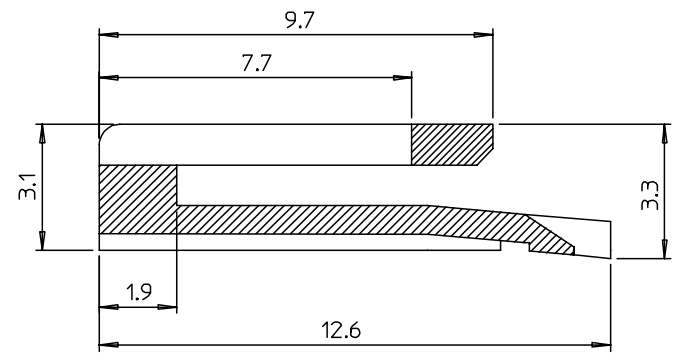
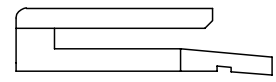
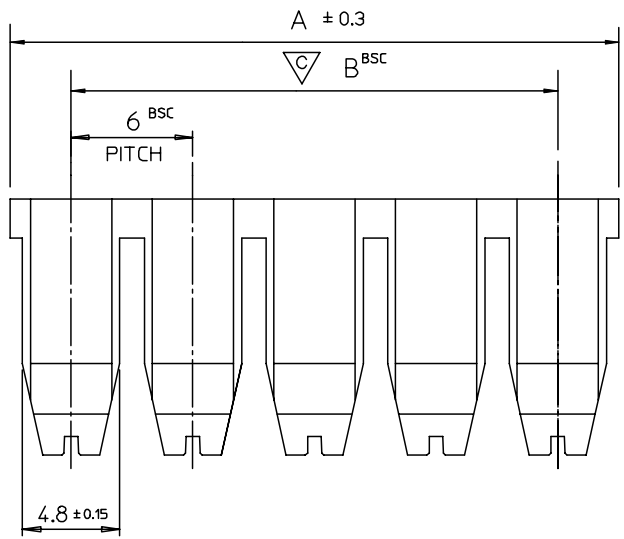
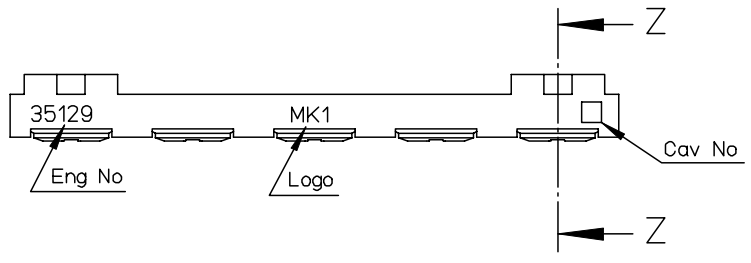
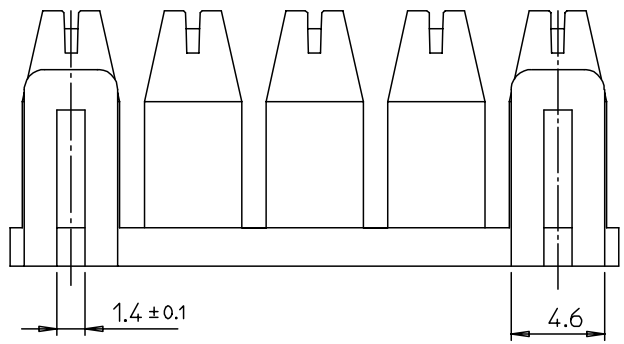

NOTES

1. MATERIALS: POLYESTER(PBT), UL94V-0, COLOR: NATURAL(WHITE)
2. DRAFT TO BE 0°30' UNLESS SPECIFIED.
3. WARPING TO BE 0.20 MAX.
4. PERMISSIBLE FLASH: 0.10MAX.
5. MATED HOUSING : 35127-\*\*\*\*  
35128-\*\*\*\*
6. PRODUCT SPECIFICATION : PS35129

24	30	351290500	35129-0500	5
18	24	351290400	35129-0400	4
12	18	351290300	35129-0300	3
6	12	351290200	35129-0200	2
B	A	MAT'L NO	ENG NO	CIRCUITS

REVISED	DESCRIPTION
ECN NO. KOR2003-0140	
DRWN:H.S.SHIN 02.12.17	
CHK: J.K.OH	
APPR: C.W.LEE	
C	REV

QUALITY SYMBOLS
MAJOR =
CRITICAL = 1

GENERAL TOLERANCES: (UNLESS SPECIFIED)	
mm	INCH
4 PLACES ±0.	±
3 PLACES ±0.	±
2 PLACES ±0.	±
1 PLACE ±0.2	±
ANGULAR: ± 1°	
DRAFT WHERE APPLICABLE MUST REMAIN WITHIN DIMENSIONS	

SCALE 4:1	DESIGN UNITS <input checked="" type="checkbox"/> mm <input type="checkbox"/> INCH
DRAWN BY & DATE Y.J.KIM 92.01.29	
CHECKED BY & DATE Y.J.KIM 92.01.29	
APPROVED BY & DATE C.W.LEE 92.01.29	
CAD FILENAME SD35129A_C.MI	MATERIAL NO. SEE TABLE

DIMENSIONS: <input type="checkbox"/> mm <input type="checkbox"/> INCH <input checked="" type="checkbox"/> mm ONLY		SHT	REV
THIRD ANGLE PROJECTION		REVISE ON CAD ONLY	

TITLE:  
6.0 PITCH W-t-W TPA

**MOLEX INCORPORATED**

DRAWING NO. SD-35129-001	SHEET NO. 1 of 1
-----------------------------	---------------------

THIS DRAWING CONTAINS INFORMATION THAT IS PROPRIETARY TO MOLEX INCORPORATED AND SHOULD NOT BE USED WITHOUT WRITTEN PERMISSION.

F

E

D

C

B

A

8 7 6 5 4 3 2 1

8 7 6 5 4 3 2 1 KOREA MX-A3