

NOTES:

- COLORLESS CLEAR WINDOW.
- LED CHIP: AlInGaP YELLOW, AlInGaP GREEN, InGaN GREEN, InGaN BLUE.
- 2000 PARTS/REEL, 330 mm DIA. (13") REEL WITH 12 mm WIDTH CARRIER. REEL AND PACKAGING HAS A LABEL WITH DIALIGHT LOGO, DIALIGHT P/N, QTY PER REEL, DATE CODE, INTENSITY BIN CODE, COUNTRY OF ORIGIN. 20 PC SAMPLE STRIP PACKAGING SIMILAR LABELING ON BAG ONLY.
- DIALIGHT PART NUMBER: 597-2201-815F FOR YELLOW ON 13" REEL
597-2321-816F FOR GREEN ON 13" REEL
597-2601-817F FOR BLUE ON 13" REEL
597-2201-818F FOR YELLOW ON 20 PC SAMPLE STRIP
597-2321-819F FOR GREEN ON 20 PC SAMPLE STRIP
597-2601-820F FOR BLUE ON 20 PC SAMPLE STRIP
597-2901-821F FOR WHITE ON 20 PCS SAMPLE STRIP
597-2901-822F FOR WHITE ON 13" REEL
597-2301-823F FOR 570nm GREEN LOW VF ON 20 PCS SAMPLE STRIP
597-2301-824F FOR 570nm GREEN LOW VF ON 13" REEL
- TERMINALS ARE TIN (Sn) PLATED WITH NICKEL (Ni) UNDERPLATING OVER COPPER (Cu)
- THIS ASSEMBLY CONTAINS ELECTROSTATIC DISCHARGE SENSITIVE DEVICES (ESDS). MAINTAIN ALL PRECAUTIONARY MEASURES DURING ASSEMBLY, HANDLING AND STORAGE IN ACCORDANCE WITH IPC-A-610.

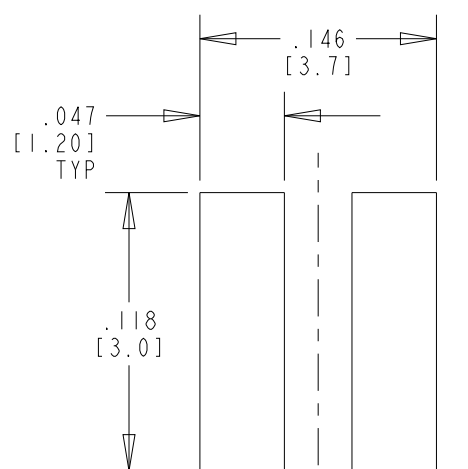

RECOMMENDED PAD LAYOUT

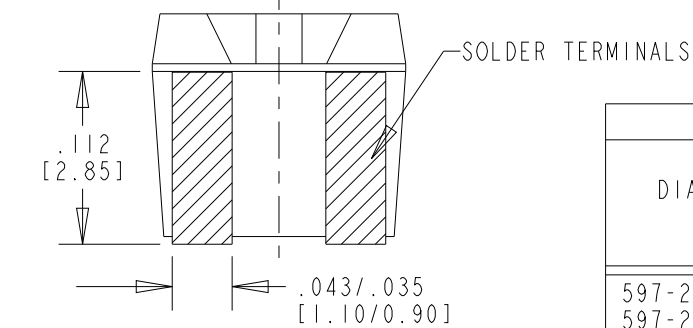
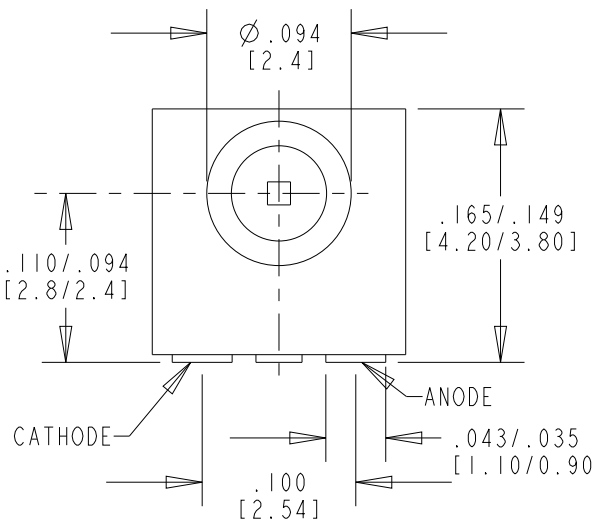
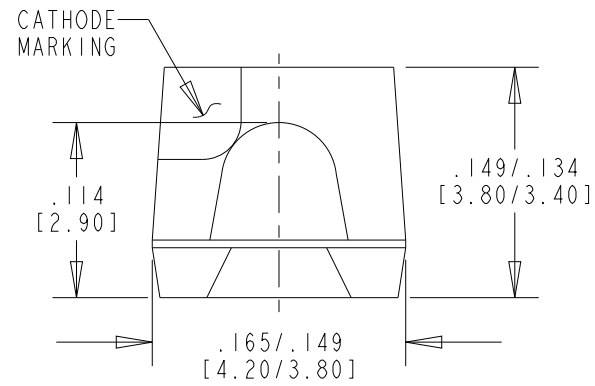
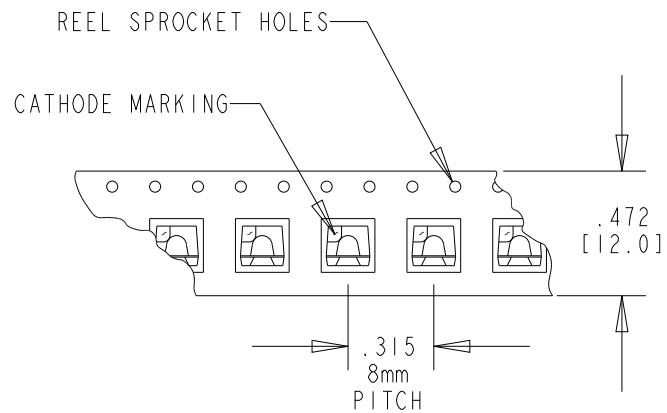
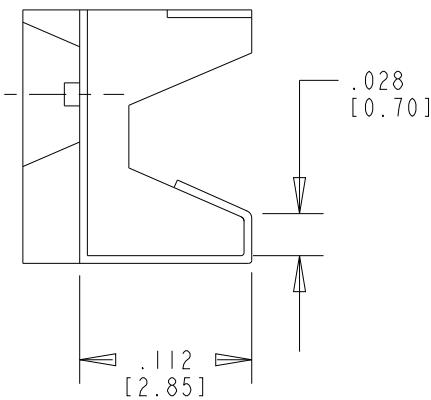

OPERATING CHARACTERISTICS AT T _a = 25°C													
DIALIGHT P/N	COLOR	I _f (mA)	FORWARD VOLTAGE (V)			LUMINOUS INTENSITY (mcd)			PEAK WAVELENGTH (nm)	DOMINANT WAVELENGTH (nm)			VIEWING ANGLE (2θ 1/2)
			MIN.	TYP.	MAX.	MIN.	TYP.	MAX.	TYP.	MIN.	TYP.	MAX.	
597-2201-815F 597-2201-818F	AlInGaP YELLOW	20	1.8	2.1	2.4	280	—	900	594	580	587	595	120
597-2321-816F 597-2321-819F	InGaN GREEN	20	3.0	3.5	4.1	355	—	900	523	519	528	537	120
597-2301-823F 597-2301-824F	AlInGaP GREEN	20	1.8	2.0	2.4	45	—	112	572	566	570	575	120
597-2601-817F 597-2601-820F	InGaN BLUE	20	3.0	3.6	4.1	90	—	224	465	464	470	476	120
597-2901-821F 597-2901-822F	InGaN WHITE	20	3.0	3.6	4.1	355	—	710	—	x=.295 y=.259	x=.330 y=.330	x=.364 y=.380	120

ABSOLUTE MAXIMUM RATINGS AT 25°C AMBIENT	AlInGaP GREEN	InGaN WHITE	AlInGaP YELLOW	InGaN GREEN	InGaN BLUE	UNITS
POWER DISSIPATION	80	85	110	85	85	mW
CONTINUOUS FORWARD CURRENT	30	20	40	20	20	mA
REVERSE VOLTAGE	12	5	12	5	5	V
OPERATING TEMPERATURE	-40 TO +100					°C
STORAGE TEMPERATURE	-40 TO +100					°C

REV	ECN NO	REVISIONS	DRN	CKD	APP	DATE
A	—	NEW RELEASE	TWC	N.O.	MES	4-26-06
B	—	CHART ERROR I _f =20mA WAS 30mA FOR 597-2201-815F, 818F, P/N 597-2201-819F CORRECTED TO 597-2321-819F	SM	N.O.	MES	5-15-07
C	—	ADDED 597-2901-821F, 597-2901-822F, PRELIMINARY 597-2301-823F & 597-2301-824F	SM	N.O.	MES	6-4-07
D	—	".165/.149" IN TOP VIEW RE-DIMENSIONED AS WIDTH OF LED; ADDED AlInGaP GREEN TO NOTE 2; ADDED DICE TO COLORS IN TABLES.	KLJ	NO	—	2-31-08
E	—	UPDATED THE PAD LAYOUT	BP	—	NO	1-4-17

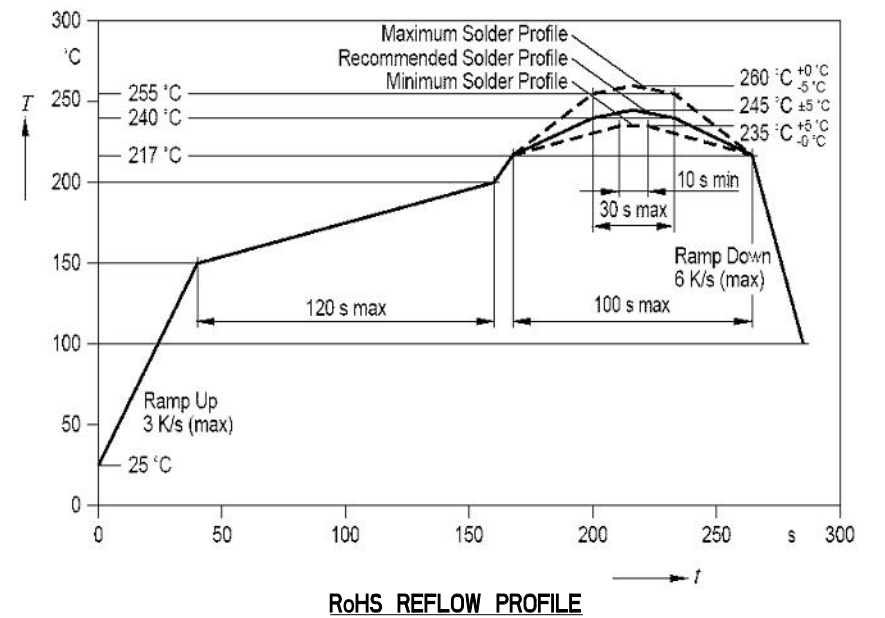

RoHS Compliant 597-2XX1-8XXF Surface Mount LED

Part Numbers with the "F" suffix ending are RoHS Compliant. Example: 597-2201-815F
Packaging is marked with "RoHS Compliant" label or equivalent markings. Parts can be wave soldered, dip soldered or hand soldered using typical lead-free soldering process with max 260°C temp. for 5 sec.



ATTENTION:
OBSERVE PRECAUTIONS FOR
HANDLING ELECTROSTATIC
SENSITIVE DEVICES

THIS DRAWING AND THE CONTENTS HEREIN ARE CONFIDENTIAL AND THE SOLE PROPERTY OF DIALIGHT CORP. REPRODUCTION OF THIS DRAWING OR CONSTRUCTION OF ANY PARTS WITHIN THIS DRAWING ARE FORBIDDEN WITHOUT THE WRITTEN CONSENT OF DIALIGHT CORP.		
SCALE: DRAWING SCALE	DRAWING NUMBER	REV
ALL DIM'S: INCH (mm)	C-17330	E
TOLERANCES: UNLESS OTHERWISE SPECIFIED	TITLE SMT-SIDELED 1616 PKG RoHS COMPLIANT	
FRACTIONS: ±1/64	MATERIAL	
DECIMALS (.XX): ±.01	FINISH	
DECIMALS (.XXX): ±.005	FSCM 83330	
DECIMALS (.XXXX): ±.0005	SHEET 1 OF 1 FAMILY TABLE:	
ANGLES: ±1°	Dialight 1501 ROUTE 34 SOUTH FARMINGDALE, NJ 07727 (732) 919-3119 www.dialight.com	