

SPEC for Mass Production

Spec No.	TQ3C-8EAF0-E1YBJ11-00
Date	November 20, 2019

TYPE: TN0104ANVAANN-GN00

< 1.04 inch Reflective (slightly transmissive) Dot Matrix
Memory LC Display >

CONTENTS

1. Application
2. Construction and Outline
3. Mechanical Specifications
4. Absolute Maximum Ratings
5. Electrical Characteristics
6. Interface Signals
7. Input Timing Characteristics
8. Optical Characteristics
9. Warranty
10. Precautions for Use
11. Reliability test data
12. Outline drawing



KYOCERA CORPORATION

Original Issue Date	Designed by: Engineering dept.			Confirmed by: QA dept.	
	Prepared	Checked	Approved	Checked	Approved
November 20, 2019	T. Onodera	Y. Asada	A. Imacoki	S. Kishimoto	O. Sato

Spec No. TQ3C-8EAF0-E1YBJ11-00	Part No. TN0104ANVAANN-GN00	Page -
-----------------------------------	--------------------------------	-----------

Warning

1. This Kyocera LCD module has been specifically designed for use only in electronic devices and industrial machines in the area of audio control, office automation, industrial control, home appliances, etc. The module should not be used in applications where the highest level of safety and reliability are required and module failure or malfunction of such module results in physical harm or loss of life, as well as enormous damage or loss.
Such fields of applications include, without limitation, medical, aerospace, communications infrastructure, atomic energy control. Kyocera expressly disclaims any and all liability resulting in any way to the use of the module in such applications.
2. Customer agrees to indemnify, defend and hold Kyocera harmless from and against any and all actions, claims, damages, liabilities, awards, costs, and expenses, including legal expenses, resulting from or arising out of Customer's use, or sale for use, or Kyocera modules in applications.

Caution

1. Kyocera shall have the right, which Customer hereby acknowledges, to immediately scrap or destroy tooling for Kyocera modules for which no Purchase Orders have been received from the Customer in a two-year period.

Spec No. TQ3C-8EAF0-E1YBJ11-00	Part No. TN0104ANVAANN-GN00	Page -
-----------------------------------	--------------------------------	-----------

Revision record

Date		Designed by : Engineering dept.			Confirmed by : QA dept.	
		Prepared	Checked	Approved	Checked	Approved
Rev.No.	Date	Page	Descriptions			

仕様書 No. TQ3C-8EAF0-E1YBJ11-00	品名 TN0104ANVAANN-GN00	ページ 1
----------------------------------	--------------------------	----------

1. Application

This document defines the specification of TN0104ANVAANN-GN00. (RoHS Compliant)

2. Construction and Outline

LCD : Reflective (slightly transmissive) dot matrix Monochrome TFT
 Backlight System : None
 Polarizer : Glare type
 Additional circuit : 1-bit pixel memory function in LCD

3. Mechanical Specifications

Item	Specification	Unit
Outline dimensions 1)	29.5(W) × 31.0(H)	mm
Active area	26.5(W) × 26.5(H) (Octagon 1.04 inch)	mm
Dot format	176(W) × 176(H)	Dot
Dot pitch	0.1505(W) × 0.1505(H)	mm
Color	Black-and-White (Binary)	-
LC Mode	ECB mode (Normally black)	-
Mass	2.5	g

1) FPC is not included. Please refer to the drawing for details.

4. Absolute Maximum Ratings

4-1. Electrical absolute maximum ratings

Item	Symbol	Min.	Max.	Unit
Supply voltage	V _{DD}	-0.3	4.0	V
LCD common voltage	V _{COM}	-0.3	4.0	V
Input signal voltage 1)	-	-0.3	4.0	V

1) Input signals : SCLK, SI[7:0], DEN, ENBG, ENBS, XRST

4-2. Environmental absolute maximum ratings

Item	Symbol	Min.	Max.	Unit
Operating temperature 1)	T _{OP}	-20	80	°C
Storage temperature 2)	T _{STO}	-30	85	°C
Operating humidity 3)	H _{OP}	-	4)	%RH
Storage humidity 3)	H _{STO}	-	4)	%RH

- 1) Operating temperature means a temperature which operation shall be guaranteed. Since display performance is evaluated at 25°C, another temperature range should be confirmed.
- 2) Store LCD at normal temperature/humidity. Keep them free from vibration and shock. An LCD that is kept at a low or a high temperature for a long time can be defective due to other conditions, even if the low or high temperature satisfies the standard. (Please refer to "Precautions for Use" for details.)
- 3) Non-condensing
- 4) Temp. $\leq 40^{\circ}\text{C}$, 95%RH Max.
Temp. $> 40^{\circ}\text{C}$, Absolute humidity shall be less than 95%RH at 40°C

5. Electrical Characteristics

5-1. LCD driving characteristics

Temp. = 25°C

Item	Symbol	Condition	Min.	Typ.	Max.	Unit
Supply voltage	V _{DD}	—	2.7	3.0	3.3	V
LCD common voltage	V _{COM}	“Low” level	GND	—	GND+0.1	V
		“High” level	V _{DD} -0.1	—	V _{DD}	V
Input signal voltage 1)	V _{IL}	“Low” level	GND	—	GND+0.1	V
	V _{IH}	“High” level	V _{DD} -0.1	—	V _{DD}	V
Input leak current 1)	I _{IN}	T _{OP} =25°C	—	4	15	nA
Current consumption 4)	I _{DD_opr}	2)	—	3.5	8.0	μA
	I _{DD_stb}	3)	—	0.5	1.5	μA
Input capacitance 1)	C _{IN1}	—	—	3	10	pF
LCD common voltage terminal capacitance	C _{VCOM}	—	—	60	90	nF

1) SCLK, SI[7:0], DEN, ENBG, ENBS, XRST

2) 1 Hz full display rewriting

Using address auto increment mode for horizontal direction

3) Keeping static image, and polarity inversion of V_{COM} with a period of 1 sec.

SCLK, SI [7:0], DEN, ENBG, ENBS: “L” state.

XRST: “H” state.

4) Current consumption : V_{DD} and V_{COM}

* Value of the current consumption is without smoothing capacitor.

5-2. Power ON-OFF sequence

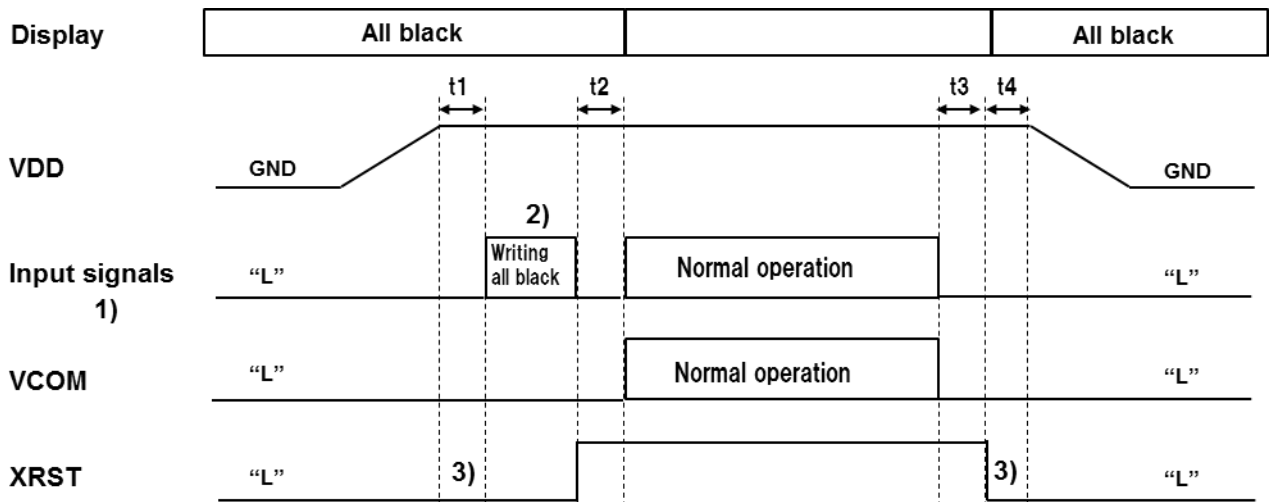

Item	Symbol	Min.	Typ.	Max.	Unit
Power ON-OFF sequence	t1	0	—	—	μsec
	t2	1	—	—	msec
	t3	1	—	—	msec
	t4	1	—	—	msec

- 1) SCLK, SI[7:0], DEN, ENBG, ENBS
- 2) Rewriting to black for all addresses.
- 3) Display OFF when XRST = "L".
VCOM = "L" is necessary when XRST = "L".
Black display when display is OFF.

Data in pixel memory is random with black or white at power ON.

Possible to prevent black-white random data display by black display when XRST = "L".

5-3. Address Mapping

5-3-1. Physical location

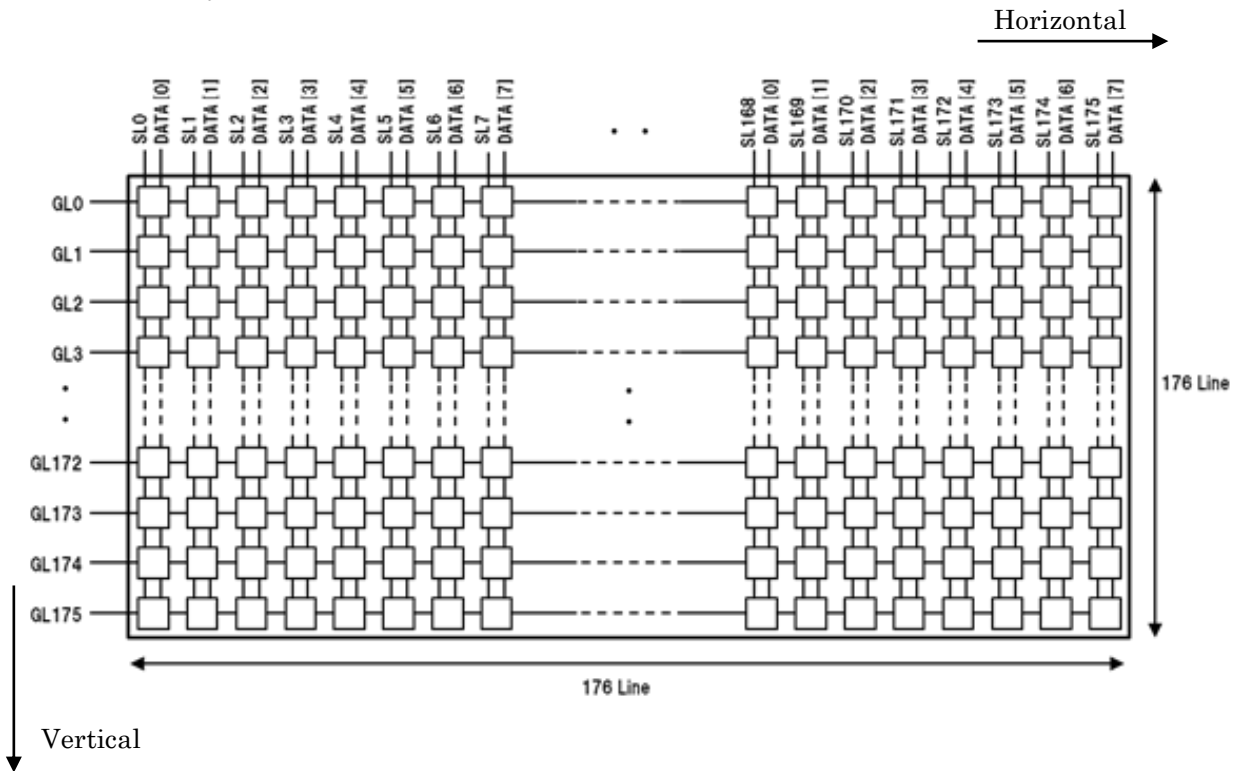

5-3-2. Valid pixel

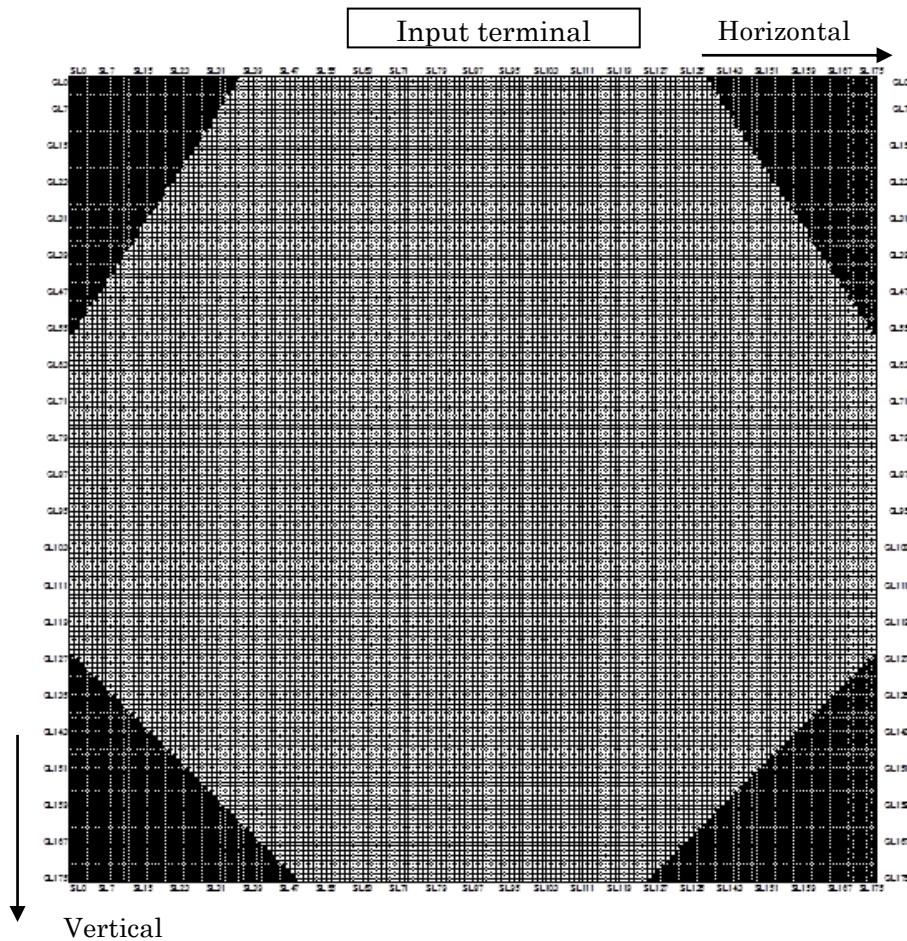

5-3-3. Valid pixel (V,H)

GL	Valid pixel range		GL	Valid pixel range		GL	Valid pixel range	
	SL left side	SL right side		SL left side	SL right side		SL left side	SL right side
GL0	SL37	SL138	GL64	SL0	SL175	GL128	SL3	SL172
GL1	SL36	SL139	GL65	SL0	SL175	GL129	SL4	SL171
GL2	SL36	SL139	GL66	SL0	SL175	GL130	SL5	SL170
GL3	SL35	SL140	GL67	SL0	SL175	GL131	SL6	SL169
GL4	SL34	SL141	GL68	SL0	SL175	GL132	SL7	SL168
GL5	SL34	SL141	GL69	SL0	SL175	GL133	SL8	SL167
GL6	SL33	SL142	GL70	SL0	SL175	GL134	SL9	SL166
GL7	SL32	SL143	GL71	SL0	SL175	GL135	SL10	SL165
GL8	SL32	SL143	GL72	SL0	SL175	GL136	SL11	SL164
GL9	SL31	SL144	GL73	SL0	SL175	GL137	SL12	SL163
GL10	SL31	SL144	GL74	SL0	SL175	GL138	SL13	SL162
GL11	SL30	SL145	GL75	SL0	SL175	GL139	SL14	SL161
GL12	SL29	SL146	GL76	SL0	SL175	GL140	SL15	SL160
GL13	SL29	SL146	GL77	SL0	SL175	GL141	SL16	SL159
GL14	SL28	SL147	GL78	SL0	SL175	GL142	SL17	SL158
GL15	SL27	SL148	GL79	SL0	SL175	GL143	SL18	SL157
GL16	SL27	SL148	GL80	SL0	SL175	GL144	SL19	SL156
GL17	SL26	SL149	GL81	SL0	SL175	GL145	SL20	SL155
GL18	SL25	SL150	GL82	SL0	SL175	GL146	SL21	SL154
GL19	SL25	SL150	GL83	SL0	SL175	GL147	SL22	SL153
GL20	SL24	SL151	GL84	SL0	SL175	GL148	SL23	SL152
GL21	SL23	SL152	GL85	SL0	SL175	GL149	SL24	SL151
GL22	SL23	SL152	GL86	SL0	SL175	GL150	SL25	SL150
GL23	SL22	SL153	GL87	SL0	SL175	GL151	SL26	SL149
GL24	SL21	SL154	GL88	SL0	SL175	GL152	SL27	SL148
GL25	SL21	SL154	GL89	SL0	SL175	GL153	SL28	SL147
GL26	SL20	SL155	GL90	SL0	SL175	GL154	SL29	SL146
GL27	SL19	SL156	GL91	SL0	SL175	GL155	SL30	SL145
GL28	SL19	SL156	GL92	SL0	SL175	GL156	SL31	SL144
GL29	SL18	SL157	GL93	SL0	SL175	GL157	SL32	SL143
GL30	SL17	SL158	GL94	SL0	SL175	GL158	SL33	SL142
GL31	SL17	SL158	GL95	SL0	SL175	GL159	SL34	SL141
GL32	SL16	SL159	GL96	SL0	SL175	GL160	SL35	SL140
GL33	SL15	SL160	GL97	SL0	SL175	GL161	SL36	SL139
GL34	SL15	SL160	GL98	SL0	SL175	GL162	SL37	SL138
GL35	SL14	SL161	GL99	SL0	SL175	GL163	SL38	SL137
GL36	SL14	SL161	GL100	SL0	SL175	GL164	SL39	SL136
GL37	SL13	SL162	GL101	SL0	SL175	GL165	SL40	SL135
GL38	SL12	SL163	GL102	SL0	SL175	GL166	SL41	SL134
GL39	SL12	SL163	GL103	SL0	SL175	GL167	SL42	SL133
GL40	SL11	SL164	GL104	SL0	SL175	GL168	SL43	SL132
GL41	SL10	SL165	GL105	SL0	SL175	GL169	SL44	SL131
GL42	SL10	SL165	GL106	SL0	SL175	GL170	SL45	SL130
GL43	SL9	SL166	GL107	SL0	SL175	GL171	SL46	SL129
GL44	SL8	SL167	GL108	SL0	SL175	GL172	SL47	SL128
GL45	SL8	SL167	GL109	SL0	SL175	GL173	SL48	SL127
GL46	SL7	SL168	GL110	SL0	SL175	GL174	SL49	SL126
GL47	SL6	SL169	GL111	SL0	SL175	GL175	SL50	SL125
GL48	SL6	SL169	GL112	SL0	SL175			
GL49	SL5	SL170	GL113	SL0	SL175			
GL50	SL4	SL171	GL114	SL0	SL175			
GL51	SL4	SL171	GL115	SL0	SL175			
GL52	SL3	SL172	GL116	SL0	SL175			
GL53	SL2	SL173	GL117	SL0	SL175			
GL54	SL2	SL173	GL118	SL0	SL175			
GL55	SL1	SL174	GL119	SL0	SL175			
GL56	SL0	SL175	GL120	SL0	SL175			
GL57	SL0	SL175	GL121	SL0	SL175			
GL58	SL0	SL175	GL122	SL0	SL175			
GL59	SL0	SL175	GL123	SL0	SL175			
GL60	SL0	SL175	GL124	SL0	SL175			
GL61	SL0	SL175	GL125	SL0	SL175			
GL62	SL0	SL175	GL126	SL1	SL174			
GL63	SL0	SL175	GL127	SL2	SL173			

5-4. Address select table

5-4-1. Vertical address select table

GS[7]	GS[6]	GS[5]	GS[4]	GS[3]	GS[2]	GS[1]	GS[0]	Select GL
0	0	0	0	0	0	0	0	GL0
0	0	0	0	0	0	0	1	GL1
0	0	0	0	0	0	1	0	GL2
0	0	0	0	0	0	1	1	GL3
⋮	⋮	⋮	⋮	⋮	⋮	⋮	⋮	⋮
⋮	⋮	⋮	⋮	⋮	⋮	⋮	⋮	⋮
1	0	1	0	1	1	0	0	GL172
1	0	1	0	1	1	0	1	GL173
1	0	1	0	1	1	1	0	GL174
1	0	1	0	1	1	1	1	GL175
1	0	1		0	0	0	0	Invalid 1)
⋮	⋮	⋮	⋮	⋮	⋮	⋮	⋮	
⋮	⋮	⋮	⋮	⋮	⋮	⋮	⋮	
1	1	1	1	1	1	1	1	

1) When invalid address is set, display does not change.

5-4-2. Horizontal address select table

SS[7]	SS[6]	SS[5]	SS[4]	SS[3]	Select SL	Direction of auto address increment
0	0	0	0	0	SL0~7	
0	0	0	0	1	SL8~15	
0	0	0	1	0	SL16~23	
0	0	0	1	1	SL24~31	
⋮	⋮	⋮	⋮	⋮	⋮	
⋮	⋮	⋮	⋮	⋮	⋮	
1	0	0	1	0	SL144~151	
1	0	0	1	1	SL152~159	
1	0	1	0	0	SL160~167	
1	0	1	0	1	SL168~175	
1	0	1	1	0	Invalid 1)	
⋮	⋮	⋮	⋮	⋮		
⋮	⋮	⋮	⋮	⋮		
1	1	1	1	1		

1) When invalid address is set, display does not change.

In case of using address auto increment mode, the internal address returns to SL0-7 in the next cycle and then starts auto increment.

5-4-3. Data select table

Select SL					DATA signal
SL0	SL8	・ ・	SL160	SL168	DATA[0]
SL1	SL9	・ ・	SL161	SL169	DATA[1]
SL2	SL10	・ ・	SL162	SL170	DATA[2]
SL3	SL11	・ ・	SL163	SL171	DATA[3]
SL4	SL12	・ ・	SL164	SL172	DATA[4]
SL5	SL13	・ ・	SL165	SL173	DATA[5]
SL6	SL14	・ ・	SL166	SL174	DATA[6]
SL7	SL15	・ ・	SL167	SL175	DATA[7]

5-4-4. Table of Serial input signal and Address / Data

I/F信号	Address / Data			
	1 st cycle	2 nd cycle	3 rd cycle	After 4 th cycle 1)
SI[0]	GS[0]	don't care	DATA[0]	DATA[0]
SI[1]	GS[1]	don't care	DATA[1]	DATA[1]
SI[2]	GS[2]	don't care	DATA[2]	DATA[2]
SI[3]	GS[3]	SS[3]	DATA[3]	DATA[3]
SI[4]	GS[4]	SS[4]	DATA[4]	DATA[4]
SI[5]	GS[5]	SS[5]	DATA[5]	DATA[5]
SI[6]	GS[6]	SS[6]	DATA[6]	DATA[6]
SI[7]	GS[7]	SS[7]	DATA[7]	DATA[7]

1) In case of using address auto increment mode

5-4-5. Data signal and Display

DATA Signal	Display
0	White
1	Black

6. Interface Signals

No.	Symbol	Description	I/O 1)	Voltage	Unit	Note
1	VCOM	LCD common voltage	P	0.0/3.0	V	
2	VDD	Supply voltage (3.0V)	P	3.0	V	
3	VSS	GND	P	0.0	V	
4	ENBS	Write enable signal (Horizontal)	I	0.0/3.0	V	3)
5	XRST	Reset signal	I	0.0/3.0	V	2) 3)
6	SI[7]	Serial input signal	I	0.0/3.0	V	
7	SI[6]	Serial input signal	I	0.0/3.0	V	
8	SI[5]	Serial input signal	I	0.0/3.0	V	
9	SI[4]	Serial input signal	I	0.0/3.0	V	
10	SI[3]	Serial input signal	I	0.0/3.0	V	
11	SI[2]	Serial input signal	I	0.0/3.0	V	
12	SI[1]	Serial input signal	I	0.0/3.0	V	
13	SI[0]	Serial input signal	I	0.0/3.0	V	
14	DEN	Serial input control signal	I	0.0/3.0	V	
15	SCLK	Serial clock signal	I	0.0/3.0	V	3)
16	ENBG	Write enable signal (Vertical)	I	0.0/3.0	V	3)
17	VSS	GND	P	0.0	V	
18	VDD	Supply voltage (3.0V)	P	3.0	V	
19	VCOM	LCD common voltage	P	0.0/3.0	V	

- 1) P: Power supply
I: Input

- 2) XRST = "H": Display ON
XRST = "L": Display OFF (Display become "All black", pixel memory is maintained)
VCOM = "L" is necessary when XRST = "L"

- 3) Need to guard from signal noise
If there is an abnormal signal not described in the timing chart on these signals, display may be distorted. Please carefully guard these signals since even if signal noise with small pulse width may cause malfunction.

7. Input Timing Characteristics

7-1. Writing operation specifications (Display update mode)

- Any point of pixels can be written randomly .
- The unit of writing pixel is 8 dot.
- Address/Data is transferred sequentially by SI[7:0] signal synchronized with SCLK.
1st cycle : Vertical Address, 2nd cycle : Horizontal Address, 3rd cycle : Writing Data
- SI[7:0] signal input is recognized as Address or Data by serial input control signal(DEN) .
DEN="L" : SI[7:0] is Address input, DEN="H" : SI[7:0] is Data input
- After Address/Data is transferred, Data is written to pixel memory with activating ENBG and ENBS.
- Address auto increment mode is implemented.
- After horizontal start address is transferred, internal horizontal address is incremented automatically synchronized with SCLK by keeping DEN="H".
- In case of writing data to pixels in horizontal consecutive address, the period of writing pixels becomes shorter because address input is not needed after 2nd address of writing pixels.
- When internal horizontal address reaches to the end of address by auto increment, it returns to 0 next. Vertical address is not incremented.

7-2. Input timing characteristics

	Item	Symbol	Min.	Typ.	Max.	Unit	Note
Input sinal 1)	Signal rise time	trSIG	—	—	50	ns	2)
	Signal fall time	tfSIG	—	—	50	ns	2)
SCLK	SCLK high width	twSCLKH	0.9	—	—	μs	4)
	SCLK low width	twSCLKL	0.9	—	—	μs	4)
SI[7:0]	SI set-up time	tsSI	0.9	—	—	μs	4)
	SI hold time	thSI	0.9	—	—	μs	4)
DEN	DEN set-up time	tsDEN	0.9	—	—	μs	4)
	DEN hold time	thDEN	0.9	—	—	μs	4)
ENBG ENBS	ENBG,S high width	twENBH	4.5	—	—	μs	4)
	SCLK rise→ENBG,S rise	toENB	1.8	—	—	μs	4)
	ENBG,S fall→SCLK rise	tbENB	1.8	—	—	μs	4)
VCOM	VCOM duty	—	—	50	—	%	—
	VCOM rise time	trVCOM	—	100	200	μs	3) 6)
	VCOM fall time	tfVCOM	—	100	200	μs	3) 6)
	VCOM cycle time	tcVCOM	—	1000	—	ms	5)
	VCOM rise/fall → ENBG,S rise	tsVCOM	4	—	—	ms	5)
	ENBG,S fall → VCOM rise/fall	thVCOM	1	—	—	ms	5)

1) SCLK, SI [7:0], DEN, ENBG, ENBS, XRST

2) Signal transition time of 10%↔90% level

3) Signal transition time of 1%↔99% level, All pixel Black

4) Timing is defined at 50% level

5) Timing is defined at 1%/99% level with VCOM, 50% with other signals

6) For the stable operation, resistor insertion to VCOM input outside of LCD panel is needed.
The resistance is estimated 500Ω, but is not the fixed value.

Timing spec of VCOM rise/fall time is the value including the VCOM resistor 500Ω.

7-3. Timing chart

7-3-1. Writing operation (random access)

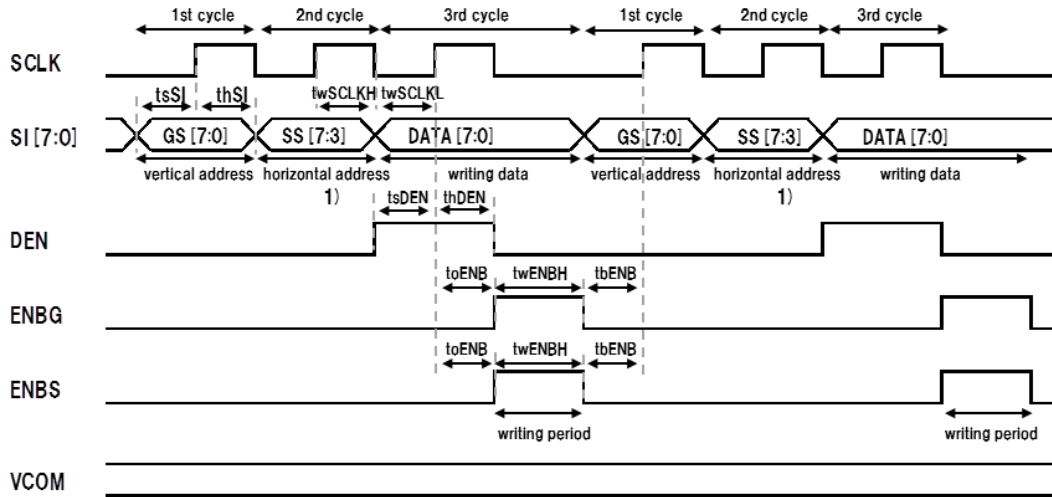

1) SI[2:0] is invalid because horizontal address bit width is 5 bits.

7-3-2. Writing operation (consecutive access: horizontal address auto increment mode)

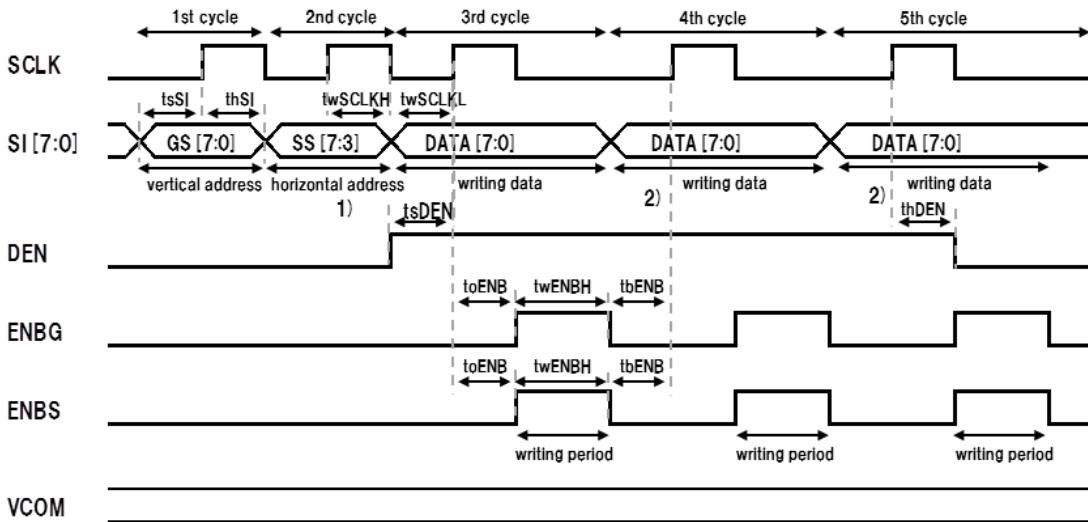

1) SI[2:0] is invalid because horizontal address bit width is 5 bits.

2) After horizontal start address is transferred, internal horizontal address is incremented automatically during DEN="H".

7-3-3. VCOM AC drive

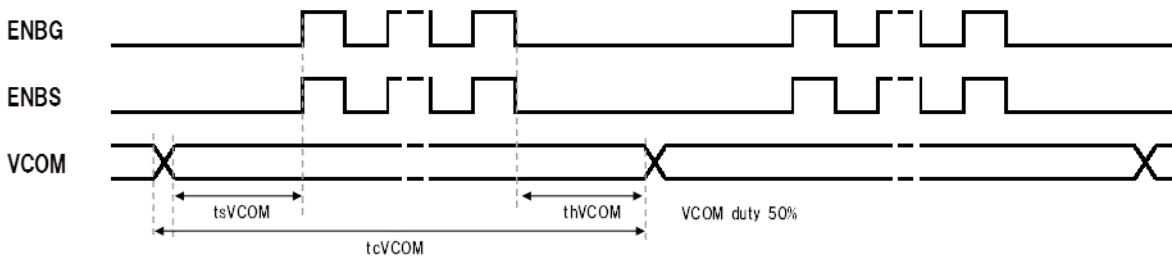

8. Optical Characteristics

VDD=3.0V, VCOM=1Hz, Temp. = 25°C

Item	Symbol	Temp.	Unit	Min.	Typ.	Max.	
Contrast ratio 1)	CR	25°C	-	-	37	-	
Reflectance	-	25°C	%	-	16	-	
Response time 2) 3)	Rise	τ_r	msec	-20°C	-	14	-
				25°C	-	3	-
				40°C	-	3	-
	Fall	τ_f	msec	-20°C	-	33	-
				25°C	-	7	-
				40°C	-	6	-
Viewing angle CR ≥ 2 4) 5)	θ_{upper}	25°C	deg.	-	60	-	
	θ_{lower}			-	60	-	
	θ_{left}			-	60	-	
	θ_{right}			-	60	-	
Chromaticity coordinates	W _x	25°C	-	-	0.305	-	
	W _y			-	0.335	-	

1) Definition of contrast ratio

$$CR(\text{Contrast ratio}) = \frac{\text{Brightness with all pixels "White"}}{\text{Brightness with all pixels "Black"}}$$

2) Definition of response time

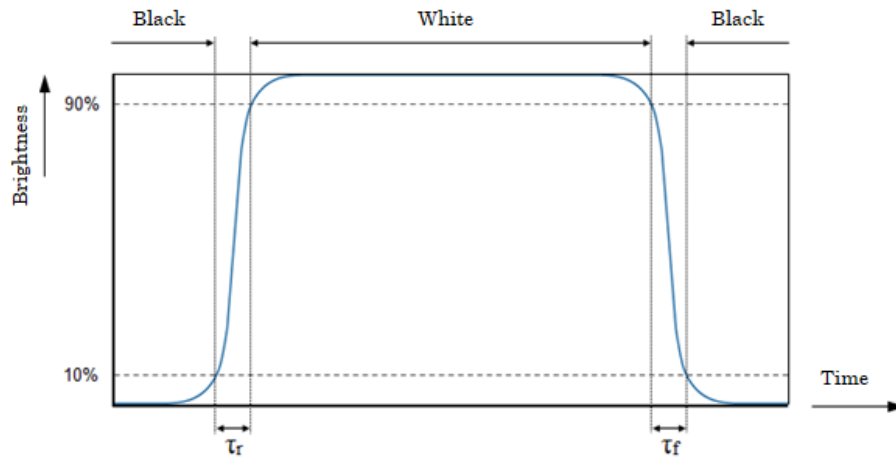
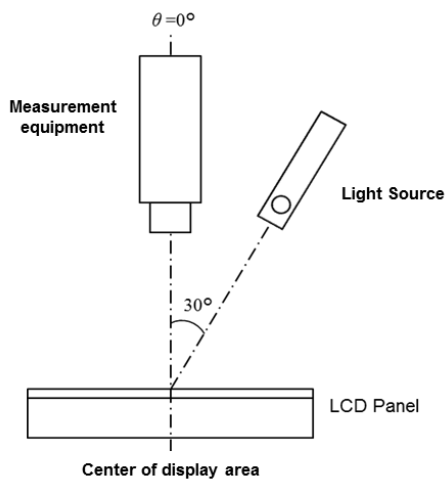
3) About the measurement of Response time
Measurement Equipment (LCD-5200)

4) Definition of viewing angle

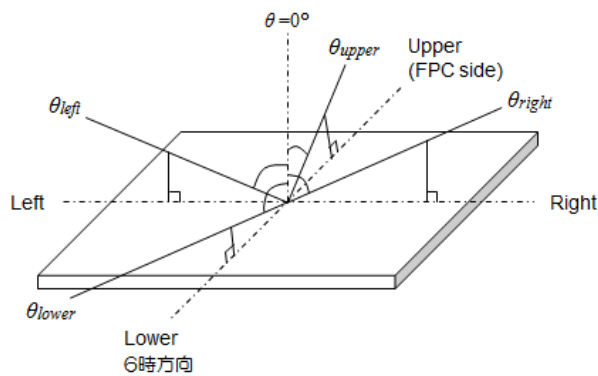

5) About the measurement of viewing angle

Measurement Equipment (LCD-5200)

The viewing angle is measured by changing the angle of the light source.

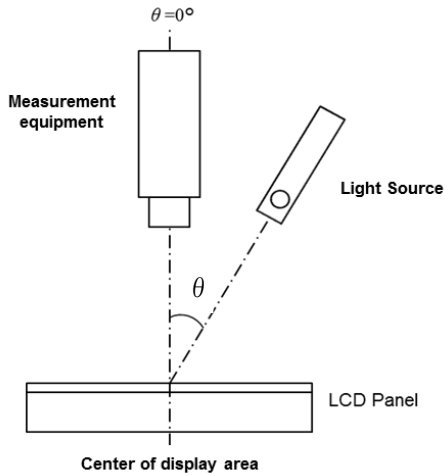

9. Warranty

9-1. Incoming inspection

Please inspect the LCD within one month after your receipt.

9-2. Production warranty

Kyocera warrants its LCD's for a period of 12 months from the ship date. Kyocera shall, by mutual agreement, replace or re-work defective LCD's that are shown to be Kyocera's responsibility.

仕様書 No. TQ3C-8EAF0-E1YBJ11-00	品名 TN0104ANVAANN-GN00	ページ 16
----------------------------------	--------------------------	-----------

10. Precautions for Use

10-1. Installation of the LCD

- 1) A transparent protection plate shall be added to protect the LCD and its polarizer.
- 2) The LCD shall be installed flat, without twisting or bending.
- 3) A transparent protection sheet is attached to the polarizer. Please remove the protection film slowly before use, paying attention to static electricity.
- 4) FPC shall be installed after fixing the glass.
- 5) Do not apply a load to the FPC.
- 6) Do not use an assembly structure where the FPC is pulled or partially stressed.

10-2. Static electricity

- 1) Protect the LCD from static electricity.
- 2) Workers should use body grounding. Operator should wear ground straps.

10-3. LCD operation

- 1) The LCD shall be operated within the limits specified. Operation at values outside of these limits may shorten life, and/or harm display images.

10-4. Storage

- 1) The LCD shall be stored within the temperature and humidity limits specified.
Store in a dark area, and protect the LCD from direct sunlight or fluorescent light.
- 2) Always store the LCD so that it is free from external pressure onto it.

10-5. Usage

- 1) **DO NOT** store in a high humidity environment for extended periods. Polarizer degradation bubbles, and/or peeling off of the polarizer may result.
- 2) The front polarizer is easily scratched or damaged. Prevent touching it with any hard material, and from being pushed or rubbed.
- 3) The LCD screen may be cleaned by wiping the screen surface with a soft cloth or cotton pad using a little Ethanol
- 4) Water may cause damage or discoloration of the polarizer. Clean condensation or moisture from any source immediately.
- 5) Always keep the LCD free from condensation during testing. Condensation may permanently spot or stain the polarizer.
- 6) Do not disassemble LCD because it will result in damage.
- 7) This Kyocera LCD has been specifically designed for use in general electronic devices, but not for use in a special environment such as usage in an active gas. Hence, when the LCD is supposed to be used in a special environment, evaluate the LCD thoroughly beforehand and do not expose the LCD to chemicals such as an active gas.
- 8) Do not use solid-base image pattern for long hours because a temporary afterimage may appear. We recommend using screen saver etc. in cases where a solid-base image pattern must be used.
- 9) Liquid crystal may leak when the LCD is broken. Be careful not to let the fluid go into your eyes and mouth. In the case the fluid touches your body; rinse it off right away with water and soap.
- 10) Do not hold the FPC alone while working.
- 11) Do not scratch or damage the exposed conductor of the FPC or FPC.
- 12) Do not touch the exposed conductor of the FPC.
- 13) Do not bend the FPC toward the surface of LCD near the glass.
- 14) Do not bend the FPC so that stress is concentrated on the FPC.

11. Reliability Test Data

Test item	Test condition	Test time	Judgement
High temp. atmosphere	70°C	240h	Function/Display : No defect Current consumption : No defect
Low temp. atmosphere	-30°C	240h	Function/Display : No defect Current consumption : No defect
High temp. humidity atmosphere	40°C 95%RH	240h	Function/Display : No defect Current consumption : No defect
Temp. cycle	-30°C 0.5h R.T. 0.5h 80°C 0.5h	10cycles	Function/Display : No defect Current consumption : No defect
High temp. operation	60°C	240h	Function/Display : No defect Current consumption : No defect
Low temp. operation	-20°C	240h	Function/Display : No defect Current consumption : No defect

- 1) Each test item uses a test LCD only once. The tested LCD is not used in any other tests.
- 2) The LCD is tested in circumstances in which there is no condensation.
- 3) The reliability test is not an out-going inspection.
- 4) The result of the reliability test is for your reference purpose only.
The reliability test is conducted only to examine the LCD's capability.

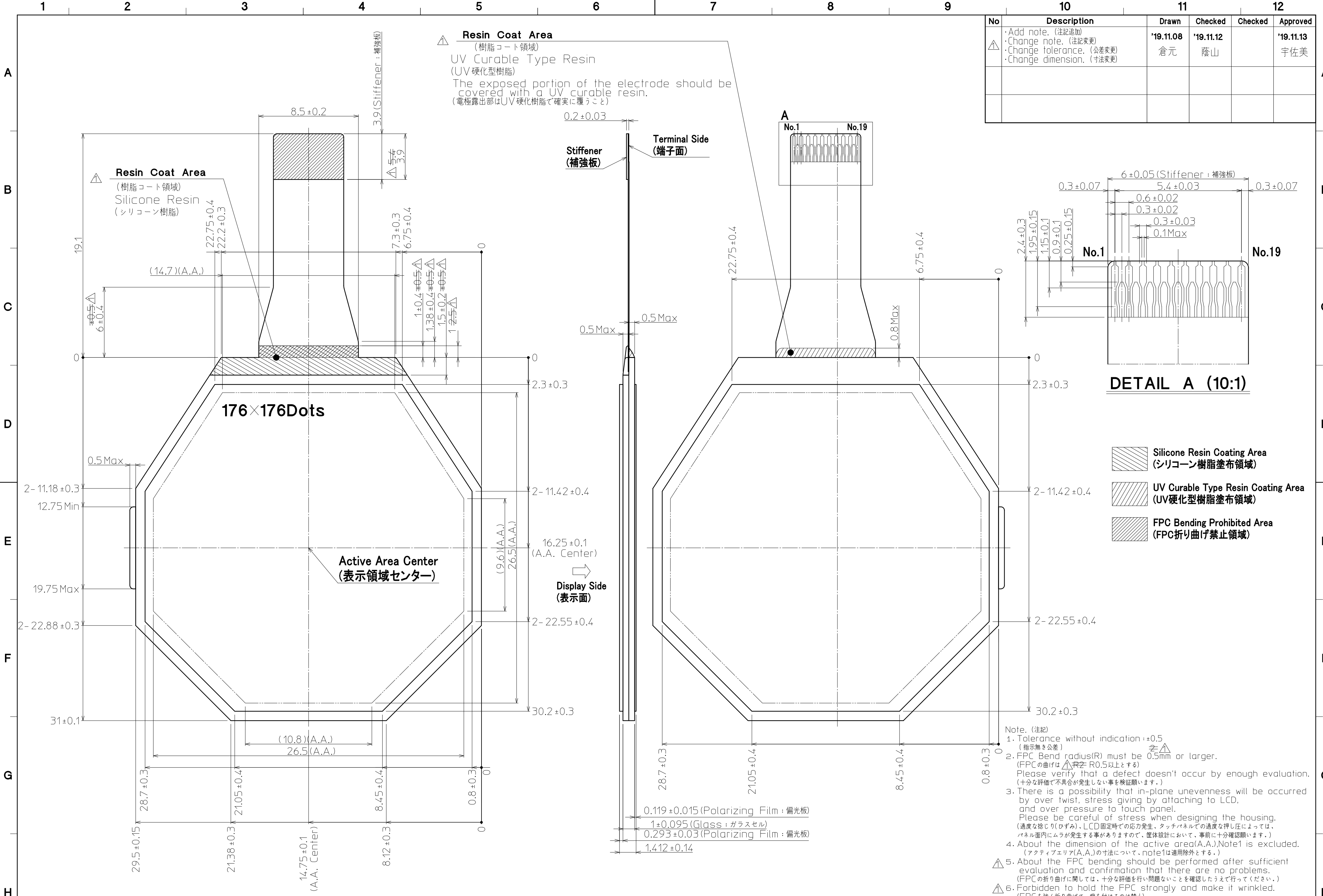

No	Description	Drawn	Checked	Checked	Approved
△	・Add note. (注記追加) ・Change note. (注記変更) ・Change tolerance. (公差変更) ・Change dimension. (寸法変更)	'19.11.08 倉元	'19.11.12 蔭山		'19.11.13 宇佐美

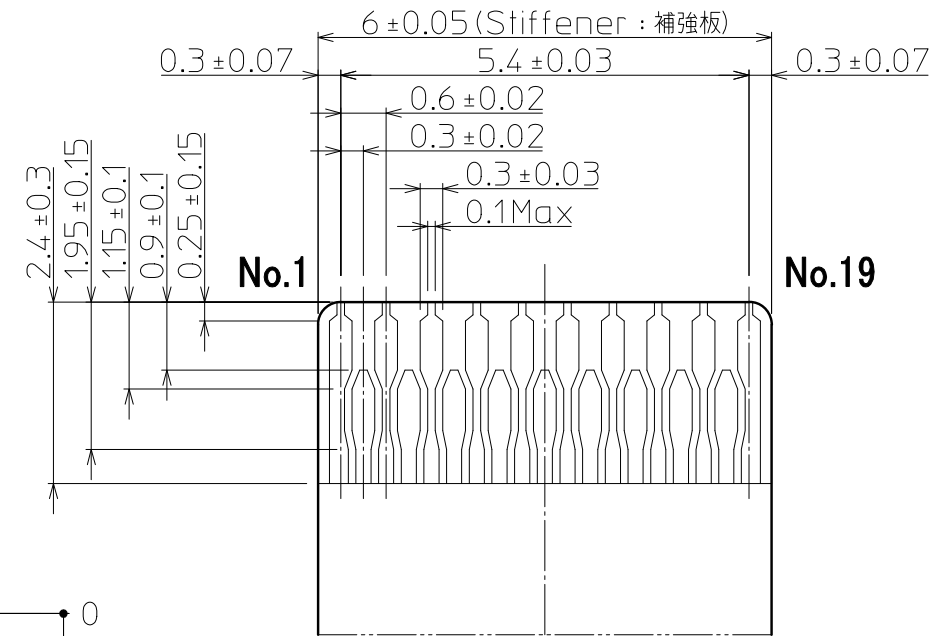

- Silicone Resin Coating Area (シリコン樹脂塗布領域)
- UV Curable Type Resin Coating Area (UV硬化型樹脂塗布領域)
- FPC Bending Prohibited Area (FPC折り曲げ禁止領域)

- Note. (注記)
- Tolerance without indication: ±0.5 (指示無公差)
 - FPC Bend radius(R) must be 0.5mm or larger. (FPCの曲げは R≧R0.5以上とする) Please verify that a defect doesn't occur by enough evaluation. (十分な評価で不具合が発生しない事を検証願います。)
 - There is a possibility that in-plane unevenness will be occurred by over twist, stress giving by attaching to LCD, and over pressure to touch panel. Please be careful of stress when designing the housing. (過度な捻じり(ひずみ)、LCD固定時の応力発生、タッチパネルでの過度な押し圧によっては、パネル面にムラが発生する事がありますので、筐体設計において、事前に十分確認願います。)
 - About the dimension of the active area(A.A.) note1 is excluded. (アクティブエリア(A.A.)の寸法について、note1は適用除外とする。)
 - About the FPC bending should be performed after sufficient evaluation and confirmation that there are no problems. (FPCの折り曲げに関しては、十分な評価を行い問題ないことを確認したうえで行ってください。)
 - Forbidden to hold the FPC strongly and make it wrinkled. (FPCを強く折り曲げて、癖を付けるのは禁止)

Material 材質	Treatment 処理	Approved '19.08.21	Checked	Checked '19.08.21	Drawn	Scale 5:1(10:1)	Title TN0104ANVAANN-GN00		Year-Month-Day '19.08.19	Size 2
Quantity 製作数	Description; 備考	RoHS 19023-01717	宇佐美	倉元	蔭山	Outline Dimensions	Drawing No. 121A9009000-1			