

22ECP60 Ultra EC™

Ø 22 mm • 2-pole • 120 W

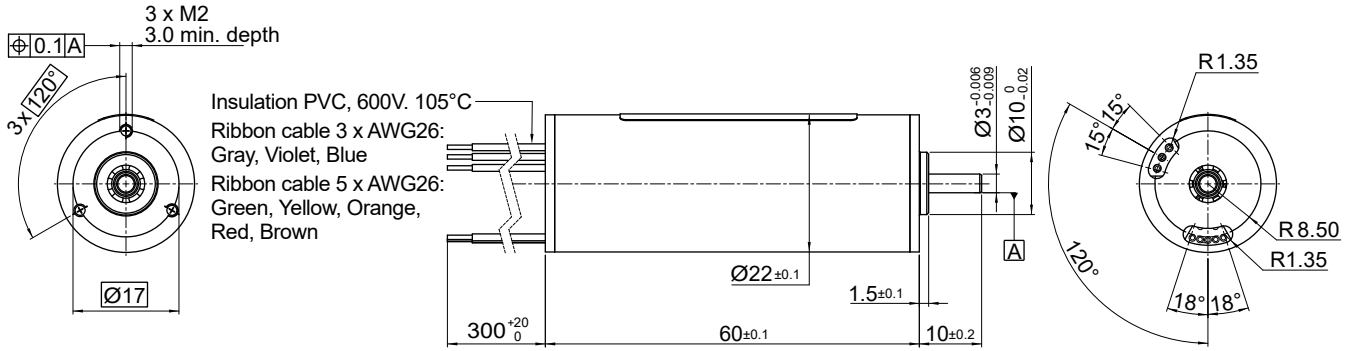

Dimensions in mm.

Electrical Data	Symbol	22ECP60 8B-90.01	Unit
1 Nominal Voltage	U_N	24	Volt
2 Optimization Direction	-	Symmetrical	-
3 No Load Speed	n_0	8,050	rpm
4 Typical No Load Current	I_o	40	mA
5 Max. Continuous Mechanical Power (@25°C)	P_{max}	120	W
6 Max. Continuous Current	$I_{e,max}$	1.8	A
7 Max. Continuous Torque	$M_{e,max}$	50.5 (7.16)	mNm (oz-in)
8 Back EMF Constant	k_E	2.96	V/1000 rpm
9 Torque Constant	k_M	28.3	mNm/A
10 Motor Regulation	R/k^2	3.0	10 ³ /Nms
11 Motor Regulation	$k/R^{1/2}$	18.3 (2.6)	mNm/W ^{1/2} (oz-in/W ^{1/2})
12 Internal Resistance - phase to phase	R_1	2.38	ohms
13 Line to Line Resistance at Connectors	R_L	2.47	ohms
14 Inductance Phase to Phase	L	0.48	mH
15 Mechanical Time Constant	τ_m	1.0	ms
16 Electrical Time Constant	τ_e	0.20	ms

General Data			
17 Maximum Motor Speed	n_{max}	38000	rpm
18 Ambient Working Temperature Range	-	-30 to + 100 (-22 to + 212)	°C (°F)
19 Ambient Storage Temperature Range	-	-40 to + 100 (-40 to + 212)	°C (°F)
20 Ball Bearings Preload	-	5.50	N
21 Axial Static Force w/o Shaft Support (max)	-	34	N
22 Maximum Winding Temperature	-	125 (257)	°C (°F)
23 Thermal Resistance	R_{th}	1/8.4	°C/W
24 Thermal Time Constant	τ_w	1100	s
25 Weight	-	140 (4.94)	g (oz)
26 Rotor Inertia	J	3.5	g-cm ²
27 Hall Sensor Electrical Phasing*	-	120	Electrical °

*Available without hall sensor

Wire	Description
Gray	Phase 1
Violet	Phase 2
Blue	Phase 3
Green	3.5 to 24V DC
Yellow	GND
Orange	Sensor 1
Red	Sensor 2
Brown	Sensor 3

with hall effect sensor

