

PRODUCT NUMBER

SEE TABLE

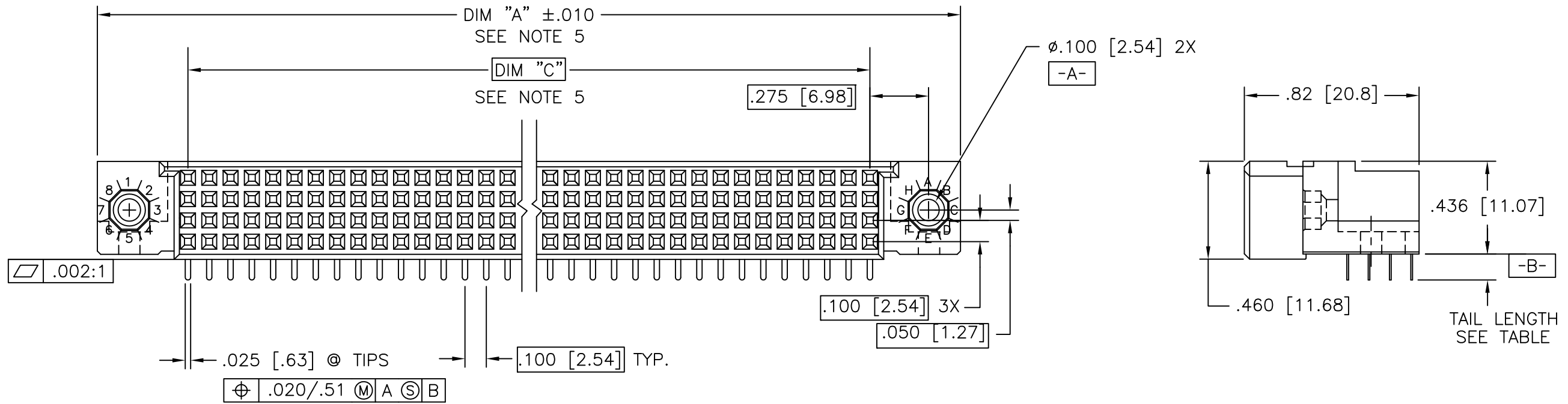
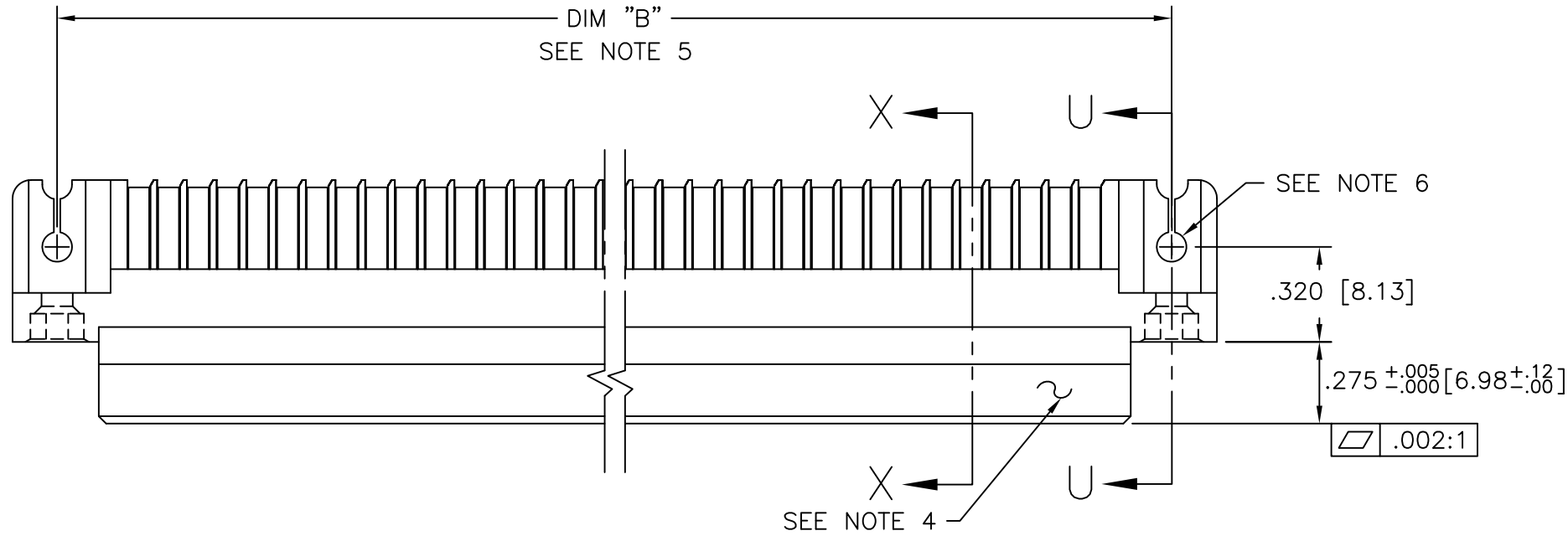

mat'l. code		surface		tolerance		projection		product family	
NOTE 3		ISO 1302 ✓		ISO 406 ISO 1101				HPC	
ltr	ecn no	dr	date	tolerances unless otherwise specified		INCH/MM		title	
T	ELX-I-26895	MJA	05/03/17	angles	linear			4 ROW R/A RECEPTACLE SOLDER TAIL, 0 GUIDE PIN	
-	-	-	-	0°±2'		scale 1:1		dwg no	
M	V05-0207	VS	3/2/05					sheet 1 of 5 size	
N	V05-1052	HTB	12/7/05	dr	G.PETERS	6/4/96		50295	
P	M06-0283	MHT	7/27/06	enr	S.CLARK	6/3/96		A3	
R	M07-0099	AGS	2/09/07	chr	M JACOB	05/03/17		type	
S	M08-0280	AGS	9/30/08	appd	BIJU K PAUL	05/03/17		Product Customer Drawing	
sheet	revision	T	T	T	S	S			
index	sheet	1	2	3	4	5			

PRODUCT NUMBER  
SEE TABLE

NOTES:

- ① PRODUCT NUMBERING CODE:  
50295 - X YYY Z S LF  
LEAD FREE (OPTIONAL)  
SPECIAL FEATURES (NOTE 6)  
TAIL LENGTH (SEE TABLE)  
NO. OF POSITIONS (NOTE 2)  
PLATING (SEE TABLE)  
BASE NUMBER
- ② THIS PRODUCT IS CONFIGURED IN SIZES OF 6 thru 80 COLUMNS IN INCREMENTS OF ONE.  
i.e.: 6,7,8,9.....79,80.
- ③ HOUSING MATERIAL: GLASS & MINERAL FILLED HIGH-TEMP THERMOPLASTIC, FLAME RETARDANT PER UL94 V-0.  
CONTACT MATERIAL: BeCu
- ④ MANUFACTURE'S NAME, PART NUMBER AND LOT CODE TO APPEAR ON THIS SURFACE PER BUS-12-108.
- ⑤ LENGTH DIMENSION FORMULAS:  
DIM "A" =  $.100/2.54 \times \text{NO. OF COLUMNS} + .75/19.1$   
DIM "B" =  $.100/2.54 \times \text{NO. OF COLUMNS} + .450/11.43$   
DIM "C" =  $.100/2.54 \times \text{NO. OF COLUMNS} - .100/2.54$
- ⑥ SPECIAL FEATURES (SEE SHEET 3) AND TABLE.  
- = IF CODE IS OMITTED FROM PRODUCT NUMBER: CONNECTOR IS PROVIDED AS SHOWN, NO SPECIAL FEATURES ARE SELECTED. FOR P.C.B. ATTACHMENT IN A  $\phi.120[3.05]$  MOUNTING HOLE.  
"A" = IF SPECIFIED, PRE-INSTALLED CLAW FOR P.C.B. ATTACHMENT IN A  $\phi.100[2.54]$  MOUNTING HOLE. AVAILABLE IN "E" TAIL LENGTH ONLY.  
"B" = IF SPECIFIED, PRE-INSTALLED CLAW FOR P.C.B. ATTACHMENT IN A  $\phi.120[3.05]$  MOUNTING HOLE.  
"C" = IF SPECIFIED, MOLDED GUIDE PINS WITH PRE-INSTALLED CLAW FOR P.C.B. ATTACHMENT IN A  $\phi.120[3.05]$  MOUNTING HOLE.  
"D" = IF SPECIFIED, MOLDED GUIDE PINS WITH  $\phi.100[2.54]$  MOUNTING HOLE (NO CLAW).
- ⑦ CLAW DIMENSION DETERMINED BY P.C.B. HOLE DIAMETER.
8. THIS PRODUCT (WITH "LF" SUFFIX) MEETS EUROPEAN UNION DIRECTIVES AND OTHER COUNTRY REGULATIONS AS DESCRIBED IN GS-22-008.
9. THIS HOUSING WILL WITHSTAND EXPOSURE TO 260 DEGREES C PEAK TEMPERATURE FOR 10-30 SECONDS IN A CONVECTION, INFRA-RED OR VAPOR PHASE REFLOW OVEN.
- ⑩ PLATING OPTION:  
MAY BE EITHER GOLD OR GXT PLATED AT MANUFACTURER'S OPTION.

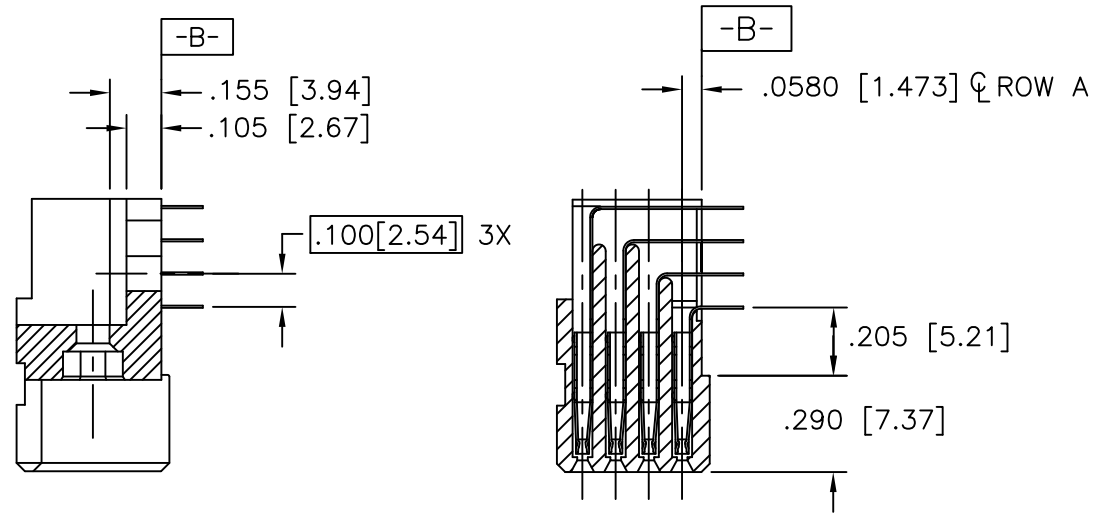

SECTION U-U NO SPECIAL FEATURE  
SECTION X-X

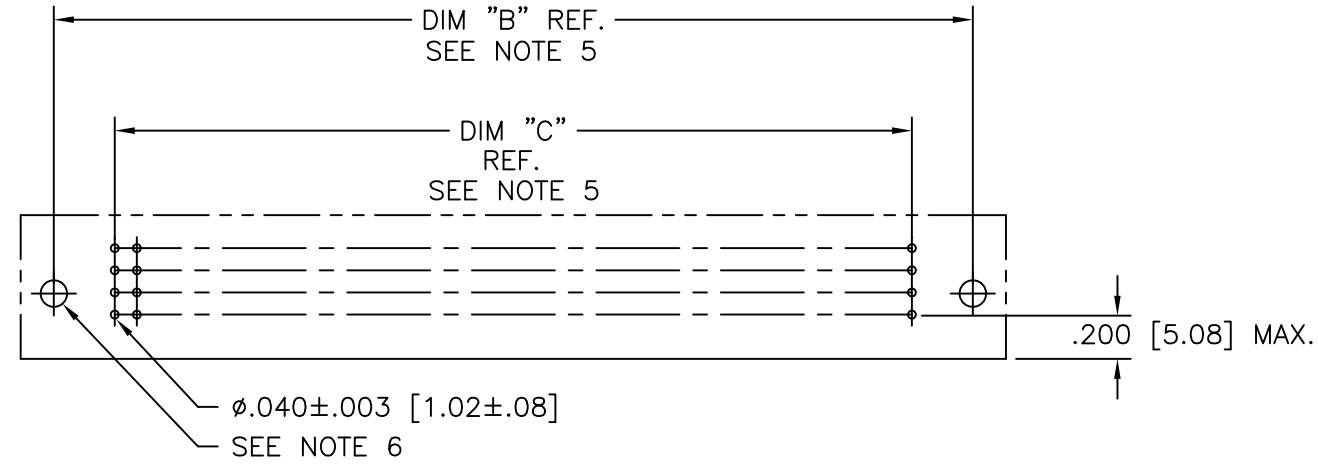

RECOMMENDED PCB LAYOUT  
(ALL HOLES LOCATED ON  $.100 [2.54]$  GRID UNLESS OTHERWISE SPECIFIED)

mat'l. code NOTE 3		surface ISO 1302 ✓	tolerance ISO 406 ISO 1101	projection INCH/MM	product family HPC
ltr	ecn no	dr	date	tolerances unless otherwise specified	title 4 ROW R/A RECEPTACLE SOLDER TAIL, 0 GUIDE PIN
T				angles linear XX±.01/XX±0.3 XXX±.005/XX±0.13 XXXX±.0020/XXX±0.051	
				0°±2°	
		dr	G.PETERS	6/4/96	dwg no 50295 sheet 2 of 5 size A3
		enr	S.CLARK	6/3/96	
		chr	M JACOB	05/03/17	
		appd	BIJU K PAUL	05/03/17	
sheet index	revision sheet				type Product Customer Drawing

PRODUCT NUMBER

SEE TABLE

SPECIAL FEATURE OPTION A

SPECIAL FEATURE OPTION B

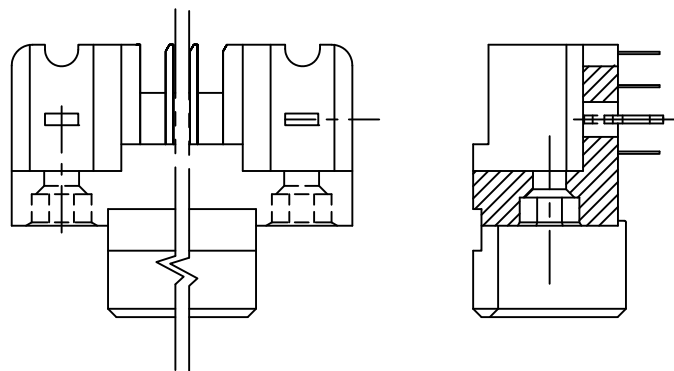

SECTION U-U

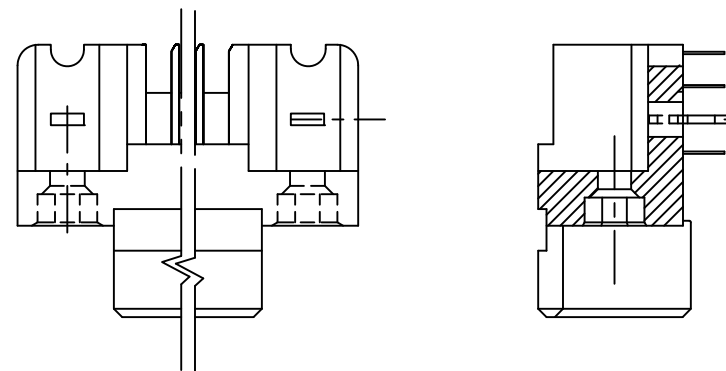

SECTION U-U

SPECIAL FEATURE OPTION C

SPECIAL FEATURE OPTION D

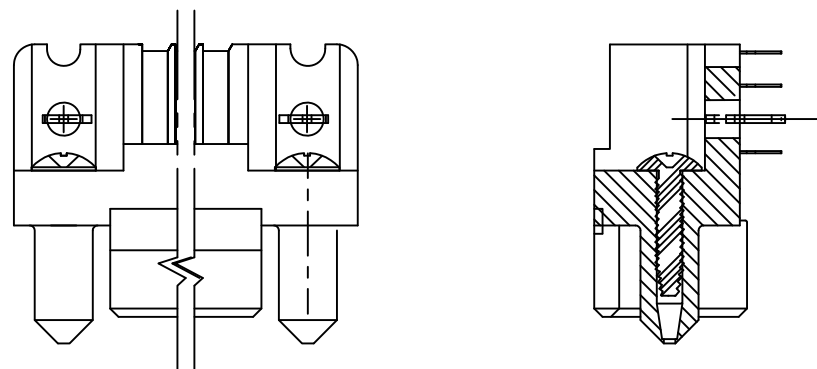

SECTION U-U

SELF TAPPING SCREW (2x)

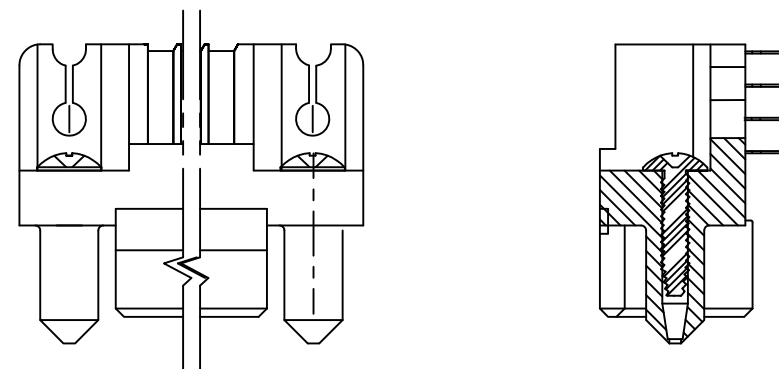

SECTION U-U

SELF TAPPING SCREW (2x)

NOTE 7

Amphenol FCI

Copyright AFCl

mat'l. code NOTE 3		surface ISO 1302 ✓	tolerance ISO 406 ISO 1101	projection 	product family HPC
ltr	ecn no	dr	date	tolerances unless otherwise specified	title 4 ROW R/A RECEPTACLE SOLDER TAIL, 0 GUIDE PIN
T				angles linear .XX±.01/.X±0.3 .XXX±.005/.XX±0.13 .XXXX±.0020/.XXX±0.051	
				0°±2°	
		dr	G.PETERS	6/4/96	dwg no 50295
		enr	S.CLARK	6/3/96	
		chr	M JACOB	05/03/17	sheet 3 of 5 size A3
		appd	BIJU K PAUL	05/03/17	
sheet index		revision sheet			type Product Customer Drawing

PRODUCT NUMBER NOTE 1 AND 2	NUMBER OF POSITIONS SEE NOTE 2	TAIL LENGTH ±.010/0.25	SPECIAL FEATURES SEE NOTE 6	TAIL PLATING	CONTACT PLATING SEE NOTE 10	PRODUCT NUMBER NOTE 1 AND 2	NUMBER OF POSITIONS SEE NOTE 2	TAIL LENGTH ±.010/0.25	SPECIAL FEATURES SEE NOTE 6	TAIL PLATING	CONTACT PLATING SEE NOTE 10
50295-1YYYE	YYY	.125/3.18	NONE	TIN-LEAD	30μ"/0.76μ Au	50295-1YYYELF	YYY	.125/3.18	NONE	TIN	30μ"/0.76μ Au
50295-1YYYEA	YYY	.125/3.18	"A"		30μ"/0.76μ Au	50295-1YYYEALF	YYY	.125/3.18	"A"		30μ"/0.76μ Au
50295-1YYYEB	YYY	.125/3.18	"B"		30μ"/0.76μ Au	50295-1YYYEBLF	YYY	.125/3.18	"B"		30μ"/0.76μ Au
50295-1YYYEC	YYY	.125/3.18	"C"		30μ"/0.76μ Au	50295-1YYYECLF	YYY	.125/3.18	"C"		30μ"/0.76μ Au
50295-1YYYED	YYY	.125/3.18	"D"		30μ"/0.76μ Au	50295-1YYYEDLF	YYY	.125/3.18	"D"		30μ"/0.76μ Au
50295-1YYYF	YYY	.145/3.68	NONE		30μ"/0.76μ Au	50295-1YYYFLF	YYY	.145/3.68	NONE		30μ"/0.76μ Au
50295-1YYYFB	YYY	.145/3.68	"B"		30μ"/0.76μ Au	50295-1YYYFBLF	YYY	.145/3.68	"B"		30μ"/0.76μ Au
50295-1YYYFC	YYY	.145/3.68	"C"		30μ"/0.76μ Au	50295-1YYYFCLF	YYY	.145/3.68	"C"		30μ"/0.76μ Au
50295-1YYYFD	YYY	.145/3.68	"D"		30μ"/0.76μ Au	50295-1YYYFDLF	YYY	.145/3.68	"D"		30μ"/0.76μ Au
50295-1YYYH	YYY	.180/4.57	NONE		30μ"/0.76μ Au	50295-1YYYHLF	YYY	.180/4.57	NONE		30μ"/0.76μ Au
50295-1YYYHB	YYY	.180/4.57	"B"		30μ"/0.76μ Au	50295-1YYYHBLF	YYY	.180/4.57	"B"		30μ"/0.76μ Au
50295-1YYYHC	YYY	.180/4.57	"C"		30μ"/0.76μ Au	50295-1YYYHCLF	YYY	.180/4.57	"C"		30μ"/0.76μ Au
50295-1YYYHD	YYY	.180/4.57	"D"		30μ"/0.76μ Au	50295-1YYYHDLF	YYY	.180/4.57	"D"		30μ"/0.76μ Au
50295-3YYYE	YYY	.125/3.18	NONE		50μ"/1.27μ Au	50295-3YYYELF	YYY	.125/3.18	NONE		50μ"/1.27μ Au
50295-3YYYEA	YYY	.125/3.18	"A"		50μ"/1.27μ Au	50295-3YYYEALF	YYY	.125/3.18	"A"		50μ"/1.27μ Au
50295-3YYYEB	YYY	.125/3.18	"B"		50μ"/1.27μ Au	50295-3YYYEBLF	YYY	.125/3.18	"B"		50μ"/1.27μ Au
50295-3YYYEC	YYY	.125/3.18	"C"		50μ"/1.27μ Au	50295-3YYYECLF	YYY	.125/3.18	"C"		50μ"/1.27μ Au
50295-3YYYED	YYY	.125/3.18	"D"		50μ"/1.27μ Au	50295-3YYYEDLF	YYY	.125/3.18	"D"		50μ"/1.27μ Au
50295-3YYYF	YYY	.145/3.68	NONE		50μ"/1.27μ Au	50295-3YYYFLF	YYY	.145/3.68	NONE		50μ"/1.27μ Au
50295-3YYYFB	YYY	.145/3.68	"B"		50μ"/1.27μ Au	50295-3YYYFBLF	YYY	.145/3.68	"B"		50μ"/1.27μ Au
50295-3YYYFC	YYY	.145/3.68	"C"		50μ"/1.27μ Au	50295-3YYYFCLF	YYY	.145/3.68	"C"		50μ"/1.27μ Au
50295-3YYYFD	YYY	.145/3.68	"D"		50μ"/1.27μ Au	50295-3YYYFDLF	YYY	.145/3.68	"D"		50μ"/1.27μ Au
50295-3YYYH	YYY	.180/4.57	NONE		50μ"/1.27μ Au	50295-3YYYHLF	YYY	.180/4.57	NONE		50μ"/1.27μ Au
50295-3YYYHB	YYY	.180/4.57	"B"		50μ"/1.27μ Au	50295-3YYYHBLF	YYY	.180/4.57	"B"		50μ"/1.27μ Au
50295-3YYYHC	YYY	.180/4.57	"C"		50μ"/1.27μ Au	50295-3YYYHCLF	YYY	.180/4.57	"C"		50μ"/1.27μ Au
50295-3YYYHD	YYY	.180/4.57	"D"	TIN-LEAD	50μ"/1.27μ Au	50295-3YYYHDLF	YYY	.180/4.57	"D"	TIN	50μ"/1.27μ Au

TABLE CONTINUED ON SHEET 5

Amphenol  
FCi

Copyright AFci

mat'l. code NOTE 3				surface ISO 1302 ✓		tolerance ISO 406 ISO 1101		projection 		product family HPC					
ltr	ecn no	dr	date	tolerances unless otherwise specified								title			
S				angles		linear		INCH/MM		4 ROW R/A RECEPTACLE SOLDER TAIL, 0 GUIDE PIN					
				0°±2°				scale 1:1		dwg no 50295					
				dr		G.PETERS		6/4/96		sheet 4 of 5		size A3			
				enr		S.CLARK		6/3/96		Amphenol FCi		Product Customer Drawing			
				chr		S.CLARK		6/4/96							
				appd		S.CLARK		6/4/96							
sheet index		revision sheet													

PRODUCT NUMBER NOTE 1 AND 2	NUMBER OF POSITIONS SEE NOTE 2	TAIL LENGTH ±.010/0.25	SPECIAL FEATURES SEE NOTE 6	TAIL PLATING	CONTACT PLATING SEE NOTE 10
50295-5YYYE	YYY	.125/3.18	NONE	TIN/LEAD	30μ"/0.76μ GXT
50295-5YYYELF	YYY	.125/3.18	NONE	TIN	
50295-5YYYEA	YYY	.125/3.18	"A"	TIN/LEAD	
50295-5YYYEALF	YYY	.125/3.18	"A"	TIN	
50295-5YYYEB	YYY	.125/3.18	"B"	TIN/LEAD	
50295-5YYYEBLF	YYY	.125/3.18	"B"	TIN	
50295-5YYYEC	YYY	.125/3.18	"C"	TIN/LEAD	
50295-5YYYECLF	YYY	.125/3.18	"C"	TIN	
50295-5YYYED	YYY	.125/3.18	"D"	TIN/LEAD	
50295-5YYYEDLF	YYY	.125/3.18	"D"	TIN	
50295-5YYYF	YYY	.145/3.68	NONE	TIN/LEAD	
50295-5YYYFLF	YYY	.145/3.68	NONE	TIN	
50295-5YYYFB	YYY	.145/3.68	"B"	TIN/LEAD	
50295-5YYYFBLF	YYY	.145/3.68	"B"	TIN	
50295-5YYYFC	YYY	.145/3.68	"C"	TIN/LEAD	
50295-5YYYFCLF	YYY	.145/3.68	"C"	TIN	
50295-5YYYFD	YYY	.145/3.68	"D"	TIN/LEAD	
50295-5YYYFDLF	YYY	.145/3.68	"D"	TIN	
50295-5YYYH	YYY	.180/4.57	NONE	TIN/LEAD	
50295-5YYYHLF	YYY	.180/4.57	NONE	TIN	
50295-5YYYHB	YYY	.180/4.57	"B"	TIN/LEAD	
50295-5YYYHBLF	YYY	.180/4.57	"B"	TIN	
50295-5YYYHC	YYY	.180/4.57	"C"	TIN/LEAD	
50295-5YYYHCLF	YYY	.180/4.57	"C"	TIN	
50295-5YYYHD	YYY	.180/4.57	"D"	TIN/LEAD	
50295-5YYYHDLF	YYY	.180/4.57	"D"	TIN	30μ"/0.76μ GXT

Amphenol  
FCI

Copyright AFCl

mat'l. code NOTE 3		surface ISO 1302 ✓	tolerance ISO 406 ISO 1101	projection 	product family HPC
ltr	ecn no	dr	date	title	
s				4 ROW R/A RECEPTACLE SOLDER TAIL, 0 GUIDE PIN	
		tolerances unless otherwise specified		INCH/MM	
		angles	linear	scale 1:1	
		0°±2°	.XX±.01/.X±0.3 .XXX±.005/.XX±0.13 .XXXX±.0020/.XXX±0.051		
dr	G.PETERS	6/4/96		Amphenol FCI	dwg no
enr	S.CLARK	6/3/96			sheet 5 of 5 size
chr	S.CLARK	6/4/96			50295
appd	S.CLARK	6/4/96			A3
sheet index		revision sheet			type Product Customer Drawing