

IGLOO nano Low Power Flash FPGAs with Flash*Freeze Technology

Features and Benefits

Low Power

- nanoPower Consumption—Industry's Lowest Power
- 1.2 V to 1.5 V Core Voltage Support for Low Power
- Supports Single-Voltage System Operation
- Low Power Active FPGA Operation
- Flash*Freeze Technology Enables Ultra-Low Power Consumption while Maintaining FPGA Content
- Easy Entry to / Exit from Ultra-Low Power Flash*Freeze Mode

Small Footprint Packages

- As Small as 3x3 mm in Size

Wide Range of Features

- 10,000 to 250,000 System Gates
- Up to 36 kbits of True Dual-Port SRAM
- Up to 71 User I/Os

Reprogrammable Flash Technology

- 130-nm, 7-Layer Metal, Flash-Based CMOS Process
- Instant On Level 0 Support
- Single-Chip Solution
- Retains Programmed Design When Powered Off
- 250 MHz (1.5 V systems) and 160 MHz (1.2 V systems) System Performance

In-System Programming (ISP) and Security

- ISP Using On-Chip 128-Bit Advanced Encryption Standard (AES) Decryption via JTAG (IEEE 1532-compliant)
- FlashLock[®] Designed to Secure FPGA Contents
- 1.2 V Programming

High-Performance Routing Hierarchy

- Segmented, Hierarchical Routing and Clock Structure

Advanced I/Os

- 1.2 V, 1.5 V, 1.8 V, 2.5 V, and 3.3 V Mixed-Voltage Operation
- Bank-Selectable I/O Voltages—up to 4 Banks per Chip
- Single-Ended I/O Standards: LVTTTL, LVCMOS 3.3 V / 2.5 V / 1.8 V / 1.5 V / 1.2 V
- Wide Range Power Supply Voltage Support per JESD8-B, Allowing I/Os to Operate from 2.7 V to 3.6 V
- Wide Range Power Supply Voltage Support per JESD8-12, Allowing I/Os to Operate from 1.14 V to 1.575 V
- I/O Registers on Input, Output, and Enable Paths
- Selectable Schmitt Trigger Inputs
- Hot-Swappable and Cold-Sparing I/Os
- Programmable Output Slew Rate and Drive Strength
- Weak Pull-Up/Down
- IEEE 1149.1 (JTAG) Boundary Scan Test
- Pin-Compatible Packages across the IGLOO[®] Family

Clock Conditioning Circuit (CCC) and PLL[†]

- Up to Six CCC Blocks, One with an Integrated PLL
- Configurable Phase Shift, Multiply/Divide, Delay Capabilities, and External Feedback
- Wide Input Frequency Range (1.5 MHz up to 250 MHz)

Embedded Memory

- 1 kbit of FlashROM User Nonvolatile Memory
- SRAMs and FIFOs with Variable-Aspect-Ratio 4,608-Bit RAM Blocks (x1, x2, x4, x9, and x18 organizations)[†]
- True Dual-Port SRAM (except x18 organization)[†]

Enhanced Commercial Temperature Range

- T_j = -20°C to +85°C

IGLOO nano Devices	AGLN010	AGLN020	AGLN060	AGLN125	AGLN250
System Gates	10,000	20,000	60,000	125,000	250,000
Typical Equivalent Macrocells	86	172	512	1,024	2,048
VersaTiles (D-flip-flops)	260	520	1,536	3,072	6,144
Flash*Freeze Mode (typical, μ W)	2	4	10	16	24
RAM Kbits (1,024 bits) ²	–	–	18	36	36
4,608-Bit Blocks ²	–	–	4	8	8
FlashROM Kbits (1,024 bits)	1	1	1	1	1
Secure (AES) ISP ²	–	–	Yes	Yes	Yes
Integrated PLL in CCCs ^{2,3}	–	–	1	1	1
VersaNet Globals	4	4	18	18	18
I/O Banks	2	3	2	2	4
Maximum User I/Os (packaged device)	34	52	71	71	68
Maximum User I/Os (Known Good Die)	34	52	71	71	68
Package Pins					
UC/CS	UC36	CS81	CS81	CS81	CS81
QFN	QN48	QN68			
VQFP			VQ100	VQ100	VQ100

Notes:

1. AGLN030 and smaller devices do not support this feature.
2. AGLN060, AGLN125, and AGLN250 in the CS81 package do not support PLLs.
3. For higher densities and support of additional features, refer to the [DS0095: IGLOO Low Power Flash FPGAs Datasheet](#) and [IGLOOe Low-Power Flash FPGAs Datasheet](#).

[†] AGLN030 and smaller devices do not support this feature.

I/Os Per Package

IGLOO nano Devices	AGLN010	AGLN020	AGLN060	AGLN125	AGLN250
Known Good Die	34	52	71	71	68
UC36	23	–	–	–	–
QN48	34	–	–	–	–
QN68	–	49	–	–	–
UC81	–	–	–	–	–
CS81	–	52	60	60	60
VQ100	–	–	71	71	68

Notes:

1. When considering migrating your design to a lower- or higher-density device, refer to the [DS0095: IGLOO Low Power Flash FPGAs Datasheet](#) and [IGLOO FPGA Fabric User's Guide](#) to ensure compliance with design and board migration requirements.
2. When the Flash*Freeze pin is used to directly enable Flash*Freeze mode and not used as a regular I/O, the number of single-ended user I/Os available is reduced by one.
3. "G" indicates RoHS-compliant packages. Refer to ["IGLOO nano Ordering Information"](#) on [page IV](#) for the location of the "G" in the part number. For nano devices, the VQ100 package is offered in both leaded and RoHS-compliant versions. All other packages are RoHS-compliant only.

Table 1 • IGLOO nano FPGAs Package Sizes Dimensions

Packages	UC36	UC81	CS81	QN48	QN68	VQ100
Length × Width (mm\mm)	3 x 3	4 x 4	5 x 5	6 x 6	8 x 8	14 x 14
Nominal Area (mm ²)	9	16	25	36	64	196
Pitch (mm)	0.4	0.4	0.5	0.4	0.4	0.5
Height (mm)	0.80	0.80	0.80	0.90	0.90	1.20

IGLOO nano Device Status

IGLOO nano Devices	Status	IGLOO nano-Z Devices	Status
AGLN010	Production		
AGLN020	Production		
AGLN060	Production		
AGLN125	Production		
AGLN250	Production		

IGLOO nano Ordering Information

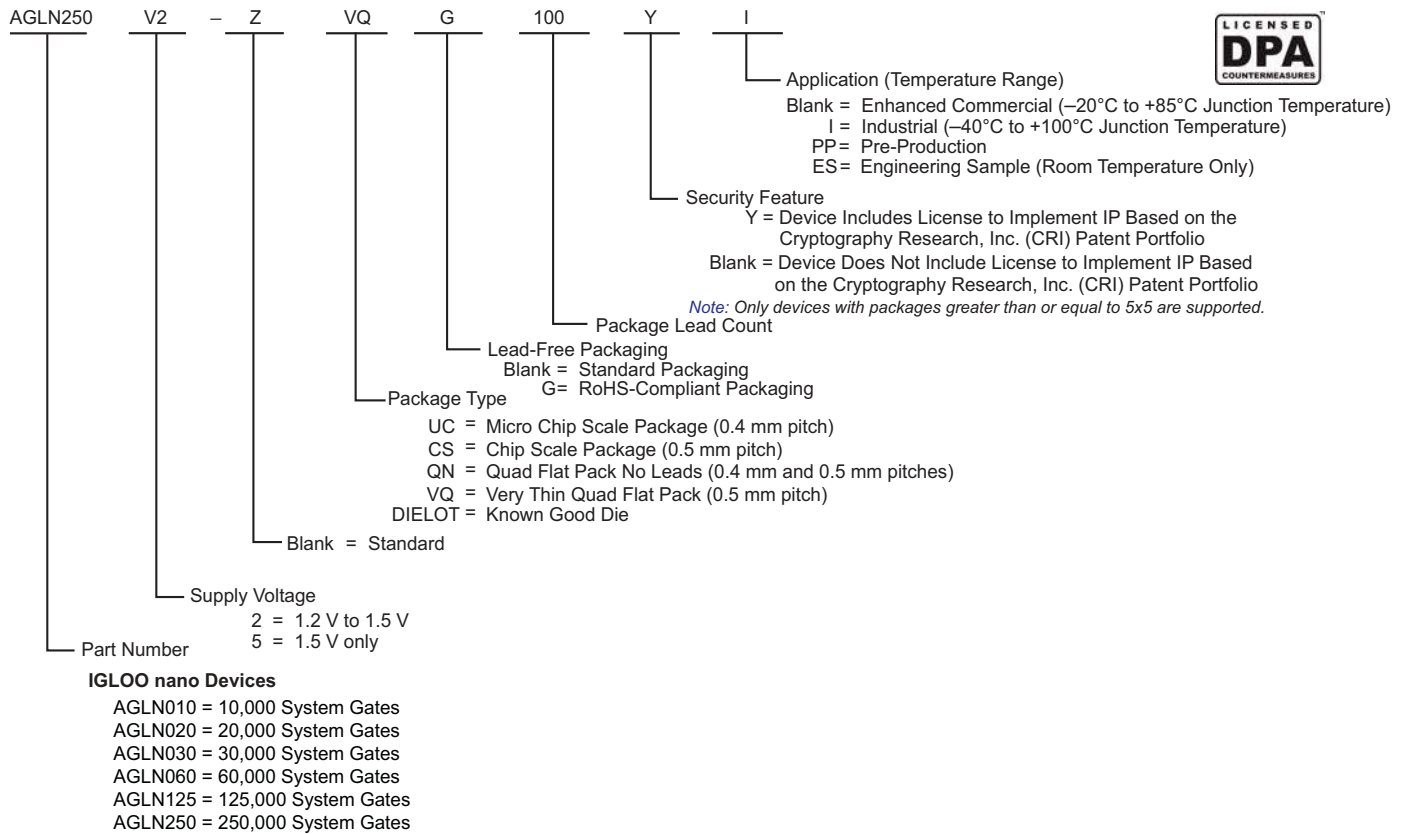

Notes:

1. **Marking Information:** IGLOO nano V2 devices do not have a V2 marking, but IGLOO nano V5 devices are marked with a V5 designator.

Devices Not Recommended For New Designs

Device Marking

Microsemi normally topside marks the full ordering part number on each device. There are some exceptions to this, such as the V2 designator for IGLOO devices and packages where space is physically limited. Packages that have limited characters available are UC36, UC81, CS81, QN48, QN68, and QFN132. On these specific packages, a subset of the device marking will be used that includes the required legal information and as much of the part number as allowed by character limitation of the device. In this case, devices will have a truncated device marking and may exclude the applications markings, such as the I designator for Industrial Devices or the ES designator for Engineering Samples.

Figure 1 shows an example of device marking based on the AGLN250V2-CSG81. The actual mark will vary by the device/package combination ordered.

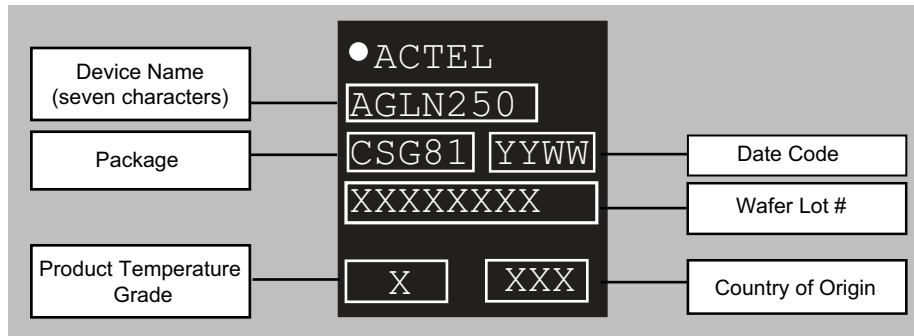

Figure 1 • Example of Device Marking for Small Form Factor Packages

Temperature Grade Offerings

Package	AGLN010	AGLN020	AGLN060	AGLN125	AGLN250
UC36	C, I	–	–	–	–
QN48	C, I	–	–	–	–
QN68	–	C, I	–	–	–
UC81	–	–	–	–	–
CS81	–	C, I	C, I	C, I	C, I
VQ100	–	–	C, I	C, I	C, I

C = Enhanced Commercial temperature range: -20°C to $+85^{\circ}\text{C}$ junction temperature

I = Industrial temperature range: -40°C to $+100^{\circ}\text{C}$ junction temperature

Contact your local Microsemi representative for device availability: <http://www.microsemi.com/soc/contact/default.aspx>.

Table of Contents

IGLOO nano Device Overview

General Description	1-1
---------------------------	-----

IGLOO nano DC and Switching Characteristics

General Specifications	2-1
Calculating Power Dissipation	2-7
User I/O Characteristics	2-15
VersaTile Characteristics	2-57
Global Resource Characteristics	2-63
Clock Conditioning Circuits	2-70
Embedded SRAM and FIFO Characteristics	2-73
Embedded FlashROM Characteristics	2-87
JTAG 1532 Characteristics	2-88

Pin Descriptions

Supply Pins	3-1
User Pins	3-2
JTAG Pins	3-3
Special Function Pins	3-4
Packaging	3-4
Related Documents	3-5

Package Pin Assignments

UC36	4-1
UC81	4-3
CS81	4-4
QN48	4-9
QN68	4-11
VQ100	4-13

Datasheet Information

List of Changes	5-1
Datasheet Categories	5-10
Safety Critical, Life Support, and High-Reliability Applications Policy	5-10

1 – IGLOO nano Device Overview

General Description

The IGLOO family of flash FPGAs, based on a 130-nm flash process, offers the lowest power FPGA, a single-chip solution, small footprint packages, reprogrammability, and an abundance of advanced features.

The Flash*Freeze technology used in IGLOO nano devices enables entering and exiting an ultra-low power mode that consumes nanoPower while retaining SRAM and register data. Flash*Freeze technology simplifies power management through I/O and clock management with rapid recovery to operation mode.

The Low Power Active capability (static idle) allows for ultra-low power consumption while the IGLOO nano device is completely functional in the system. This allows the IGLOO nano device to control system power management based on external inputs (e.g., scanning for keyboard stimulus) while consuming minimal power.

Nonvolatile flash technology gives IGLOO nano devices the advantage of being a secure, low power, single-chip solution that is Instant On. The IGLOO nano device is reprogrammable and offers time-to-market benefits at an ASIC-level unit cost.

These features enable designers to create high-density systems using existing ASIC or FPGA design flows and tools.

IGLOO nano devices offer 1 kbit of on-chip, reprogrammable, nonvolatile FlashROM storage as well as clock conditioning circuitry based on an integrated phase-locked loop (PLL). The AGLN030 and smaller devices have no PLL or RAM support. IGLOO nano devices have up to 250 k system gates, supported with up to 36 kbits of true dual-port SRAM and up to 71 user I/Os.

IGLOO nano devices increase the breadth of the IGLOO product line by adding new features and packages for greater customer value in high volume consumer, portable, and battery-backed markets. Features such as smaller footprint packages designed with two-layer PCBs in mind, power consumption measured in nanoPower, Schmitt trigger, and bus hold (hold previous I/O state in Flash*Freeze mode) functionality make these devices ideal for deployment in applications that require high levels of flexibility and low cost.

Flash*Freeze Technology

The IGLOO nano device offers unique Flash*Freeze technology, allowing the device to enter and exit ultra-low power Flash*Freeze mode. IGLOO nano devices do not need additional components to turn off I/Os or clocks while retaining the design information, SRAM content, and registers. Flash*Freeze technology is combined with in-system programmability, which enables users to quickly and easily upgrade and update their designs in the final stages of manufacturing or in the field. The ability of IGLOO nano V2 devices to support a wide range of core voltage (1.2 V to 1.5 V) allows further reduction in power consumption, thus achieving the lowest total system power.

During Flash*Freeze mode, each I/O can be set to the following configurations: hold previous state, tristate, HIGH, or LOW.

The availability of low power modes, combined with reprogrammability, a single-chip and single-voltage solution, and small-footprint packages make IGLOO nano devices the best fit for portable electronics.

Flash Advantages

Low Power

Flash-based IGLOO nano devices exhibit power characteristics similar to those of an ASIC, making them an ideal choice for power-sensitive applications. IGLOO nano devices have only a very limited power-on current surge and no high-current transition period, both of which occur on many FPGAs.

IGLOO nano devices also have low dynamic power consumption to further maximize power savings; power is reduced even further by the use of a 1.2 V core voltage.

Low dynamic power consumption, combined with low static power consumption and Flash*Freeze technology, gives the IGLOO nano device the lowest total system power offered by any FPGA.

Security

Nonvolatile, flash-based IGLOO nano devices do not require a boot PROM, so there is no vulnerable external bitstream that can be easily copied. IGLOO nano devices incorporate FlashLock, which provides a unique combination of reprogrammability and design security without external overhead, advantages that only an FPGA with nonvolatile flash programming can offer.

IGLOO nano devices utilize a 128-bit flash-based lock and a separate AES key to provide the highest level of security in the FPGA industry for programmed intellectual property and configuration data. In addition, all FlashROM data in IGLOO nano devices can be encrypted prior to loading, using the industry-leading AES-128 (FIPS192) bit block cipher encryption standard. AES was adopted by the National Institute of Standards and Technology (NIST) in 2000 and replaces the 1977 DES standard. IGLOO nano devices have a built-in AES decryption engine and a flash-based AES key that make them the most comprehensive programmable logic device security solution available today. IGLOO nano devices with AES-based security provide a high level of protection for remote field updates over public networks such as the Internet, and are designed to ensure that valuable IP remains out of the hands of system overbuilders, system cloners, and IP thieves.

Security, built into the FPGA fabric, is an inherent component of IGLOO nano devices. The flash cells are located beneath seven metal layers, and many device design and layout techniques have been used to make invasive attacks extremely difficult. IGLOO nano devices, with FlashLock and AES security, are unique in being highly resistant to both invasive and noninvasive attacks. Your valuable IP is protected with industry-standard security, making remote ISP possible. An IGLOO nano device provides the best available security for programmable logic designs.

Single Chip

Flash-based FPGAs store their configuration information in on-chip flash cells. Once programmed, the configuration data is an inherent part of the FPGA structure, and no external configuration data needs to be loaded at system power-up (unlike SRAM-based FPGAs). Therefore, flash-based IGLOO nano FPGAs do not require system configuration components such as EEPROMs or microcontrollers to load device configuration data. This reduces bill-of-materials costs and PCB area, and increases security and system reliability.

Instant On

Microsemi flash-based IGLOO nano devices support Level 0 of the Instant On classification standard. This feature helps in system component initialization, execution of critical tasks before the processor wakes up, setup and configuration of memory blocks, clock generation, and bus activity management. The Instant On feature of flash-based IGLOO nano devices greatly simplifies total system design and reduces total system cost, often eliminating the need for CPLDs and clock generation PLLs. In addition, glitches and brownouts in system power will not corrupt the IGLOO nano device's flash configuration, and unlike SRAM-based FPGAs, the device will not have to be reloaded when system power is restored. This enables the reduction or complete removal of the configuration PROM, expensive voltage monitor, brownout detection, and clock generator devices from the PCB design. Flash-based IGLOO nano devices simplify total system design and reduce cost and design risk while increasing system reliability and improving system initialization time.

IGLOO nano flash FPGAs enable the user to quickly enter and exit Flash*Freeze mode. This is done almost instantly (within 1 μ s) and the device retains configuration and data in registers and RAM. Unlike SRAM-based FPGAs, the device does not need to reload configuration and design state from external memory components; instead it retains all necessary information to resume operation immediately.

Reduced Cost of Ownership

Advantages to the designer extend beyond low unit cost, performance, and ease of use. Unlike SRAM-based FPGAs, flash-based IGLOO nano devices allow all functionality to be Instant On; no external boot PROM is required. On-board security mechanisms prevent access to all the programming information and enable secure remote updates of the FPGA logic.

Designers can perform secure remote in-system reprogramming to support future design iterations and field upgrades with confidence that valuable intellectual property cannot be compromised or copied. Secure ISP can be performed using the industry-standard AES algorithm. The IGLOO nano device architecture mitigates the need for ASIC migration at higher user volumes. This makes IGLOO nano devices cost-effective ASIC replacement solutions, especially for applications in the consumer, networking/communications, computing, and avionics markets.

With a variety of devices under \$1, IGLOO nano FPGAs enable cost-effective implementation of programmable logic and quick time to market.

Firm-Error Immunity

Firm errors occur most commonly when high-energy neutrons, generated in the upper atmosphere, strike a configuration cell of an SRAM FPGA. The energy of the collision can change the state of the configuration cell and thus change the logic, routing, or I/O behavior in an unpredictable way. These errors are impossible to prevent in SRAM FPGAs. The consequence of this type of error can be a complete system failure. Firm errors do not exist in the configuration memory of IGLOO nano flash-based FPGAs. Once it is programmed, the flash cell configuration element of IGLOO nano FPGAs cannot be altered by high-energy neutrons and is therefore immune to them. Recoverable (or soft) errors occur in the user data SRAM of all FPGA devices. These can easily be mitigated by using error detection and correction (EDAC) circuitry built into the FPGA fabric.

Advanced Flash Technology

The IGLOO nano device offers many benefits, including nonvolatility and reprogrammability, through an advanced flash-based, 130-nm LVCMOS process with seven layers of metal. Standard CMOS design techniques are used to implement logic and control functions. The combination of fine granularity, enhanced flexible routing resources, and abundant flash switches allows for very high logic utilization without compromising device routability or performance. Logic functions within the device are interconnected through a four-level routing hierarchy.

IGLOO nano FPGAs utilize design and process techniques to minimize power consumption in all modes of operation.

Advanced Architecture

The proprietary IGLOO nano architecture provides granularity comparable to standard-cell ASICs. The IGLOO nano device consists of five distinct and programmable architectural features ([Figure 1-3 on page 1-5](#) to [Figure 1-4 on page 1-5](#)):

- Flash*Freeze technology
- FPGA VersaTiles
- Dedicated FlashROM
- Dedicated SRAM/FIFO memory[†]
- Extensive CCCs and PLLs[†]
- Advanced I/O structure

The FPGA core consists of a sea of VersaTiles. Each VersaTile can be configured as a three-input logic function, a D-flip-flop (with or without enable), or a latch by programming the appropriate flash switch interconnections. The versatility of the IGLOO nano core tile as either a three-input lookup table (LUT) equivalent or a D-flip-flop/latch with enable allows for efficient use of the FPGA fabric. The VersaTile capability is unique to the ProASIC[®] family of third-generation-architecture flash FPGAs. VersaTiles are connected with any of the four levels of routing hierarchy. Flash switches are distributed throughout the device to provide nonvolatile, reconfigurable interconnect programming. Maximum core utilization is possible for virtually any design.

[†] The AGLN030 and smaller devices do not support PLL or SRAM.

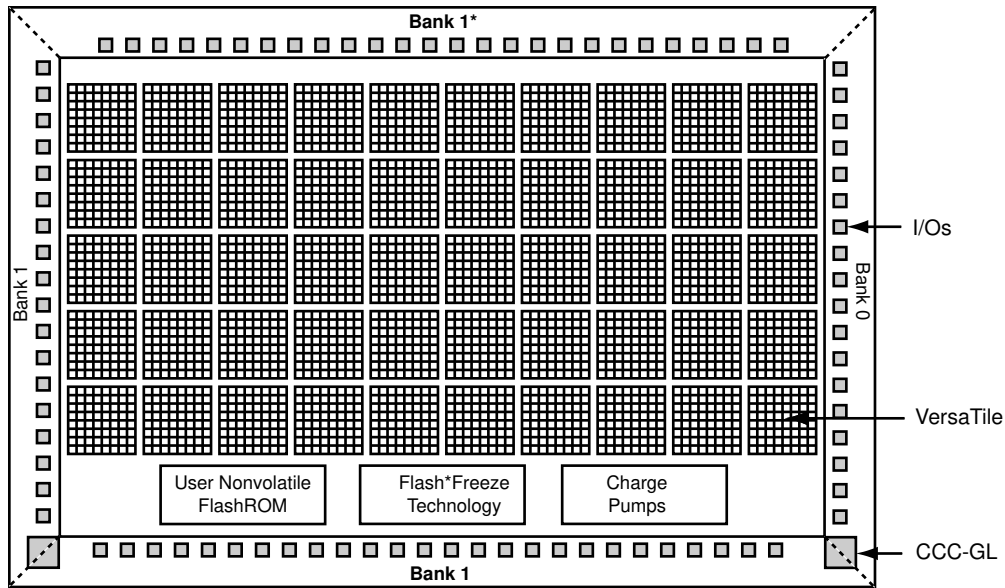

Note: *Bank 0 for the AGLN030 device

Figure 1-1 • IGLOO Device Architecture Overview with Two I/O Banks and No RAM (AGLN010 and AGLN030)

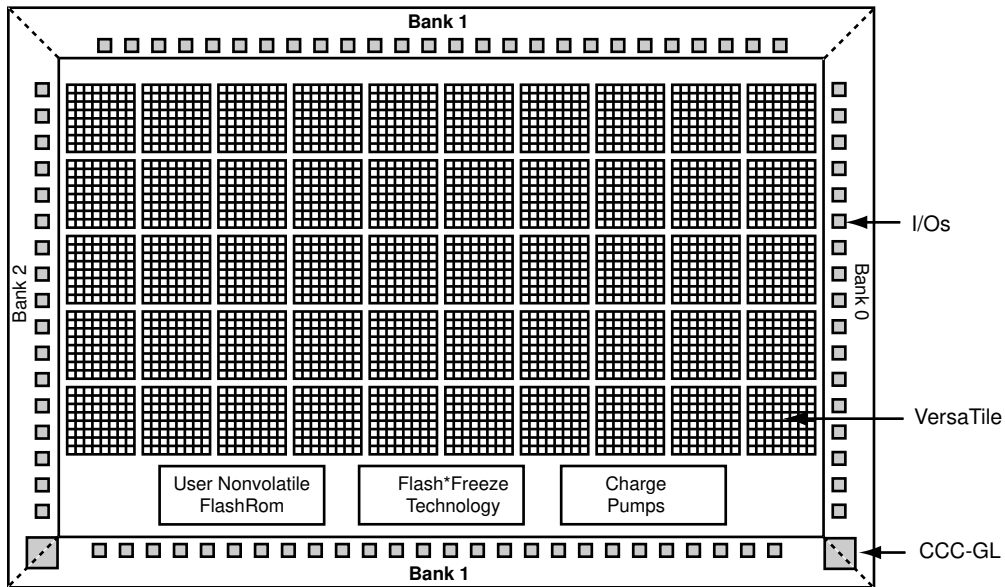

Figure 1-2 • IGLOO Device Architecture Overview with Three I/O Banks and No RAM (AGLN020)

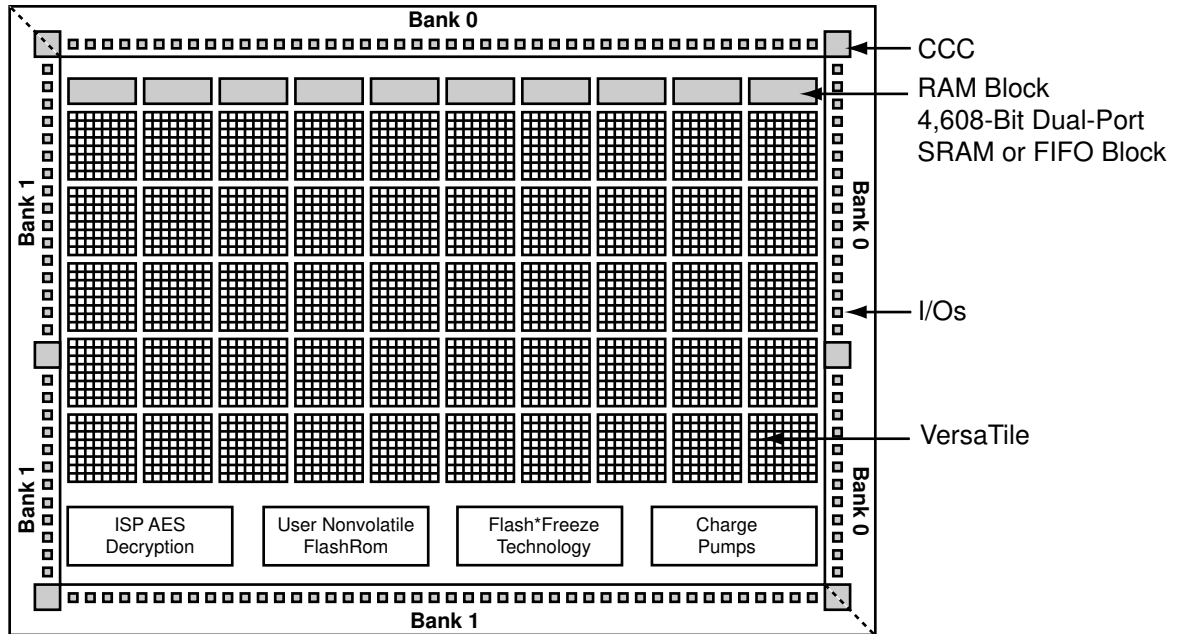

Figure 1-3 • IGLOO Device Architecture Overview with Two I/O Banks (AGLN060, AGLN125)

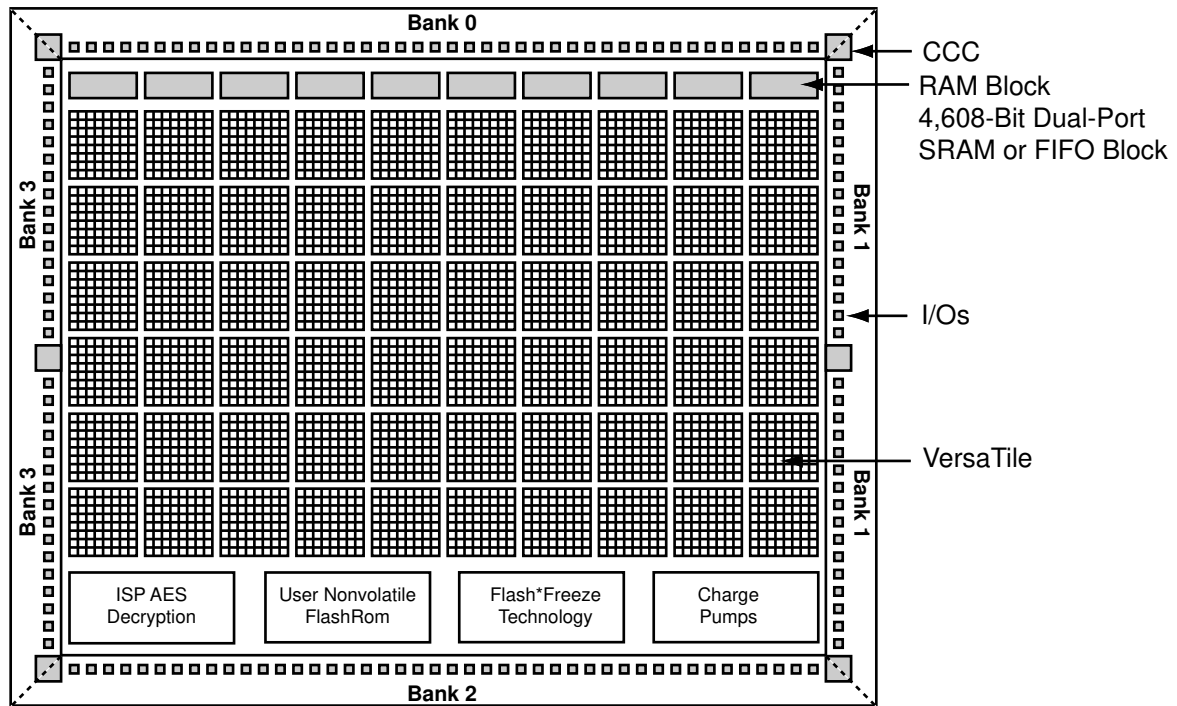

Figure 1-4 • IGLOO Device Architecture Overview with Four I/O Banks (AGLN250)

Flash*Freeze Technology

The IGLOO nano device has an ultra-low power static mode, called Flash*Freeze mode, which retains all SRAM and register information and can still quickly return to normal operation. Flash*Freeze technology enables the user to quickly (within 1 μ s) enter and exit Flash*Freeze mode by activating the Flash*Freeze pin while all power supplies are kept at their original values. I/Os, global I/Os, and clocks can still be driven and can be toggling without impact on power consumption, and the device retains all core registers, SRAM information, and I/O states. I/Os can be individually configured to either hold their previous state or be tristated during Flash*Freeze mode.

Alternatively, I/Os can be set to a specific state using weak pull-up or pull-down I/O attribute configuration. No power is consumed by the I/O banks, clocks, JTAG pins, or PLL, and the device consumes as little as 2 μ W in this mode.

Flash*Freeze technology allows the user to switch to Active mode on demand, thus simplifying the power management of the device.

The Flash*Freeze pin (active low) can be routed internally to the core to allow the user's logic to decide when it is safe to transition to this mode. Refer to [Figure 1-5](#) for an illustration of entering/exiting Flash*Freeze mode. It is also possible to use the Flash*Freeze pin as a regular I/O if Flash*Freeze mode usage is not planned.

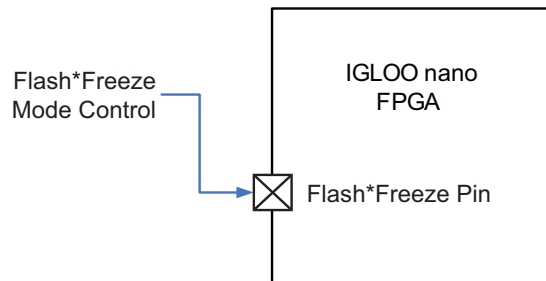

Figure 1-5 • IGLOO nano Flash*Freeze Mode

VersaTiles

The IGLOO nano core consists of VersaTiles, which have been enhanced beyond the ProASIC^{PLUS}® core tiles. The IGLOO nano VersaTile supports the following:

- All 3-input logic functions—LUT-3 equivalent
- Latch with clear or set
- D-flip-flop with clear or set
- Enable D-flip-flop with clear or set

Refer to [Figure 1-6](#) for VersaTile configurations.

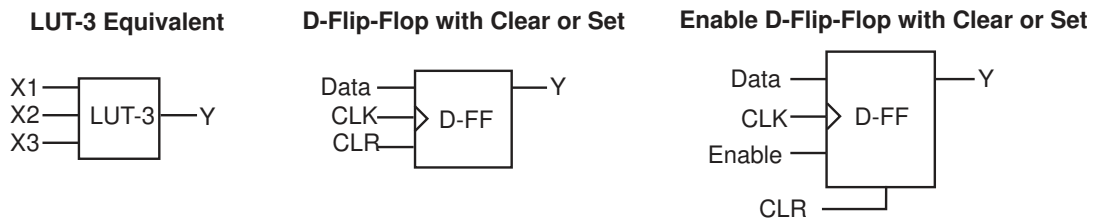

Figure 1-6 • VersaTile Configurations

User Nonvolatile FlashROM

IGLOO nano devices have 1 kbit of on-chip, user-accessible, nonvolatile FlashROM. The FlashROM can be used in diverse system applications:

- Internet protocol addressing (wireless or fixed)
- System calibration settings
- Device serialization and/or inventory control
- Subscription-based business models (for example, set-top boxes)
- Secure key storage for secure communications algorithms
- Asset management/tracking
- Date stamping
- Version management

The FlashROM is written using the standard IGLOO nano IEEE 1532 JTAG programming interface. The core can be individually programmed (erased and written), and on-chip AES decryption can be used selectively to securely load data over public networks (except in the AGLN030 and smaller devices), as in security keys stored in the FlashROM for a user design.

The FlashROM can be programmed via the JTAG programming interface, and its contents can be read back either through the JTAG programming interface or via direct FPGA core addressing. Note that the FlashROM can only be programmed from the JTAG interface and cannot be programmed from the internal logic array.

The FlashROM is programmed as 8 banks of 128 bits; however, reading is performed on a byte-by-byte basis using a synchronous interface. A 7-bit address from the FPGA core defines which of the 8 banks and which of the 16 bytes within that bank are being read. The three most significant bits (MSBs) of the FlashROM address determine the bank, and the four least significant bits (LSBs) of the FlashROM address define the byte.

The IGLOO nano development software solutions, Libero[®] System-on-Chip (SoC) and Designer, have extensive support for the FlashROM. One such feature is auto-generation of sequential programming files for applications requiring a unique serial number in each part. Another feature enables the inclusion of static data for system version control. Data for the FlashROM can be generated quickly and easily using Microsemi Libero SoC and Designer software tools. Comprehensive programming file support is also included to allow for easy programming of large numbers of parts with differing FlashROM contents.

SRAM and FIFO

IGLOO nano devices (except the AGLN030 and smaller devices) have embedded SRAM blocks along their north and south sides. Each variable-aspect-ratio SRAM block is 4,608 bits in size. Available memory configurations are 256×18, 512×9, 1k×4, 2k×2, and 4k×1 bits. The individual blocks have independent read and write ports that can be configured with different bit widths on each port. For example, data can be sent through a 4-bit port and read as a single bitstream. The embedded SRAM blocks can be initialized via the device JTAG port (ROM emulation mode) using the UJTAG macro (except in the AGLN030 and smaller devices).

In addition, every SRAM block has an embedded FIFO control unit. The control unit allows the SRAM block to be configured as a synchronous FIFO without using additional core VersaTiles. The FIFO width and depth are programmable. The FIFO also features programmable Almost Empty (AEMPTY) and Almost Full (AFULL) flags in addition to the normal Empty and Full flags. The embedded FIFO control unit contains the counters necessary for generation of the read and write address pointers. The embedded SRAM/FIFO blocks can be cascaded to create larger configurations.

PLL and CCC

Higher density IGLOO nano devices using either the two I/O bank or four I/O bank architectures provide designers with very flexible clock conditioning capabilities. AGLN060, AGLN125, and AGLN250 contain six CCCs. One CCC (center west side) has a PLL. The AGLN030 and smaller devices use different CCCs in their architecture (CCC-GL). These CCC-GLs contain a global MUX but do not have any PLLs or programmable delays.

For devices using the six CCC block architecture, these are located at the four corners and the centers of the east and west sides. All six CCC blocks are usable; the four corner CCCs and the east CCC allow simple clock delay operations as well as clock spine access.

The inputs of the six CCC blocks are accessible from the FPGA core or from dedicated connections to the CCC block, which are located near the CCC.

The CCC block has these key features:

- Wide input frequency range (f_{IN_CCC}) = 1.5 MHz up to 250 MHz
- Output frequency range (f_{OUT_CCC}) = 0.75 MHz up to 250 MHz
- 2 programmable delay types for clock skew minimization
- Clock frequency synthesis (for PLL only)

Additional CCC specifications:

- Internal phase shift = 0°, 90°, 180°, and 270°. Output phase shift depends on the output divider configuration (for PLL only).
- Output duty cycle = 50% ± 1.5% or better (for PLL only)
- Low output jitter: worst case < 2.5% × clock period peak-to-peak period jitter when single global network used (for PLL only)
- Maximum acquisition time is 300 μs (for PLL only)
- Exceptional tolerance to input period jitter—allowable input jitter is up to 1.5 ns (for PLL only)
- Four precise phases; maximum misalignment between adjacent phases of 40 ps × 250 MHz / f_{OUT_CCC} (for PLL only)

Global Clocking

IGLOO nano devices have extensive support for multiple clocking domains. In addition to the CCC and PLL support described above, there is a comprehensive global clock distribution network.

Each VersaTile input and output port has access to nine VersaNets: six chip (main) and three quadrant global networks. The VersaNets can be driven by the CCC or directly accessed from the core via multiplexers (MUXes). The VersaNets can be used to distribute low-skew clock signals or for rapid distribution of high-fanout nets.

I/Os with Advanced I/O Standards

IGLOO nano FPGAs feature a flexible I/O structure, supporting a range of voltages (1.2 V, 1.2 V wide range, 1.5 V, 1.8 V, 2.5 V, 3.0 V wide range, and 3.3 V).

The I/Os are organized into banks with two, three, or four banks per device. The configuration of these banks determines the I/O standards supported.

Each I/O module contains several input, output, and enable registers. These registers allow the implementation of various single-data-rate applications for all versions of nano devices and double-data-rate applications for the AGLN060, AGLN125, and AGLN250 devices.

IGLOO nano devices support LVTTTL and LVCMOS I/O standards, are hot-swappable, and support cold-sparing and Schmitt trigger.

Hot-swap (also called hot-plug, or hot-insertion) is the operation of hot-insertion or hot-removal of a card in a powered-up system.

Cold-sparing (also called cold-swap) refers to the ability of a device to leave system data undisturbed when the system is powered up, while the component itself is powered down, or when power supplies are floating.

Wide Range I/O Support

IGLOO nano devices support JEDEC-defined wide range I/O operation. IGLOO nano devices support both the JESD8-B specification, covering both 3 V and 3.3 V supplies, for an effective operating range of 2.7 V to 3.6 V, and JESD8-12 with its 1.2 V nominal, supporting an effective operating range of 1.14 V to 1.575 V.

Wider I/O range means designers can eliminate power supplies or power conditioning components from the board or move to less costly components with greater tolerances. Wide range eases I/O bank management and provides enhanced protection from system voltage spikes, while providing the flexibility to easily run custom voltage applications.

Specifying I/O States During Programming

You can modify the I/O states during programming in FlashPro. In FlashPro, this feature is supported for PDB files generated from Designer v8.5 or greater. See the *FlashPro User's Guide* for more information.

Note: PDB files generated from Designer v8.1 to Designer v8.4 (including all service packs) have limited display of Pin Numbers only.

1. Load a PDB from the FlashPro GUI. You must have a PDB loaded to modify the I/O states during programming.
2. From the FlashPro GUI, click PDB Configuration. A FlashPoint – Programming File Generator window appears.
3. Click the Specify I/O States During Programming button to display the Specify I/O States During Programming dialog box.
4. Sort the pins as desired by clicking any of the column headers to sort the entries by that header. Select the I/Os you wish to modify (Figure 1-7 on page 1-9).
5. Set the I/O Output State. You can set Basic I/O settings if you want to use the default I/O settings for your pins, or use Custom I/O settings to customize the settings for each pin. Basic I/O state settings:
 - 1 – I/O is set to drive out logic High
 - 0 – I/O is set to drive out logic Low
 - Last Known State – I/O is set to the last value that was driven out prior to entering the programming mode, and then held at that value during programming
 - Z -Tri-State: I/O is tristated

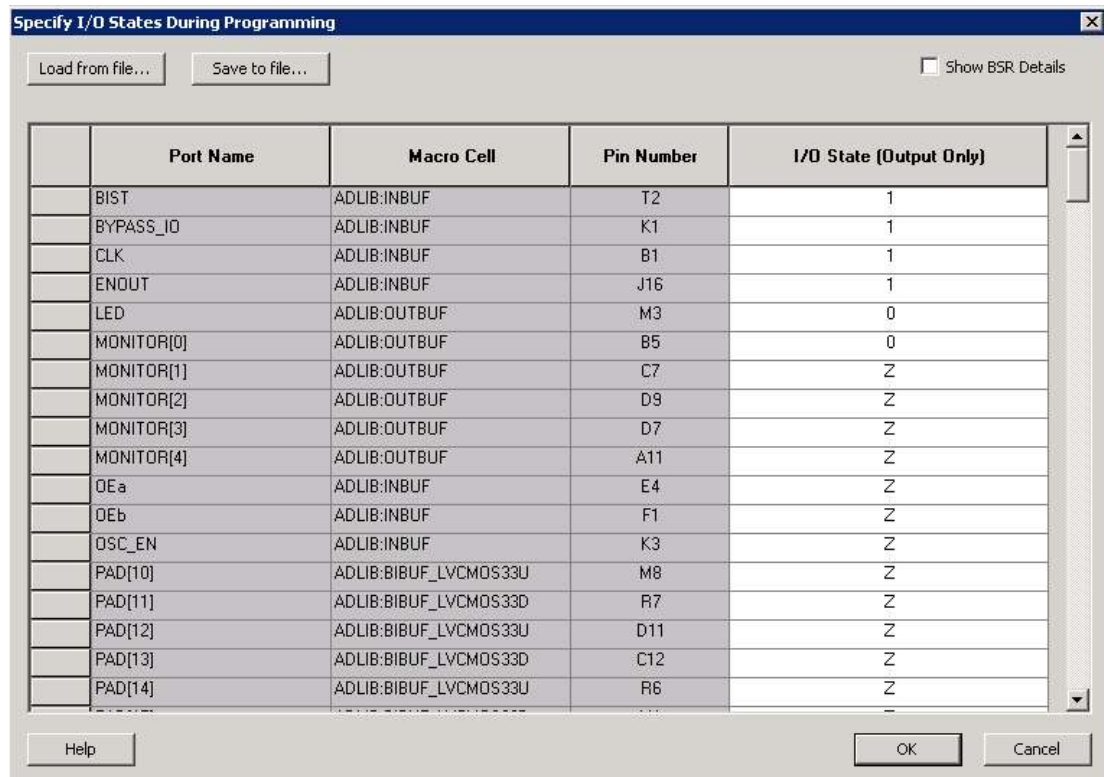

Figure 1-7 • I/O States During Programming Window

IGLOO nano Device Overview

6. Click **OK** to return to the FlashPoint – Programming File Generator window.

Note: I/O States During programming are saved to the ADB and resulting programming files after completing programming file generation.

2 – IGLOO nano DC and Switching Characteristics

General Specifications

The Z feature grade does not support the enhanced nano features of Schmitt trigger input, Flash*Freeze bus hold (hold previous I/O state in Flash*Freeze mode), cold-sparing, and hot-swap I/O capability. Refer to "IGLOO nano Ordering Information" on page IV for more information.

Operating Conditions

Stresses beyond those listed in Table 2-1 may cause permanent damage to the device.

Exposure to absolute maximum rating conditions for extended periods may affect device reliability. Absolute Maximum Ratings are stress ratings only; functional operation of the device at these or any other conditions beyond those listed under the Recommended Operating Conditions specified in Table 2-2 on page 2-2 is not implied.

Table 2-1 • Absolute Maximum Ratings

Symbol	Parameter	Limits	Units
VCC	DC core supply voltage	-0.3 to 1.65	V
VJTAG	JTAG DC voltage	-0.3 to 3.75	V
VPUMP	Programming voltage	-0.3 to 3.75	V
VCCPLL	Analog power supply (PLL)	-0.3 to 1.65	V
VCCI	DC I/O buffer supply voltage	-0.3 to 3.75	V
VI ¹	I/O input voltage	-0.3 V to 3.6 V	V
T _{STG} ²	Storage temperature	-65 to +150	°C
T _J ²	Junction temperature	+125	°C

Notes:

1. The device should be operated within the limits specified by the datasheet. During transitions, the input signal may undershoot or overshoot according to the limits shown in Table 2-4 on page 2-3.
2. For flash programming and retention maximum limits, refer to Table 2-3 on page 2-2, and for recommended operating limits, refer to Table 2-2 on page 2-2.

Table 2-2 • Recommended Operating Conditions ¹

Symbol	Parameter		Extended Commercial	Industrial	Units
T _J	Junction temperature		-20 to +85 ²	-40 to +100 ²	°C
VCC	1.5 V DC core supply voltage ³		1.425 to 1.575	1.425 to 1.575	V
	1.2 V–1.5 V wide range core voltage ^{4,5}		1.14 to 1.575	1.14 to 1.575	V
VJTAG	JTAG DC voltage		1.4 to 3.6	1.4 to 3.6	V
VPUMP ⁶	Programming voltage	Programming mode	3.15 to 3.45	3.15 to 3.45	V
		Operation	0 to 3.6	0 to 3.6	V
VCCPLL ⁷	Analog power supply (PLL)	1.5 V DC core supply voltage ³	1.425 to 1.575	1.425 to 1.575	V
		1.2 V–1.5 V wide range core supply voltage ⁴	1.14 to 1.575	1.14 to 1.575	V
VCCI and VMV ^{8,9}	1.2 V DC supply voltage ⁴		1.14 to 1.26	1.14 to 1.26	V
	1.2 V DC wide range supply voltage ⁴		1.14 to 1.575	1.14 to 1.575	V
	1.5 V DC supply voltage		1.425 to 1.575	1.425 to 1.575	V
	1.8 V DC supply voltage		1.7 to 1.9	1.7 to 1.9	V
	2.5 V DC supply voltage		2.3 to 2.7	2.3 to 2.7	V
	3.3 V DC supply voltage		3.0 to 3.6	3.0 to 3.6	V
	3.3 V DC wide range supply voltage ¹⁰		2.7 to 3.6	2.7 to 3.6	V

Notes:

- All parameters representing voltages are measured with respect to GND unless otherwise specified.
- Default Junction Temperature Range in the Libero SoC software is set to 0°C to +70°C for commercial, and -40°C to +85°C for industrial. To ensure targeted reliability standards are met across the full range of junction temperatures, Microsemi recommends using custom settings for temperature range before running timing and power analysis tools. For more information regarding custom settings, refer to the New Project Dialog Box in the Libero Online Help.
- For IGLOO[®] nano V5 devices
- For IGLOO nano V2 devices only, operating at VCCI ≥ VCC
- IGLOO nano V5 devices can be programmed with the VCC core voltage at 1.5 V only. IGLOO nano V2 devices can be programmed with the VCC core voltage at 1.2 V (with FlashPro4 only) or 1.5 V. If you are using FlashPro3 and want to do in-system programming using 1.2 V, please contact the factory.
- V_{PUMP} can be left floating during operation (not programming mode).
- VCCPLL pins should be tied to VCC pins. See the "Pin Descriptions" chapter for further information.
- VMV pins must be connected to the corresponding VCCI pins. See the Pin Descriptions chapter of the IGLOO nano FPGA Fabric User's Guide for further information.
- The ranges given here are for power supplies only. The recommended input voltage ranges specific to each I/O standard are given in Table 2-21 on page 2-19. VCCI should be at the same voltage within a given I/O bank.
- 3.3 V wide range is compliant to the JESD8-B specification and supports 3.0 V VCCI operation.

Table 2-3 • Flash Programming Limits – Retention, Storage, and Operating Temperature¹

Product Grade	Programming Cycles	Program Retention (biased/unbiased)	Maximum Storage Temperature T _{STG} (°C) ²	Maximum Operating Junction Temperature T _J (°C) ²
Commercial	500	20 years	110	100
Industrial	500	20 years	110	100

Notes:

- This is a stress rating only; functional operation at any condition other than those indicated is not implied.
- These limits apply for program/data retention only. Refer to Table 2-1 on page 2-1 and Table 2-2 for device operating conditions and absolute limits.

Table 2-4 • Overshoot and Undershoot Limits¹

VCCI	Average VCCI–GND Overshoot or Undershoot Duration as a Percentage of Clock Cycle ²	Maximum Overshoot/Undershoot ²
2.7 V or less	10%	1.4 V
	5%	1.49 V
3 V	10%	1.1 V
	5%	1.19 V
3.3 V	10%	0.79 V
	5%	0.88 V
3.6 V	10%	0.45 V
	5%	0.54 V

Notes:

1. Based on reliability requirements at 85°C.
2. The duration is allowed at one out of six clock cycles. If the overshoot/undershoot occurs at one out of two cycles, the maximum overshoot/undershoot has to be reduced by 0.15 V.

I/O Power-Up and Supply Voltage Thresholds for Power-On Reset (Commercial and Industrial)

Sophisticated power-up management circuitry is designed into every IGLOO nano device. These circuits ensure easy transition from the powered-off state to the powered-up state of the device. The many different supplies can power up in any sequence with minimized current spikes or surges. In addition, the I/O will be in a known state through the power-up sequence. The basic principle is shown in [Figure 2-1 on page 2-4](#).

There are five regions to consider during power-up.

IGLOO nano I/Os are activated only if ALL of the following three conditions are met:

1. VCC and VCCI are above the minimum specified trip points ([Figure 2-1](#) and [Figure 2-2 on page 2-5](#)).
2. $VCCI > VCC - 0.75 \text{ V}$ (typical)
3. Chip is in the operating mode.

VCCI Trip Point:

Ramping up (V5 devices): $0.6 \text{ V} < \text{trip_point_up} < 1.2 \text{ V}$

Ramping down (V5 devices): $0.5 \text{ V} < \text{trip_point_down} < 1.1 \text{ V}$

Ramping up (V2 devices): $0.75 \text{ V} < \text{trip_point_up} < 1.05 \text{ V}$

Ramping down (V2 devices): $0.65 \text{ V} < \text{trip_point_down} < 0.95 \text{ V}$

VCC Trip Point:

Ramping up (V5 devices): $0.6 \text{ V} < \text{trip_point_up} < 1.1 \text{ V}$

Ramping down (V5 devices): $0.5 \text{ V} < \text{trip_point_down} < 1.0 \text{ V}$

Ramping up (V2 devices): $0.65 \text{ V} < \text{trip_point_up} < 1.05 \text{ V}$

Ramping down (V2 devices): $0.55 \text{ V} < \text{trip_point_down} < 0.95 \text{ V}$

VCC and VCCI ramp-up trip points are about 100 mV higher than ramp-down trip points. This specifically built-in hysteresis prevents undesirable power-up oscillations and current surges. Note the following:

- During programming, I/Os become tristated and weakly pulled up to VCCI.
- JTAG supply, PLL power supplies, and charge pump VPUMP supply have no influence on I/O behavior.

PLL Behavior at Brownout Condition

Microsemi recommends using monotonic power supplies or voltage regulators to ensure proper power-up behavior. Power ramp-up should be monotonic at least until VCC and VCCPLX exceed brownout activation levels (see Figure 2-1 and Figure 2-2 on page 2-5 for more details).

When PLL power supply voltage and/or VCC levels drop below the VCC brownout levels ($0.75\text{ V} \pm 0.25\text{ V}$ for V5 devices, and $0.75\text{ V} \pm 0.2\text{ V}$ for V2 devices), the PLL output lock signal goes LOW and/or the output clock is lost. Refer to the "Brownout Voltage" section in the "Power-Up/Down Behavior of Low Power Flash Devices" chapter of the *IGLOO nano FPGA Fabric User's Guide* for information on clock and lock recovery.

Internal Power-Up Activation Sequence

1. Core
2. Input buffers
3. Output buffers, after 200 ns delay from input buffer activation

To make sure the transition from input buffers to output buffers is clean, ensure that there is no path longer than 100 ns from input buffer to output buffer in your design.

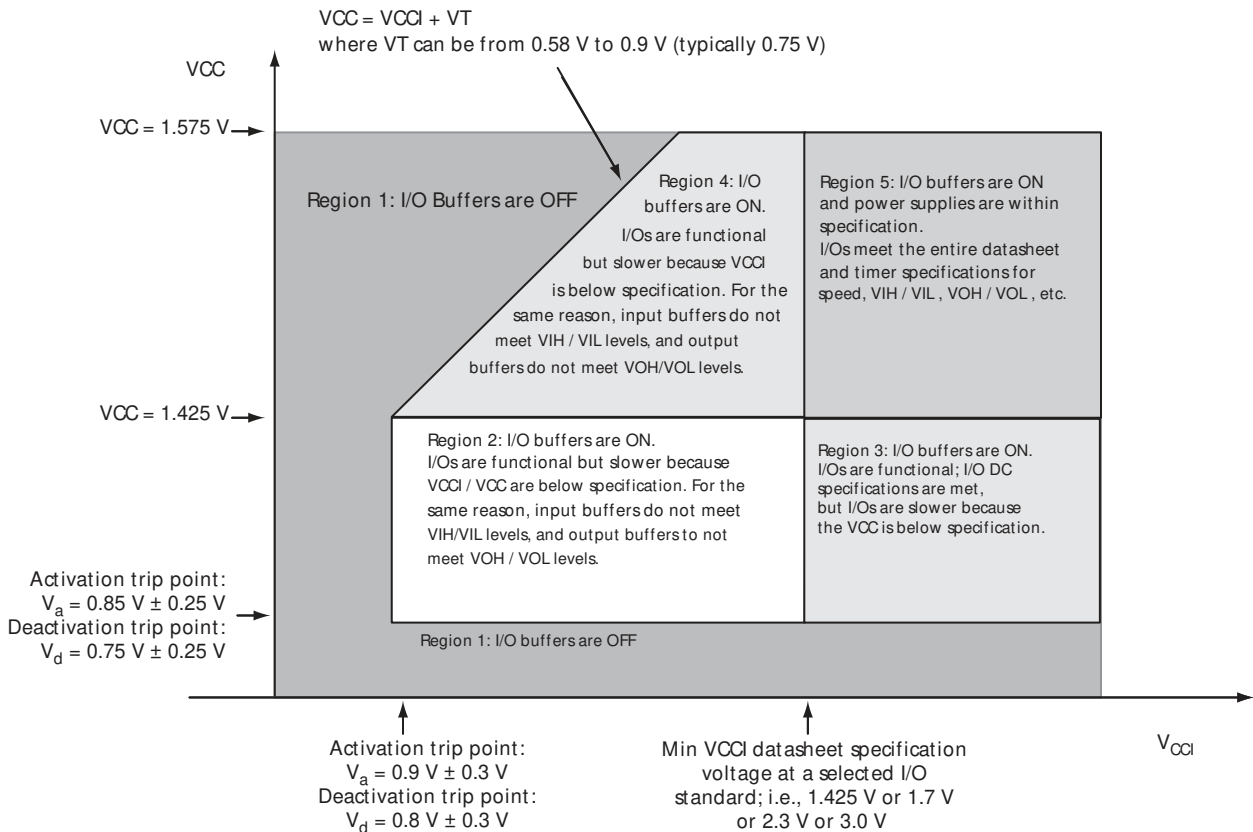

Figure 2-1 • V5 Devices – I/O State as a Function of VCCI and VCC Voltage Levels

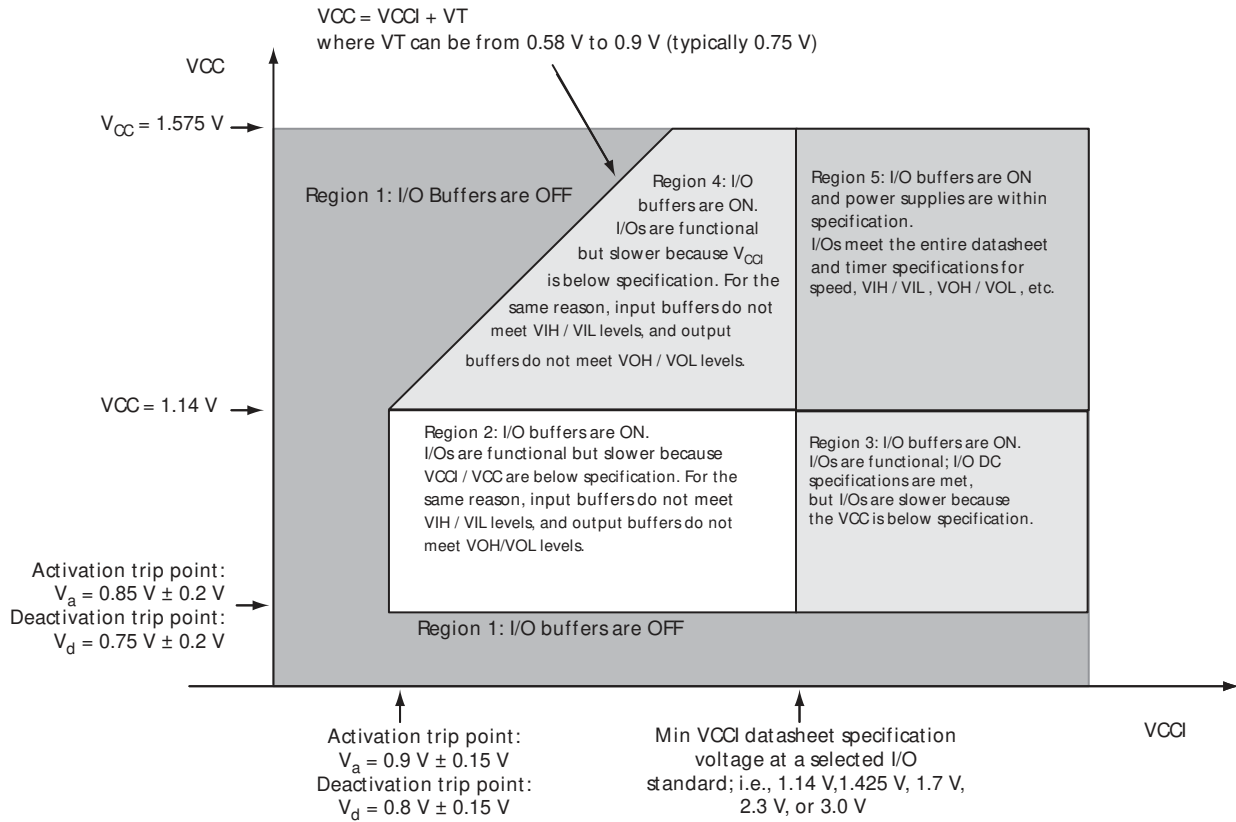

Figure 2-2 • V2 Devices – I/O State as a Function of VCCI and VCC Voltage Levels

Thermal Characteristics

Introduction

The temperature variable in the Microsemi Designer software refers to the junction temperature, not the ambient temperature. This is an important distinction because dynamic and static power consumption cause the chip junction temperature to be higher than the ambient temperature.

EQ 1 can be used to calculate junction temperature.

$$T_J = \text{Junction Temperature} = \Delta T + T_A$$

EQ 1

where:

T_A = Ambient temperature

ΔT = Temperature gradient between junction (silicon) and ambient $\Delta T = \theta_{ja} * P$

θ_{ja} = Junction-to-ambient of the package. θ_{ja} numbers are located in Figure 2-5.

P = Power dissipation

Package Thermal Characteristics

The device junction-to-case thermal resistivity is θ_{jc} and the junction-to-ambient air thermal resistivity is θ_{ja} . The thermal characteristics for θ_{ja} are shown for two air flow rates. The maximum operating junction temperature is 100°C. EQ 2 shows a sample calculation of the maximum operating power dissipation allowed for a 484-pin FBGA package at commercial temperature and in still air.

$$\text{Maximum Power Allowed} = \frac{\text{Max. junction temp. (}^\circ\text{C)} - \text{Max. ambient temp. (}^\circ\text{C)}}{\theta_{ja}(\text{}^\circ\text{C/W)}} = \frac{100^\circ\text{C} - 70^\circ\text{C}}{20.5^\circ\text{C/W}} = 1.46 \text{ W}$$

EQ 2

Table 2-5 • Package Thermal Resistivities

Package Type	Pin Count	θ_{jc}	θ_{ja}			Units
			Still Air	200 ft./min.	500 ft./min.	
Chip Scale Package (CSP)	36	TBD	TBD	TBD	TBD	C/W
	81	TBD	TBD	TBD	TBD	C/W
Quad Flat No Lead (QFN)	48	TBD	TBD	TBD	TBD	C/W
	68	TBD	TBD	TBD	TBD	C/W
	100	TBD	TBD	TBD	TBD	C/W
Very Thin Quad Flat Pack (VQFP)	100	10.0	35.3	29.4	27.1	C/W

Temperature and Voltage Derating Factors

Table 2-6 • Temperature and Voltage Derating Factors for Timing Delays (normalized to $T_J = 70^\circ\text{C}$, $V_{CC} = 1.425 \text{ V}$)
For IGLOO nano V2 or V5 Devices, 1.5 V DC Core Supply Voltage

Array Voltage V_{CC} (V)	Junction Temperature ($^\circ\text{C}$)						
	-40°C	-20°C	0°C	25°C	70°C	85°C	100°C
1.425	0.947	0.956	0.965	0.978	1.000	1.009	1.013
1.5	0.875	0.883	0.892	0.904	0.925	0.932	0.937
1.575	0.821	0.829	0.837	0.848	0.868	0.875	0.879

**Table 2-7 • Temperature and Voltage Derating Factors for Timing Delays (normalized to $T_J = 70^\circ\text{C}$, $V_{CC} = 1.14\text{ V}$)
For IGLOO nano V2, 1.2 V DC Core Supply Voltage**

Array Voltage VCC (V)	Junction Temperature ($^\circ\text{C}$)						
	-40°C	-20°C	0°C	25°C	70°C	85°C	100°C
1.14	0.968	0.974	0.979	0.991	1.000	1.006	1.009
1.2	0.863	0.868	0.873	0.884	0.892	0.898	0.901
1.26	0.792	0.797	0.801	0.811	0.819	0.824	0.827

Calculating Power Dissipation

Quiescent Supply Current

Quiescent supply current (I_{DD}) calculation depends on multiple factors, including operating voltages (V_{CC} , V_{CCI} , and V_{JTAG}), operating temperature, system clock frequency, and power mode usage. Microsemi recommends using the Power Calculator and SmartPower software estimation tools to evaluate the projected static and active power based on the user design, power mode usage, operating voltage, and temperature.

Table 2-8 • Power Supply State per Mode

Modes/Power Supplies	Power Supply Configurations				
	VCC	VCCPLL	VCCI	VJTAG	VPUMP
Flash*Freeze	On	On	On	On	On/off/floating
Sleep	Off	Off	On	Off	Off
Shutdown	Off	Off	Off	Off	Off
No Flash*Freeze	On	On	On	On	On/off/floating

Note: Off: Power Supply level = 0 V

Table 2-9 • Quiescent Supply Current (I_{DD}) Characteristics, IGLOO nano Flash*Freeze Mode*

	Core Voltage	AGLN010	AGLN020	AGLN060	AGLN125	AGLN250	Units
Typical (25°C)	1.2 V	1.9	3.3	8	13	20	μA
	1.5 V	5.8	6	10	18	34	μA

Note: * I_{DD} includes V_{CC} , $VPUMP$, $VCCI$, $VCCPLL$, and VMV currents. Values do not include I/O static contribution, which is shown in Table 2-13 on page 2-9 through Table 2-14 on page 2-9 and Table 2-15 on page 2-10 through Table 2-18 on page 2-11 (PDC6 and PDC7).

Table 2-10 • Quiescent Supply Current (IDD) Characteristics, IGLOO nano Sleep Mode*

	Core Voltage	AGLN010	AGLN020	AGLN060	AGLN125	AGLN250	Units
VCCI = 1.2 V (per bank) Typical (25°C)	1.2 V	1.7	1.7	1.7	1.7	1.7	μA
VCCI = 1.5 V (per bank) Typical (25°C)	1.2 V / 1.5 V	1.8	1.8	1.8	1.8	1.8	μA
VCCI = 1.8 V (per bank) Typical (25°C)	1.2 V / 1.5 V	1.9	1.9	1.9	1.9	1.9	μA
VCCI = 2.5 V (per bank) Typical (25°C)	1.2 V / 1.5 V	2.2	2.2	2.2	2.2	2.2	μA
VCCI = 3.3 V (per bank) Typical (25°C)	1.2 V / 1.5 V	2.5	2.5	2.5	2.5	2.5	μA

Note: $*I_{DD} = N_{BANKS} * I_{CCI}$

Table 2-11 • Quiescent Supply Current (IDD) Characteristics, IGLOO nano Shutdown Mode

	Core Voltage	AGLN010	AGLN020	AGLN060	AGLN125	AGLN250	Units
Typical (25°C)	1.2 V / 1.5 V	0	0	0	0	0	μA

Table 2-12 • Quiescent Supply Current (IDD), No IGLOO nano Flash*Freeze Mode¹

	Core Voltage	AGLN010	AGLN020	AGLN060	AGLN125	AGLN250	Units
ICCA Current²							
Typical (25°C)	1.2 V	3.7	5	10	13	18	μA
	1.5 V	8	14	20	28	44	μA
ICCI or IJTAG Current							
VCCI / VJTAG = 1.2 V (per bank) Typical (25°C)	1.2 V	1.7	1.7	1.7	1.7	1.7	μA
VCCI / VJTAG = 1.5 V (per bank) Typical (25°C)	1.2 V / 1.5 V	1.8	1.8	1.8	1.8	1.8	μA
VCCI / VJTAG = 1.8 V (per bank) Typical (25°C)	1.2 V / 1.5 V	1.9	1.9	1.9	1.9	1.9	μA
VCCI / VJTAG = 2.5 V (per bank) Typical (25°C)	1.2 V / 1.5 V	2.2	2.2	2.2	2.2	2.2	μA
VCCI / VJTAG = 3.3 V (per bank) Typical (25°C)	1.2 V / 1.5 V	2.5	2.5	2.5	2.5	2.5	μA

Notes:

1. $IDD = N_{BANKS} * ICCI + ICCA$. JTAG counts as one bank when powered.
2. Includes VCC, VCCPLL, and VPUMP currents.

Power per I/O Pin

Table 2-13 • Summary of I/O Input Buffer Power (per pin) – Default I/O Software Settings
Applicable to IGLOO nano I/O Banks

	VCCI (V)	Dynamic Power PAC9 (μW/MHz) ¹
Single-Ended		
3.3 V LVTTTL / 3.3 V LVCMOS	3.3	16.38
3.3 V LVTTTL / 3.3 V LVCMOS – Schmitt Trigger	3.3	18.89
3.3 V LVCMOS Wide Range ²	3.3	16.38
3.3 V LVCMOS Wide Range – Schmitt Trigger	3.3	18.89
2.5 V LVCMOS	2.5	4.71
2.5 V LVCMOS – Schmitt Trigger	2.5	6.13
1.8 V LVCMOS	1.8	1.64
1.8 V LVCMOS – Schmitt Trigger	1.8	1.79
1.5 V LVCMOS (JESD8-11)	1.5	0.97
1.5 V LVCMOS (JESD8-11) – Schmitt Trigger	1.5	0.96
1.2 V LVCMOS ³	1.2	0.57
1.2 V LVCMOS – Schmitt Trigger ³	1.2	0.52
1.2 V LVCMOS Wide Range ³	1.2	0.57
1.2 V LVCMOS Wide Range – Schmitt Trigger ³	1.2	0.52

Notes:

1. PAC9 is the total dynamic power measured on V_{CCI}.
2. All LVCMOS 3.3 V software macros support LVCMOS 3.3 V wide range as specified in the JESD8-B specification.
3. Applicable to IGLOO nano V2 devices operating at VCCI ≥ VCC.

Table 2-14 • Summary of I/O Output Buffer Power (per pin) – Default I/O Software Settings¹
Applicable to IGLOO nano I/O Banks

	C _{LOAD} (pF)	VCCI (V)	Dynamic Power PAC10 (μW/MHz) ²
Single-Ended			
3.3 V LVTTTL / 3.3 V LVCMOS	5	3.3	107.98
3.3 V LVCMOS Wide Range ³	5	3.3	107.98
2.5 V LVCMOS	5	2.5	61.24
1.8 V LVCMOS	5	1.8	31.28
1.5 V LVCMOS (JESD8-11)	5	1.5	21.50
1.2 V LVCMOS ⁴	5	1.2	15.22

Notes:

1. Dynamic power consumption is given for standard load and software default drive strength and output slew.
2. PAC10 is the total dynamic power measured on VCCI.
3. All LVCMOS 3.3 V software macros support LVCMOS 3.3 V wide range as specified in the JESD8-B specification.
4. Applicable for IGLOO nano V2 devices operating at VCCI ≥ VCC.

Power Consumption of Various Internal Resources

Table 2-15 • Different Components Contributing to Dynamic Power Consumption in IGLOO nano Devices
For IGLOO nano V2 or V5 Devices, 1.5 V Core Supply Voltage

Parameter	Definition	Device Specific Dynamic Power ($\mu\text{W}/\text{MHz}$)				
		AGLN250	AGLN125	AGLN060	AGLN020	AGLN010
PAC1	Clock contribution of a Global Rib	4.421	4.493	2.700	0	0
PAC2	Clock contribution of a Global Spine	2.704	1.976	1.982	4.002	2.633
PAC3	Clock contribution of a VersaTile row	1.496	1.504	1.511	1.346	1.340
PAC4	Clock contribution of a VersaTile used as a sequential module	0.152	0.153	0.153	0.148	0.143
PAC5	First contribution of a VersaTile used as a sequential module	0.057				
PAC6	Second contribution of a VersaTile used as a sequential module	0.207				
PAC7	Contribution of a VersaTile used as a combinatorial module	0.17				
PAC8	Average contribution of a routing net	0.7				
PAC9	Contribution of an I/O input pin (standard-dependent)	See Table 2-13 on page 2-9.				
PAC10	Contribution of an I/O output pin (standard-dependent)	See Table 2-14.				
PAC11	Average contribution of a RAM block during a read operation	25.00			N/A	
PAC12	Average contribution of a RAM block during a write operation	30.00			N/A	
PAC13	Dynamic contribution for PLL	2.70			N/A	

Table 2-16 • Different Components Contributing to the Static Power Consumption in IGLOO nano Devices
For IGLOO nano V2 or V5 Devices, 1.5 V Core Supply Voltage

Parameter	Definition	Device -Specific Static Power (mW)				
		AGLN250	AGLN125	AGLN060	AGLN020	AGLN010
PDC1	Array static power in Active mode	See Table 2-12 on page 2-8				
PDC2	Array static power in Static (Idle) mode	See Table 2-12 on page 2-8				
PDC3	Array static power in Flash*Freeze mode	See Table 2-9 on page 2-7				
PDC4 ¹	Static PLL contribution	1.84			N/A	
PDC5	Bank quiescent power (VCCI-dependent) ²	See Table 2-12 on page 2-8				

Notes:

1. Minimum contribution of the PLL when running at lowest frequency.
2. For a different output load, drive strength, or slew rate, Microsemi recommends using the Microsemi power spreadsheet calculator or the SmartPower tool in Libero SoC.

Table 2-17 • Different Components Contributing to Dynamic Power Consumption in IGLOO nano Devices For IGLOO nano V2 Devices, 1.2 V Core Supply Voltage

Parameter	Definition	Device-Specific Dynamic Power ($\mu\text{W}/\text{MHz}$)					
		AGLN250	AGLN125	AGLN060	AGLN020	AGLN015	AGLN010
PAC1	Clock contribution of a Global Rib	2.829	2.875	1.728	0	0	0
PAC2	Clock contribution of a Global Spine	1.731	1.265	1.268	2.562	2.562	1.685
PAC3	Clock contribution of a VersaTile row	0.957	0.963	0.967	0.862	0.862	0.858
PAC4	Clock contribution of a VersaTile used as a sequential module	0.098	0.098	0.098	0.094	0.094	0.091
PAC5	First contribution of a VersaTile used as a sequential module	0.045					
PAC6	Second contribution of a VersaTile used as a sequential module	0.186					
PAC7	Contribution of a VersaTile used as a combinatorial module	0.11					
PAC8	Average contribution of a routing net	0.45					
PAC9	Contribution of an I/O input pin (standard-dependent)	See Table 2-13 on page 2-9					
PAC10	Contribution of an I/O output pin (standard-dependent)	See Table 2-14 on page 2-9					
PAC11	Average contribution of a RAM block during a read operation	25.00			N/A		
PAC12	Average contribution of a RAM block during a write operation	30.00			N/A		
PAC13	Dynamic contribution for PLL	2.10			N/A		

Table 2-18 • Different Components Contributing to the Static Power Consumption in IGLOO nano Devices For IGLOO nano V2 Devices, 1.2 V Core Supply Voltage

Parameter	Definition	Device-Specific Static Power (mW)					
		AGLN250	AGLN125	AGLN060	AGLN020	AGLN015	AGLN010
PDC1	Array static power in Active mode	See Table 2-12 on page 2-8					
PDC2	Array static power in Static (Idle) mode	See Table 2-12 on page 2-8					
PDC3	Array static power in Flash*Freeze mode	See Table 2-9 on page 2-7					
PDC4 ¹	Static PLL contribution	0.90			N/A		
PDC5	Bank quiescent power (VCCI-dependent) ²	See Table 2-12 on page 2-8					

Notes:

1. Minimum contribution of the PLL when running at lowest frequency.
2. For a different output load, drive strength, or slew rate, Microsemi recommends using the Microsemi power spreadsheet calculator or the SmartPower tool in Libero SoC.

Power Calculation Methodology

This section describes a simplified method to estimate power consumption of an application. For more accurate and detailed power estimations, use the SmartPower tool in Libero SoC software.

The power calculation methodology described below uses the following variables:

- The number of PLLs as well as the number and the frequency of each output clock generated
- The number of combinatorial and sequential cells used in the design
- The internal clock frequencies
- The number and the standard of I/O pins used in the design
- The number of RAM blocks used in the design
- Toggle rates of I/O pins as well as VersaTiles—guidelines are provided in [Table 2-19 on page 2-14](#).
- Enable rates of output buffers—guidelines are provided for typical applications in [Table 2-20 on page 2-14](#).
- Read rate and write rate to the memory—guidelines are provided for typical applications in [Table 2-20 on page 2-14](#). The calculation should be repeated for each clock domain defined in the design.

Methodology

Total Power Consumption— P_{TOTAL}

$$P_{TOTAL} = P_{STAT} + P_{DYN}$$

P_{STAT} is the total static power consumption.

P_{DYN} is the total dynamic power consumption.

Total Static Power Consumption— P_{STAT}

$$P_{STAT} = (PDC1 \text{ or } PDC2 \text{ or } PDC3) + N_{BANKS} * PDC5$$

N_{BANKS} is the number of I/O banks powered in the design.

Total Dynamic Power Consumption— P_{DYN}

$$P_{DYN} = P_{CLOCK} + P_{S-CELL} + P_{C-CELL} + P_{NET} + P_{INPUTS} + P_{OUTPUTS} + P_{MEMORY} + P_{PLL}$$

Global Clock Contribution— P_{CLOCK}

$$P_{CLOCK} = (PAC1 + N_{SPINE} * PAC2 + N_{ROW} * PAC3 + N_{S-CELL} * PAC4) * F_{CLK}$$

N_{SPINE} is the number of global spines used in the user design—guidelines are provided in the "Spine Architecture" section of the [IGLOO nano FPGA Fabric User's Guide](#).

N_{ROW} is the number of VersaTile rows used in the design—guidelines are provided in the "Spine Architecture" section of the [IGLOO nano FPGA Fabric User's Guide](#).

F_{CLK} is the global clock signal frequency.

N_{S-CELL} is the number of VersaTiles used as sequential modules in the design.

PAC1, PAC2, PAC3, and PAC4 are device-dependent.

Sequential Cells Contribution— P_{S-CELL}

$$P_{S-CELL} = N_{S-CELL} * (PAC5 + \alpha_1 / 2 * PAC6) * F_{CLK}$$

N_{S-CELL} is the number of VersaTiles used as sequential modules in the design. When a multi-tile sequential cell is used, it should be accounted for as 1.

α_1 is the toggle rate of VersaTile outputs—guidelines are provided in [Table 2-19 on page 2-14](#).

F_{CLK} is the global clock signal frequency.

Combinatorial Cells Contribution— P_{C-CELL}

$$P_{C-CELL} = N_{C-CELL} * \alpha_1 / 2 * PAC7 * F_{CLK}$$

N_{C-CELL} is the number of VersaTiles used as combinatorial modules in the design.

α_1 is the toggle rate of VersaTile outputs—guidelines are provided in [Table 2-19](#) on page 2-14.

F_{CLK} is the global clock signal frequency.

Routing Net Contribution— P_{NET}

$$P_{NET} = (N_{S-CELL} + N_{C-CELL}) * \alpha_1 / 2 * PAC8 * F_{CLK}$$

N_{S-CELL} is the number of VersaTiles used as sequential modules in the design.

N_{C-CELL} is the number of VersaTiles used as combinatorial modules in the design.

α_1 is the toggle rate of VersaTile outputs—guidelines are provided in [Table 2-19](#) on page 2-14.

F_{CLK} is the global clock signal frequency.

I/O Input Buffer Contribution— P_{INPUTS}

$$P_{INPUTS} = N_{INPUTS} * \alpha_2 / 2 * PAC9 * F_{CLK}$$

N_{INPUTS} is the number of I/O input buffers used in the design.

α_2 is the I/O buffer toggle rate—guidelines are provided in [Table 2-19](#) on page 2-14.

F_{CLK} is the global clock signal frequency.

I/O Output Buffer Contribution— $P_{OUTPUTS}$

$$P_{OUTPUTS} = N_{OUTPUTS} * \alpha_2 / 2 * \beta_1 * PAC10 * F_{CLK}$$

$N_{OUTPUTS}$ is the number of I/O output buffers used in the design.

α_2 is the I/O buffer toggle rate—guidelines are provided in [Table 2-19](#) on page 2-14.

β_1 is the I/O buffer enable rate—guidelines are provided in [Table 2-20](#) on page 2-14.

F_{CLK} is the global clock signal frequency.

RAM Contribution— P_{MEMORY}

$$P_{MEMORY} = PAC11 * N_{BLOCKS} * F_{READ-CLOCK} * \beta_2 + PAC12 * N_{BLOCK} * F_{WRITE-CLOCK} * \beta_3$$

N_{BLOCKS} is the number of RAM blocks used in the design.

$F_{READ-CLOCK}$ is the memory read clock frequency.

β_2 is the RAM enable rate for read operations.

$F_{WRITE-CLOCK}$ is the memory write clock frequency.

β_3 is the RAM enable rate for write operations—guidelines are provided in [Table 2-20](#) on page 2-14.

PLL Contribution— P_{PLL}

$$P_{PLL} = PDC4 + PAC13 * F_{CLKOUT}$$

F_{CLKOUT} is the output clock frequency.¹

1. If a PLL is used to generate more than one output clock, include each output clock in the formula by adding its corresponding contribution ($PAC13 * F_{CLKOUT}$ product) to the total PLL contribution.

Guidelines

Toggle Rate Definition

A toggle rate defines the frequency of a net or logic element relative to a clock. It is a percentage. If the toggle rate of a net is 100%, this means that this net switches at half the clock frequency. Below are some examples:

- The average toggle rate of a shift register is 100% because all flip-flop outputs toggle at half of the clock frequency.
- The average toggle rate of an 8-bit counter is 25%:
 - Bit 0 (LSB) = 100%
 - Bit 1 = 50%
 - Bit 2 = 25%
 - ...
 - Bit 7 (MSB) = 0.78125%
 - Average toggle rate = $(100\% + 50\% + 25\% + 12.5\% + \dots + 0.78125\%) / 8$

Enable Rate Definition

Output enable rate is the average percentage of time during which tristate outputs are enabled. When nontristate output buffers are used, the enable rate should be 100%.

Table 2-19 • Toggle Rate Guidelines Recommended for Power Calculation

Component	Definition	Guideline
α_1	Toggle rate of VersaTile outputs	10%
α_2	I/O buffer toggle rate	10%

Table 2-20 • Enable Rate Guidelines Recommended for Power Calculation

Component	Definition	Guideline
β_1	I/O output buffer enable rate	100%
β_2	RAM enable rate for read operations	12.5%
β_3	RAM enable rate for write operations	12.5%

User I/O Characteristics

Timing Model

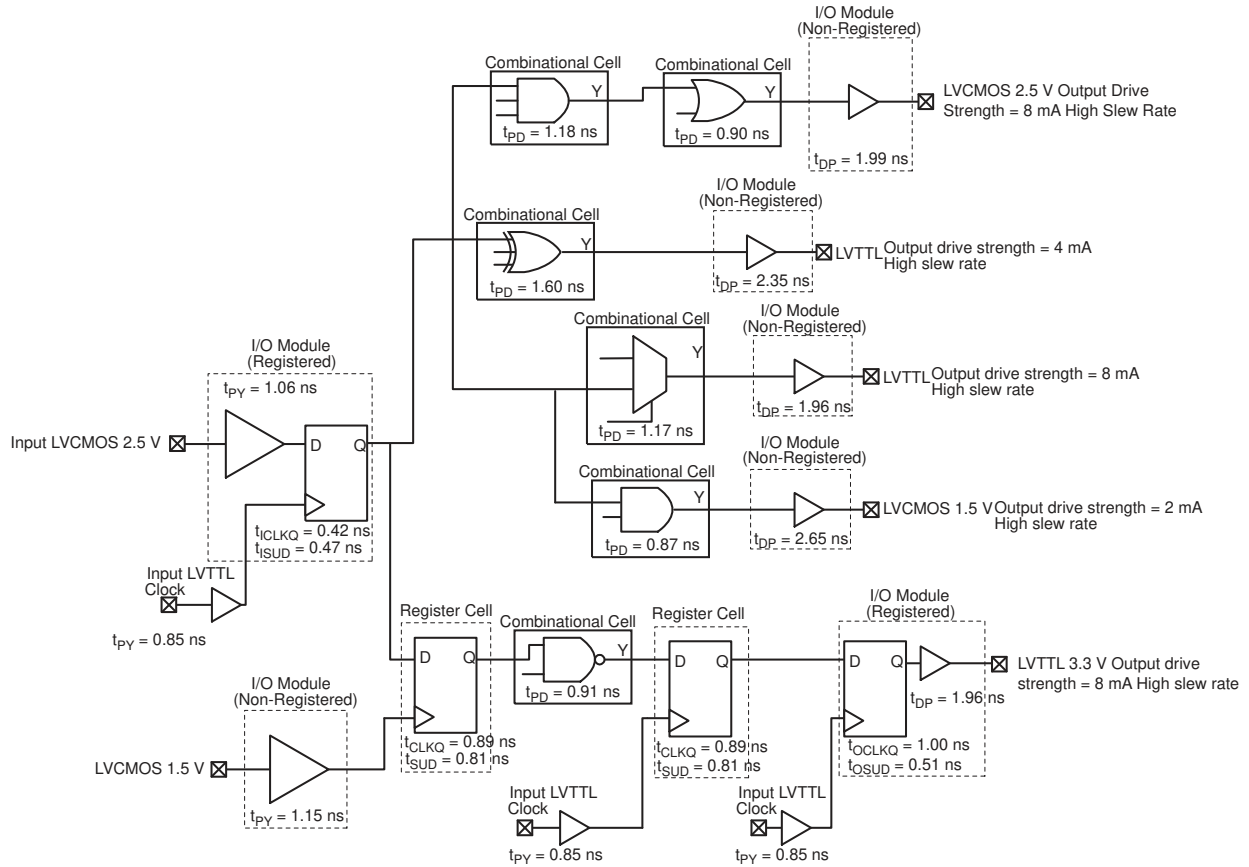

Figure 2-3 • Timing Model
Operating Conditions: STD Speed, Commercial Temperature Range ($T_J = 70^\circ\text{C}$), Worst-Case $V_{CC} = 1.425$ V, for DC 1.5 V Core Voltage, Applicable to V2 and V5 Devices

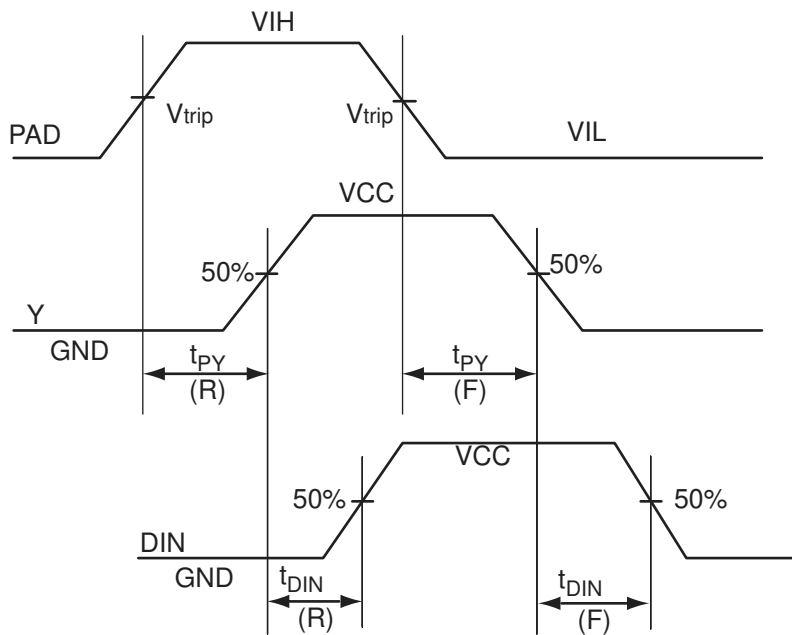
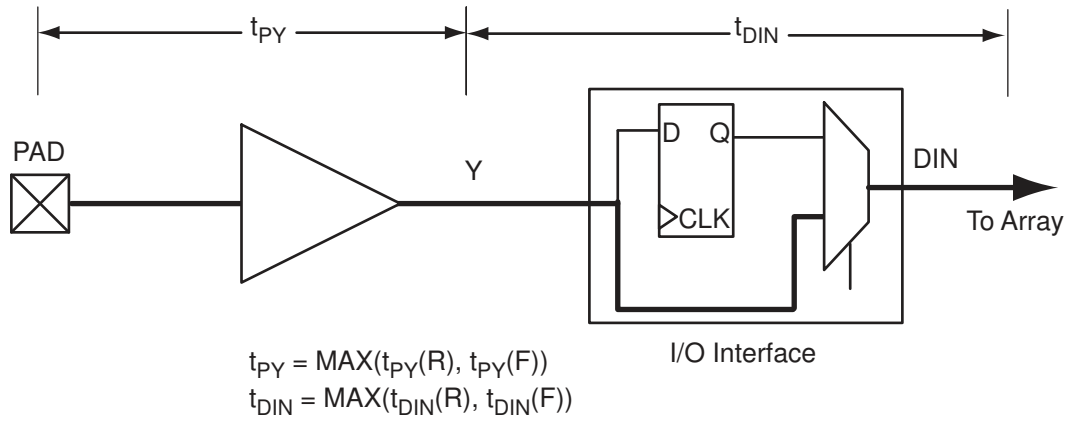

Figure 2-4 • Input Buffer Timing Model and Delays (example)

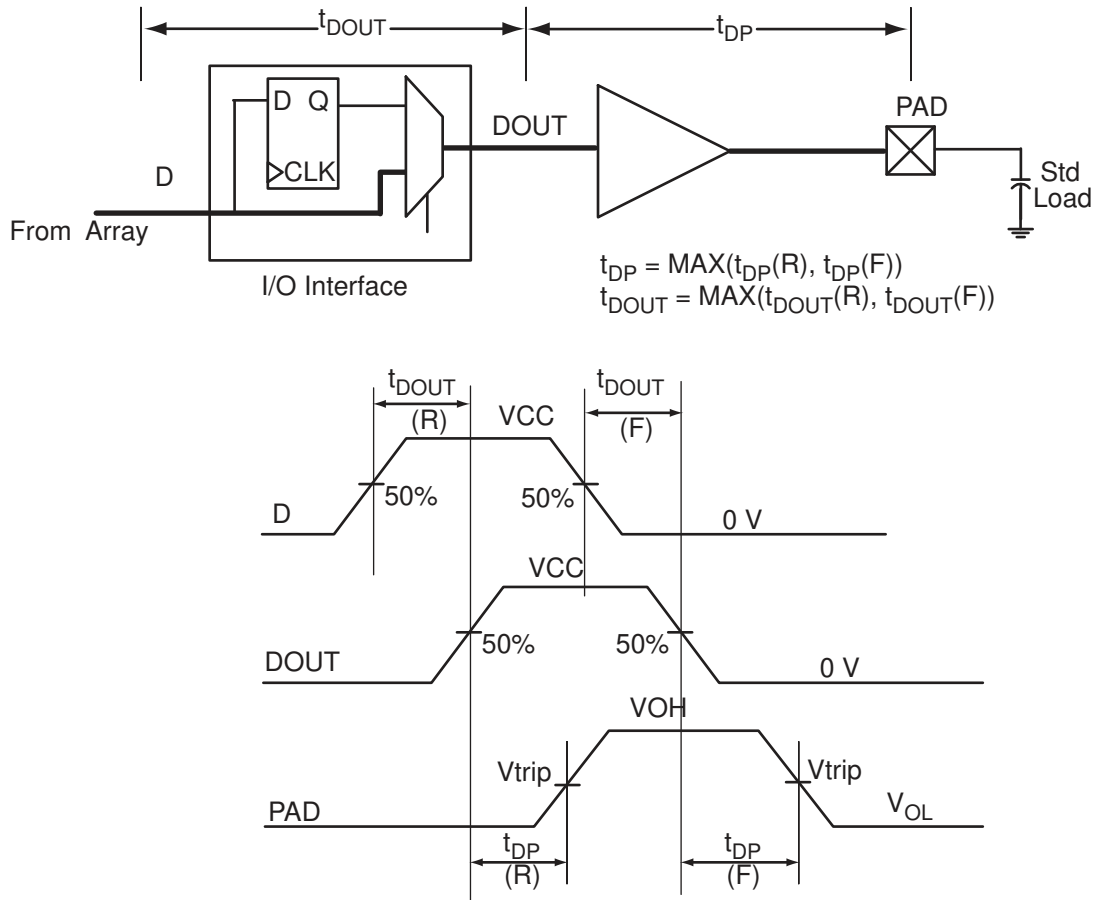

Figure 2-5 • Output Buffer Model and Delays (example)

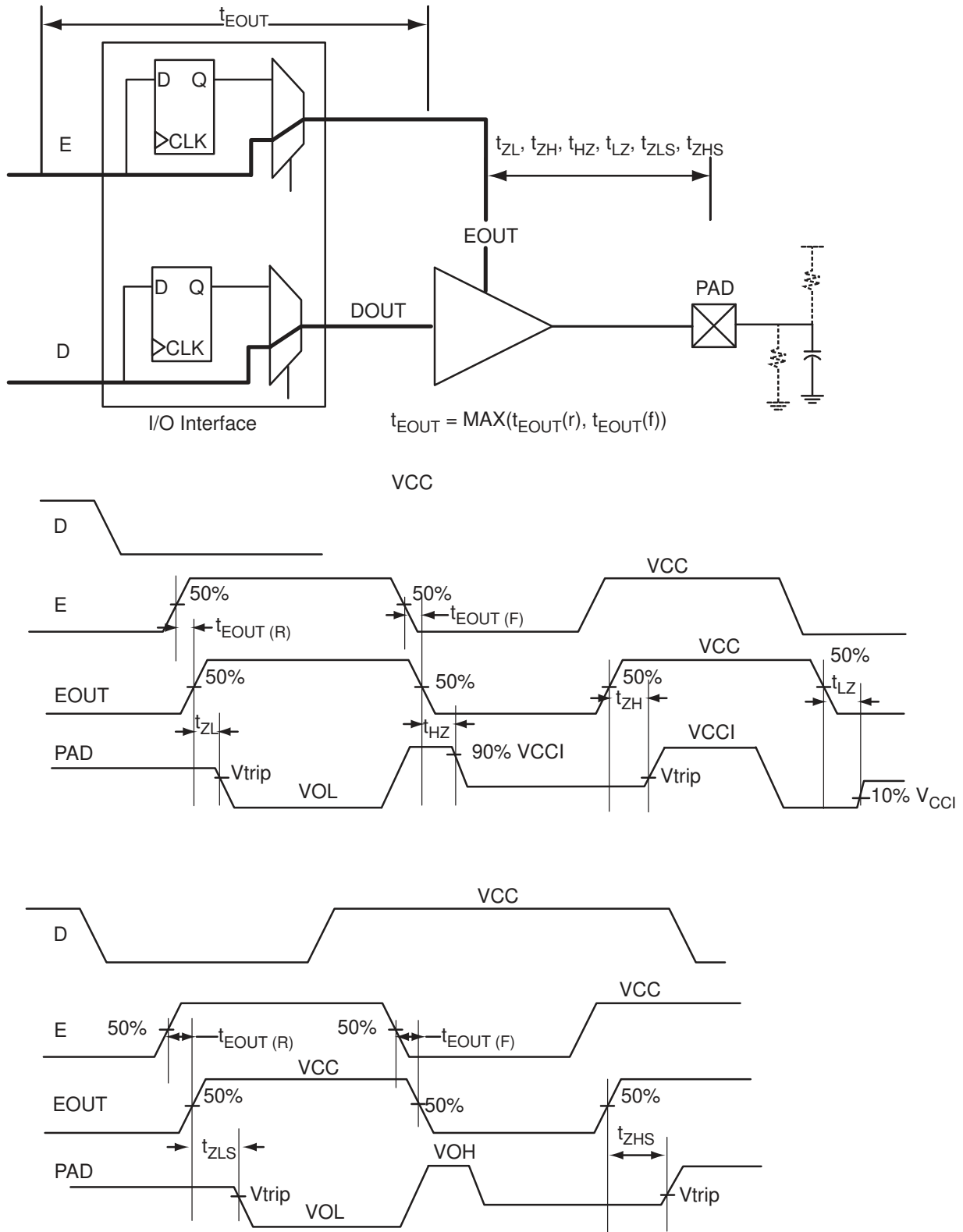

Figure 2-6 • Tristate Output Buffer Timing Model and Delays (example)

Overview of I/O Performance

Summary of I/O DC Input and Output Levels – Default I/O Software Settings

**Table 2-21 • Summary of Maximum and Minimum DC Input and Output Levels
Applicable to Commercial and Industrial Conditions—Software Default Settings**

I/O Standard	Drive Strength	Equivalent Software Default Drive Strength ²	Slew Rate	VIL		VIH		VOL	VOH	IOL ¹	IOH ¹
				Min. V	Max. V	Min. V	Max. V	Max. V	Min. V	mA	mA
3.3 V LVTTTL / 3.3 V LVCMOS	8 mA	8 mA	High	-0.3	0.8	2	3.6	0.4	2.4	8	8
3.3 V LVCMOS Wide Range ³	100 μ A	8 mA	High	-0.3	0.8	2	3.6	0.2	VCCI - 0.2	100 μ A	100 μ A
2.5 V LVCMOS	8 mA	8 mA	High	-0.3	0.7	1.7	3.6	0.7	1.7	8	8
1.8 V LVCMOS	4 mA	4 mA	High	-0.3	0.35 * VCCI	0.65 * VCCI	3.6	0.45	VCCI - 0.45	4	4
1.5 V LVCMOS	2 mA	2 mA	High	-0.3	0.35 * VCCI	0.65 * VCCI	3.6	0.25 * VCCI	0.75 * VCCI	2	2
1.2 V LVCMOS ⁴	1 mA	1 mA	High	-0.3	0.35 * VCCI	0.65 * VCCI	3.6	0.25 * VCCI	0.75 * VCCI	1	1
1.2 V LVCMOS Wide Range ^{4,5}	100 μ A	1 mA	High	-0.3	0.3 * VCCI	0.7 * VCCI	3.6	0.1	VCCI - 0.1	100 μ A	100 μ A

Notes:

1. Currents are measured at 85°C junction temperature.
2. The minimum drive strength for any LVCMOS 1.2 V or LVCMOS 3.3 V software configuration when run in wide range is $\pm 100 \mu$ A. Drive strength displayed in the software is supported for normal range only. For a detailed I/V curve, refer to the IBIS models.
3. All LVCMOS 3.3 V software macros support LVCMOS 3.3 V wide range, as specified in the JESD8-B specification.
4. Applicable to IGLOO nano V2 devices operating at VCCI \geq VCC.
5. All LVCMOS 1.2 V software macros support LVCMOS 1.2 V wide range, as specified in the JESD8-12 specification.

**Table 2-22 • Summary of Maximum and Minimum DC Input Levels
Applicable to Commercial and Industrial Conditions**

DC I/O Standards	Commercial ¹		Industrial ²	
	IIL ³	IIH ⁴	IIL ³	IIH ⁴
	μ A	μ A	μ A	μ A
3.3 V LVTTTL / 3.3 V LVCMOS	10	10	15	15
3.3 V LVCOMS Wide Range	10	10	15	15
2.5 V LVCMOS	10	10	15	15
1.8 V LVCMOS	10	10	15	15
1.5 V LVCMOS	10	10	15	15
1.2 V LVCMOS ⁵	10	10	15	15
1.2 V LVCMOS Wide Range ⁵	10	10	15	15

Notes:

1. Commercial range ($-20^{\circ}\text{C} < T_A < 70^{\circ}\text{C}$)
2. Industrial range ($-40^{\circ}\text{C} < T_A < 85^{\circ}\text{C}$)
3. I_{IH} is the input leakage current per I/O pin over recommended operating conditions, where $V_{IH} < V_{IN} < V_{CCI}$. Input current is larger when operating outside recommended ranges.
4. I_{IL} is the input leakage current per I/O pin over recommended operating conditions, where $-0.3 \text{ V} < V_{IN} < V_{IL}$.
5. Applicable to IGLOO nano V2 devices operating at VCCI \geq VCC.

Summary of I/O Timing Characteristics – Default I/O Software Settings

Table 2-23 • Summary of AC Measuring Points

Standard	Measuring Trip Point (Vtrip)
3.3 V LVTTTL / 3.3 V LVCMOS	1.4 V
3.3 V LVCMOS Wide Range	1.4 V
2.5 V LVCMOS	1.2 V
1.8 V LVCMOS	0.90 V
1.5 V LVCMOS	0.75 V
1.2 V LVCMOS	0.60 V
1.2 V LVCMOS Wide Range	0.60 V

Table 2-24 • I/O AC Parameter Definitions

Parameter	Parameter Definition
t_{DP}	Data to Pad delay through the Output Buffer
t_{PY}	Pad to Data delay through the Input Buffer
t_{DOUT}	Data to Output Buffer delay through the I/O interface
t_{EOUT}	Enable to Output Buffer Tristate Control delay through the I/O interface
t_{DIN}	Input Buffer to Data delay through the I/O interface
t_{HZ}	Enable to Pad delay through the Output Buffer—HIGH to Z
t_{ZH}	Enable to Pad delay through the Output Buffer—Z to HIGH
t_{LZ}	Enable to Pad delay through the Output Buffer—LOW to Z
t_{ZL}	Enable to Pad delay through the Output Buffer—Z to LOW
t_{ZHS}	Enable to Pad delay through the Output Buffer with delayed enable—Z to HIGH
t_{ZLS}	Enable to Pad delay through the Output Buffer with delayed enable—Z to LOW

Applies to IGLOO nano at 1.5 V Core Operating Conditions
Table 2-25 • Summary of I/O Timing Characteristics—Software Default Settings
 STD Speed Grade, Commercial-Case Conditions: $T_J = 70^\circ\text{C}$, Worst-Case $V_{CC} = 1.425\text{ V}$,
 Worst-Case $V_{CCI} = 3.0\text{ V}$

I/O Standard	Drive Strength (mA)	Equivalent Software Default t Drive Strength Option ¹	Slew Rate	Capacitive Load (pF)	t _{POUT}	t _{DP}	t _{DIN}	t _{PY}	t _{PYS}	t _{EOUT}	t _{ZL}	t _{ZH}	t _{LZ}	t _{HZ}	Units
3.3 V LVTTTL / 3.3 V LVCMOS	8 mA	8 mA	High	5 pF	0.97	1.79	0.19	0.86	1.16	0.66	1.83	1.45	1.98	2.38	ns
3.3 V LVCMOS Wide Range ²	100 μA	8 mA	High	5 pF	0.97	2.56	0.19	1.20	1.66	0.66	2.57	2.02	2.82	3.31	ns
2.5 V LVCMOS	8 mA	8 mA	High	5 pF	0.97	1.81	0.19	1.10	1.24	0.66	1.85	1.63	1.97	2.26	ns
1.8 V LVCMOS	4 mA	4 mA	High	5 pF	0.97	2.08	0.19	1.03	1.44	0.66	2.12	1.95	1.99	2.19	ns
1.5 V LVCMOS	2 mA	2 mA	High	5 pF	0.97	2.39	0.19	1.19	1.52	0.66	2.44	2.24	2.02	2.15	ns

Notes:

1. The minimum drive strength for any LVCMOS 1.2 V or LVCMOS 3.3 V software configuration when run in wide range is $\pm 100\ \mu\text{A}$. Drive strength displayed in the software is supported for normal range only. For a detailed I/V curve, refer to the IBIS models.
2. All LVCMOS 3.3 V software macros support LVCMOS 3.3 V wide range, as specified in the JESD8-B specification.
3. For specific junction temperature and voltage supply levels, refer to [Table 2-6 on page 2-6](#) for derating values.

Applies to IGLOO nano at 1.2 V Core Operating Conditions

Table 2-26 • Summary of I/O Timing Characteristics—Software Default Settings
STD Speed Grade, Commercial-Case Conditions: $T_J = 70^\circ\text{C}$, Worst-Case VCC = 1.14 V,
Worst-Case VCCI = 3.0 V

I/O Standard	Drive Strength (mA)	Equiv. Software Default Drive Strength Option ¹	Slew Rate	Capacitive Load (pF)	t_{DOUT}	t_{DP}	t_{DIN}	t_{PY}	t_{PYS}	t_{EOUT}	t_{ZL}	t_{ZH}	t_{LZ}	t_{HZ}	Units
3.3 V LVTTTL / 3.3 V LVCMOS	8 mA	8 mA	High	5 pF	1.55	2.31	0.26	0.97	1.36	1.10	2.34	1.90	2.43	3.14	ns
3.3 V LVCMOS Wide Range ²	100 μA	8 mA	High	5 pF	1.55	3.25	0.26	1.31	1.91	1.10	3.25	2.61	3.38	4.27	ns
2.5 V LVCMOS	8 mA	8 mA	High	5 pF	1.55	2.30	0.26	1.21	1.39	1.10	2.33	2.04	2.41	2.99	ns
1.8 V LVCMOS	4 mA	4 mA	High	5 pF	1.55	2.49	0.26	1.13	1.59	1.10	2.53	2.34	2.42	2.81	ns
1.5 V LVCMOS	2 mA	2 mA	High	5 pF	1.55	2.78	0.26	1.27	1.77	1.10	2.82	2.62	2.44	2.74	ns
1.2 V LVCMOS	1 mA	1 mA	High	5 pF	1.55	3.50	0.26	1.56	2.27	1.10	3.37	3.10	2.55	2.66	ns
1.2 V LVCMOS Wide Range ³	100 μA	1 mA	High	5 pF	1.55	3.50	0.26	1.56	2.27	1.10	3.37	3.10	2.55	2.66	ns

Notes:

1. The minimum drive strength for any LVCMOS 1.2 V or LVCMOS 3.3 V software configuration when run in wide range is $\pm 100 \mu\text{A}$. Drive strength displayed in the software is supported for normal range only. For a detailed I/V curve, refer to the IBIS models.
2. All LVCMOS 3.3 V software macros support LVCMOS 3.3 V wide range, as specified in the JESD8-B specification.
3. All LVCMOS 1.2 V software macros support LVCMOS 1.2 V side range as specified in the JESD8-12 specification.
4. For specific junction temperature and voltage supply levels, refer to [Table 2-6 on page 2-6](#) for derating values.

Detailed I/O DC Characteristics

Table 2-27 • Input Capacitance

Symbol	Definition	Conditions	Min.	Max.	Units
C _{IN}	Input capacitance	V _{IN} = 0, f = 1.0 MHz		8	pF
C _{INCLK}	Input capacitance on the clock pin	V _{IN} = 0, f = 1.0 MHz		8	pF

Table 2-28 • I/O Output Buffer Maximum Resistances¹

Standard	Drive Strength	R _{PULL-DOWN} (Ω) ²	R _{PULL-UP} (Ω) ³
3.3 V LVTTTL / 3.3V LVCMOS	2 mA	100	300
	4 mA	100	300
	6 mA	50	150
	8 mA	50	150
3.3 V LVCMOS Wide Range	100 μA	Same as equivalent software default drive	
2.5 V LVCMOS	2 mA	100	200
	4 mA	100	200
	6 mA	50	100
	8 mA	50	100
1.8 V LVCMOS	2 mA	200	225
	4 mA	100	112
1.5 V LVCMOS	2 mA	200	224
1.2 V LVCMOS ⁴	1 mA	315	315
1.2 V LVCMOS Wide Range ⁴	100 μA	315	315

Notes:

1. These maximum values are provided for informational reasons only. Minimum output buffer resistance values depend on VCCI, drive strength selection, temperature, and process. For board design considerations and detailed output buffer resistances, use the corresponding IBIS models posted at <http://www.microsemi.com/soc/download/ibis/default.aspx>.
2. $R_{(PULL-DOWN-MAX)} = (VOL_{spec}) / IOL_{spec}$
3. $R_{(PULL-UP-MAX)} = (VCCImax - VOH_{spec}) / IOH_{spec}$
4. Applicable to IGLOO nano V2 devices operating at VCCI ≥ VCC.

Table 2-29 • I/O Weak Pull-Up/Pull-Down Resistances
Minimum and Maximum Weak Pull-Up/Pull-Down Resistance Values

VCCI	$R_{(WEAK\ PULL-UP)}^1 (\Omega)$		$R_{(WEAK\ PULL-DOWN)}^2 (\Omega)$	
	Min.	Max.	Min.	Max.
3.3 V	10 K	45 K	10 K	45 K
3.3 V (wide range I/Os)	10 K	45 K	10 K	45 K
2.5 V	11 K	55 K	12 K	74 K
1.8 V	18 K	70 K	17 K	110 K
1.5 V	19 K	90 K	19 K	140 K
1.2 V	25 K	110 K	25 K	150 K
1.2 V (wide range I/Os)	19 K	110 K	19 K	150 K

Notes:

1. $R_{(WEAK\ PULL-UP-MAX)} = (VCCI_{max} - VOH_{spec}) / I_{(WEAK\ PULL-UP-MIN)}$
2. $R_{(WEAK\ PULL-DOWN-MAX)} = (VOL_{spec}) / I_{(WEAK\ PULL-DOWN-MIN)}$

Table 2-30 • I/O Short Currents IOSH/IOSL

	Drive Strength	IOSL (mA)*	IOSH (mA)*
3.3 V LVTTTL / 3.3 V LVCMOS	2 mA	25	27
	4 mA	25	27
	6 mA	51	54
	8 mA	51	54
3.3 V LVCMOS Wide Range	100 μ A	Same as equivalent software default drive	
2.5 V LVCMOS	2 mA	16	18
	4 mA	16	18
	6 mA	32	37
	8 mA	32	37
1.8 V LVCMOS	2 mA	9	11
	4 mA	17	22
1.5 V LVCMOS	2 mA	13	16
1.2 V LVCMOS	1 mA	10	13
1.2 V LVCMOS Wide Range	100 μ A	10	13

Note: * $T_J = 100^\circ\text{C}$

The length of time an I/O can withstand IOSH/IOSL events depends on the junction temperature. The reliability data below is based on a 3.3 V, 8 mA I/O setting, which is the worst case for this type of analysis.

For example, at 100°C, the short current condition would have to be sustained for more than six months to cause a reliability concern. The I/O design does not contain any short circuit protection, but such protection would only be needed in extremely prolonged stress conditions.

Table 2-31 • Duration of Short Circuit Event before Failure

Temperature	Time before Failure
-40°C	> 20 years
-20°C	> 20 years
0°C	> 20 years
25°C	> 20 years
70°C	5 years
85°C	2 years
100°C	6 months

Table 2-32 • Schmitt Trigger Input Hysteresis Hysteresis Voltage Value (Typ.) for Schmitt Mode Input Buffers

Input Buffer Configuration	Hysteresis Value (typ.)
3.3 V LVTTTL / LVCMOS (Schmitt trigger mode)	240 mV
2.5 V LVCMOS (Schmitt trigger mode)	140 mV
1.8 V LVCMOS (Schmitt trigger mode)	80 mV
1.5 V LVCMOS (Schmitt trigger mode)	60 mV
1.2 V LVCMOS (Schmitt trigger mode)	40 mV

Table 2-33 • I/O Input Rise Time, Fall Time, and Related I/O Reliability

Input Buffer	Input Rise/Fall Time (min.)	Input Rise/Fall Time (max.)	Reliability
LVTTTL/LVCMOS (Schmitt trigger disabled)	No requirement	10 ns *	20 years (100°C)
LVTTTL/LVCMOS (Schmitt trigger enabled)	No requirement	No requirement, but input noise voltage cannot exceed Schmitt hysteresis.	20 years (100°C)

Note: *The maximum input rise/fall time is related to the noise induced into the input buffer trace. If the noise is low, then the rise time and fall time of input buffers can be increased beyond the maximum value. The longer the rise/fall times, the more susceptible the input signal is to the board noise. Microsemi recommends signal integrity evaluation/characterization of the system to ensure that there is no excessive noise coupling into input signals.

Single-Ended I/O Characteristics

3.3 V LVTTTL / 3.3 V LVCMOS

Low-Voltage Transistor–Transistor Logic (LVTTTL) is a general purpose standard (EIA/JESD) for 3.3 V applications. It uses an LVTTTL input buffer and push-pull output buffer.

Table 2-34 • Minimum and Maximum DC Input and Output Levels

3.3 V LVTTTL / 3.3 V LVCMOS	VIL		VIH		VOL	VOH	IOL	IOH	IOSL	IOSH	IIL ¹	IIH ²
	Min. V	Max. V	Min. V	Max. V	Max. V	Min. V	mA	mA	Max. mA ³	Max. mA ³	μA ⁴	μA ⁴
2 mA	-0.3	0.8	2	3.6	0.4	2.4	2	2	25	27	10	10
4 mA	-0.3	0.8	2	3.6	0.4	2.4	4	4	25	27	10	10
6 mA	-0.3	0.8	2	3.6	0.4	2.4	6	6	51	54	10	10
8 mA	-0.3	0.8	2	3.6	0.4	2.4	8	8	51	54	10	10

Notes:

1. I_{IL} is the input leakage current per I/O pin over recommended operating conditions where $-0.3 < V_{IN} < V_{IL}$.
2. I_{IH} is the input leakage current per I/O pin over recommended operating conditions where $V_{IH} < V_{IN} < V_{CCI}$. Input current is larger when operating outside recommended ranges.
3. Currents are measured at high temperature (100°C junction temperature) and maximum voltage.
4. Currents are measured at 85°C junction temperature.
5. Software default selection highlighted in gray.

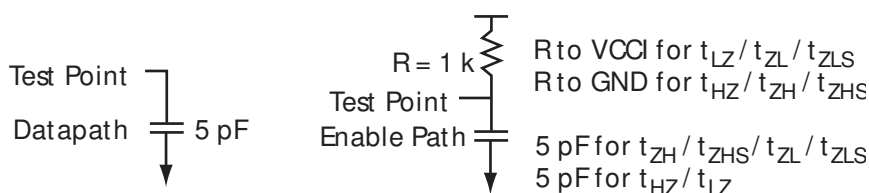

Figure 2-7 • AC Loading

Table 2-35 • 3.3 V LVTTTL/LVCMOS AC Waveforms, Measuring Points, and Capacitive Loads

Input LOW (V)	Input HIGH (V)	Measuring Point* (V)	C _{LOAD} (pF)
0	3.3	1.4	5

Note: *Measuring point = Vtrip. See Table 2-23 on page 2-20 for a complete table of trip points.

Timing Characteristics

Applies to 1.5 V DC Core Voltage

Table 2-36 • 3.3 V LVTTTL / 3.3 V LVCMOS Low Slew – Applies to 1.5 V DC Core Voltage
Commercial-Case Conditions: $T_J = 70^\circ\text{C}$, Worst-Case $V_{CC} = 1.425\text{ V}$, Worst-Case $V_{CCI} = 3.0\text{ V}$

Drive Strength	Speed Grade	t_{DOUT}	t_{DP}	t_{DIN}	t_{PY}	t_{PYS}	t_{EOUT}	t_{ZL}	t_{ZH}	t_{LZ}	t_{HZ}	Units
2 mA	STD	0.97	3.52	0.19	0.86	1.16	0.66	3.59	3.42	1.75	1.90	ns
4 mA	STD	0.97	3.52	0.19	0.86	1.16	0.66	3.59	3.42	1.75	1.90	ns
6 mA	STD	0.97	2.90	0.19	0.86	1.16	0.66	2.96	2.83	1.98	2.29	ns
8 mA	STD	0.97	2.90	0.19	0.86	1.16	0.66	2.96	2.83	1.98	2.29	ns

Note: For specific junction temperature and voltage supply levels, refer to [Table 2-6 on page 2-6](#) for derating values.

Table 2-37 • 3.3 V LVTTTL / 3.3 V LVCMOS High Slew – Applies to 1.5 V DC Core Voltage
Commercial-Case Conditions: $T_J = 70^\circ\text{C}$, Worst-Case $V_{CC} = 1.425\text{ V}$, Worst-Case $V_{CCI} = 3.0\text{ V}$

Drive Strength	Speed Grade	t_{DOUT}	t_{DP}	t_{DIN}	t_{PY}	t_{PYS}	t_{EOUT}	t_{ZL}	t_{ZH}	t_{LZ}	t_{HZ}	Units
2 mA	STD	0.97	2.16	0.19	0.86	1.16	0.66	2.20	1.80	1.75	1.99	ns
4 mA	STD	0.97	2.16	0.19	0.86	1.16	0.66	2.20	1.80	1.75	1.99	ns
6 mA	STD	0.97	1.79	0.19	0.86	1.16	0.66	1.83	1.45	1.98	2.38	ns
8 mA	STD	0.97	1.79	0.19	0.86	1.16	0.66	1.83	1.45	1.98	2.38	ns

Notes:

1. Software default selection highlighted in gray.
2. For specific junction temperature and voltage supply levels, refer to [Table 2-6 on page 2-6](#) for derating values.

Applies to 1.2 V DC Core Voltage

Table 2-38 • 3.3 V LVTTTL / 3.3 V LVCMOS Low Slew – Applies to 1.2 V DC Core Voltage
Commercial-Case Conditions: $T_J = 70^\circ\text{C}$, Worst-Case VCC = 1.14 V, Worst-Case VCCI = 3.0 V

Drive Strength	Speed Grade	t_{DOUT}	t_{DP}	t_{DIN}	t_{PY}	t_{PYS}	t_{EOUT}	t_{ZL}	t_{ZH}	t_{LZ}	t_{HZ}	Units
2 mA	STD	1.55	4.09	0.26	0.97	1.36	1.10	4.16	3.91	2.19	2.64	ns
4 mA	STD	1.55	4.09	0.26	0.97	1.36	1.10	4.16	3.91	2.19	2.64	ns
6 mA	STD	1.55	3.45	0.26	0.97	1.36	1.10	3.51	3.32	2.43	3.03	ns
8 mA	STD	1.55	3.45	0.26	0.97	1.36	1.10	3.51	3.32	2.43	3.03	ns

Note: For specific junction temperature and voltage supply levels, refer to [Table 2-6 on page 2-6](#) for derating values.

Table 2-39 • 3.3 V LVTTTL / 3.3 V LVCMOS High Slew – Applies to 1.2 V DC Core Voltage
Commercial-Case Conditions: $T_J = 70^\circ\text{C}$, Worst-Case VCC = 1.14 V, Worst-Case VCCI = 3.0 V

Drive Strength	Speed Grade	t_{DOUT}	t_{DP}	t_{DIN}	t_{PY}	t_{PYS}	t_{EOUT}	t_{ZL}	t_{ZH}	t_{LZ}	t_{HZ}	Units
2 mA	STD	1.55	2.68	0.26	0.97	1.36	1.10	2.72	2.26	2.19	2.74	ns
4 mA	STD	1.55	2.68	0.26	0.97	1.36	1.10	2.72	2.26	2.19	2.74	ns
6 mA	STD	1.55	2.31	0.26	0.97	1.36	1.10	2.34	1.90	2.43	3.14	ns
8 mA	STD	1.55	2.31	0.26	0.97	1.36	1.10	2.34	1.90	2.43	3.14	ns

Notes:

1. Software default selection highlighted in gray.
2. For specific junction temperature and voltage supply levels, refer to [Table 2-6 on page 2-6](#) for derating values.

3.3 V LVCMOS Wide Range

Table 2-40 • Minimum and Maximum DC Input and Output Levels for LVCMOS 3.3 V Wide Range

3.3 V LVCMOS Wide Range ¹	Equivalent Software Default Drive Strength Option ⁴	VIL		VIH		VOL	VOH	IOL	I _{OH}	IIL ²	IIH ³
		Min. V	Max. V	Min. V	Max. V	Max. V	Min. V	μA	μA	μA ⁵	μA ⁵
	2 mA	-0.3	0.8	2	3.6	0.2	VCCI - 0.2	100	100	10	10
	4 mA	-0.3	0.8	2	3.6	0.2	VCCI - 0.2	100	100	10	10
	6 mA	-0.3	0.8	2	3.6	0.2	VCCI - 0.2	100	100	10	10
	8 mA	-0.3	0.8	2	3.6	0.2	VCCI - 0.2	100	100	10	10

Notes:

1. All LVCMOS 3.3 V software macros support LVCMOS 3.3 V Wide Range, as specified in the JEDEC JESD8-B specification.
2. I_{IL} is the input leakage current per I/O pin over recommended operating conditions where $-0.3 < V_{IN} < V_{IL}$.
3. I_{IH} is the input leakage current per I/O pin over recommended operating conditions where $V_{IH} < V_{IN} < V_{CCI}$. Input current is larger when operating outside recommended ranges.
4. The minimum drive strength for any LVCMOS 3.3 V software configuration when run in wide range is $\pm 100 \mu A$. Drive strength displayed in the software is supported for normal range only. For a detailed I/V curve, refer to the IBIS models.
5. Currents are measured at 85°C junction temperature.
6. Software default selection is highlighted in gray.

Timing Characteristics

Applies to 1.5 V DC Core Voltage

Table 2-41 • 3.3 V LVC MOS Wide Range Low Slew – Applies to 1.5 V DC Core Voltage
Commercial-Case Conditions: $T_J = 70^\circ\text{C}$, Worst-Case VCC = 1.425 V, Worst-Case VCCI = 2.7 V

Drive Strength	Equivalent Software Default Drive Strength Option ¹	Speed Grade	t_{DOUT}	t_{DP}	t_{DIN}	t_{PY}	t_{PYS}	t_{EOUT}	t_{ZL}	t_{ZH}	t_{LZ}	t_{HZ}	Units
100 μA	2 mA	STD	0.97	5.23	0.19	1.20	1.66	0.66	5.24	5.00	2.47	2.56	ns
100 μA	4 mA	STD	0.97	5.23	0.19	1.20	1.66	0.66	5.24	5.00	2.47	2.56	ns
100 μA	6 mA	STD	0.97	4.27	0.19	1.20	1.66	0.66	4.28	4.12	2.83	3.16	ns
100 μA	8 mA	STD	0.97	4.27	0.19	1.20	1.66	0.66	4.28	4.12	2.83	3.16	ns

Notes:

1. The minimum drive strength for any LVC MOS 3.3 V software configuration when run in wide range is $\pm 100 \mu\text{A}$. Drive strength displayed in the software is supported for normal range only. For a detailed I/V curve, refer to the IBIS models.
2. For specific junction temperature and voltage supply levels, refer to [Table 2-6 on page 2-6](#) for derating values.

Table 2-42 • 3.3 V LVC MOS Wide Range High Slew – Applies to 1.5 V DC Core Voltage
Commercial-Case Conditions: $T_J = 70^\circ\text{C}$, Worst-Case VCC = 1.425 V, Worst-Case VCCI = 2.7 V

Drive Strength	Equivalent Software Default Drive Strength Option ¹	Speed Grade	t_{DOUT}	t_{DP}	t_{DIN}	t_{PY}	t_{PYS}	t_{EOUT}	t_{ZL}	t_{ZH}	t_{LZ}	t_{HZ}	Units
100 μA	2 mA	STD	0.97	3.11	0.19	1.20	1.66	0.66	3.13	2.55	2.47	2.70	ns
100 μA	4 mA	STD	0.97	3.11	0.19	1.20	1.66	0.66	3.13	2.55	2.47	2.70	ns
100 μA	6 mA	STD	0.97	2.56	0.19	1.20	1.66	0.66	2.57	2.02	2.82	3.31	ns
100 μA	8 mA	STD	0.97	2.56	0.19	1.20	1.66	0.66	2.57	2.02	2.82	3.31	ns

Notes:

1. The minimum drive strength for any LVC MOS 3.3 V software configuration when run in wide range is $\pm 100 \mu\text{A}$. Drive strength displayed in the software is supported for normal range only. For a detailed I/V curve, refer to the IBIS models.
2. For specific junction temperature and voltage supply levels, refer to [Table 2-6 on page 2-6](#) for derating values.
3. Software default selection highlighted in gray.

Applies to 1.2 V DC Core Voltage

Table 2-43 • 3.3 V LVCMOS Wide Range Low Slew – Applies to 1.2 V DC Core Voltage
Commercial-Case Conditions: $T_J = 70^\circ\text{C}$, Worst-Case VCC = 1.14 V, Worst-Case VCCI = 2.7 V

Drive Strength	Equivalent Software Default Drive Strength Option ¹	Speed Grade	t_{DOUT}	t_{DP}	t_{DIN}	t_{PY}	t_{PYS}	t_{EOUT}	t_{ZL}	t_{ZH}	t_{LZ}	t_{HZ}	Units
100 μA	2 mA	STD	1.55	6.01	0.26	1.31	1.91	1.10	6.01	5.66	3.02	3.49	ns
100 μA	4 mA	STD	1.55	6.01	0.26	1.31	1.91	1.10	6.01	5.66	3.02	3.49	ns
100 μA	6 mA	STD	1.55	5.02	0.26	1.31	1.91	1.10	5.02	4.76	3.38	4.10	ns
100 μA	8 mA	STD	1.55	5.02	0.26	1.31	1.91	1.10	5.02	4.76	3.38	4.10	ns

Notes:

1. The minimum drive strength for any LVCMOS 3.3 V software configuration when run in wide range is $\pm 100 \mu\text{A}$. Drive strength displayed in the software is supported for normal range only. For a detailed I/V curve, refer to the IBIS models.
2. For specific junction temperature and voltage supply levels, refer to [Table 2-6 on page 2-6](#) for derating values.

Table 2-44 • 3.3 V LVCMOS Wide Range High Slew – Applies to 1.2 V DC Core Voltage
Commercial-Case Conditions: $T_J = 70^\circ\text{C}$, Worst-Case VCC = 1.14 V, Worst-Case VCCI = 2.7 V

Drive Strength	Equivalent Software Default Drive Strength Option ¹	Speed Grade	t_{DOUT}	t_{DP}	t_{DIN}	t_{PY}	t_{PYS}	t_{EOUT}	t_{ZL}	t_{ZH}	t_{LZ}	t_{HZ}	Units
100 μA	2 mA	STD	1.55	3.82	0.26	1.31	1.91	1.10	3.82	3.15	3.01	3.65	ns
100 μA	4 mA	STD	1.55	3.82	0.26	1.31	1.91	1.10	3.82	3.15	3.01	3.65	ns
100 μA	6 mA	STD	1.55	3.25	0.26	1.31	1.91	1.10	3.25	2.61	3.38	4.27	ns
100 μA	8 mA	STD	1.55	3.25	0.26	1.31	1.91	1.10	3.25	2.61	3.38	4.27	ns

Notes:

1. The minimum drive strength for any LVCMOS 3.3 V software configuration when run in wide range is $\pm 100 \mu\text{A}$. Drive strength displayed in the software is supported for normal range only. For a detailed I/V curve, refer to the IBIS models.
2. For specific junction temperature and voltage supply levels, refer to [Table 2-6 on page 2-6](#) for derating values.
3. Software default selection highlighted in gray.

2.5 V LVCMOS

Low-Voltage CMOS for 2.5 V is an extension of the LVCMOS standard (JEDEC8-5) used for general purpose 2.5 V applications.

Table 2-45 • Minimum and Maximum DC Input and Output Levels

2.5 V LVCMOS	VIL		VIH		VOL	VOH	IOL	IOH	IOSL	IOSH	IIL ¹	IIH ²
	Min., V	Max., V	Min., V	Max., V	Max., V	Min., V	mA	mA	Max., mA ³	Max., mA ³	μA ⁴	μA ⁴
2 mA	-0.3	0.7	1.7	3.6	0.7	1.7	2	2	16	18	10	10
4 mA	-0.3	0.7	1.7	3.6	0.7	1.7	4	4	16	18	10	10
6 mA	-0.3	0.7	1.7	3.6	0.7	1.7	6	6	32	37	10	10
8 mA	-0.3	0.7	1.7	3.6	0.7	1.7	8	8	32	37	10	10

Notes:

1. I_{IL} is the input leakage current per I/O pin over recommended operating conditions where $-0.3 < V_{IN} < V_{IL}$.
2. I_{IH} is the input leakage current per I/O pin over recommended operating conditions where $V_{IH} < V_{IN} < V_{CCI}$. Input current is larger when operating outside recommended ranges.
3. Currents are measured at high temperature (100°C junction temperature) and maximum voltage.
4. Currents are measured at 85°C junction temperature.
5. Software default selection highlighted in gray.

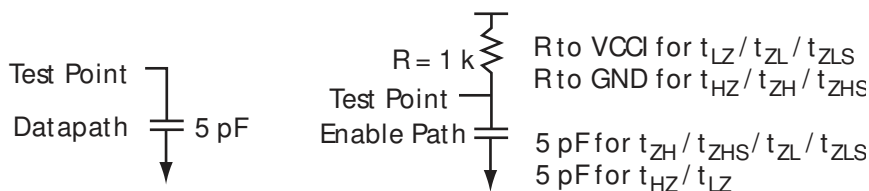

Figure 2-8 • AC Loading

Table 2-46 • 2.5 V LVCMOS AC Waveforms, Measuring Points, and Capacitive Loads

Input LOW (V)	Input HIGH (V)	Measuring Point* (V)	C _{LOAD} (pF)
0	2.5	1.2	5

Note: *Measuring point = V_{trip} . See Table 2-23 on page 2-20 for a complete table of trip points.

Timing Characteristics

Applies to 1.5 V DC Core Voltage

Table 2-47 • 2.5 V LVCMOS Low Slew – Applies to 1.5 V DC Core Voltage

Commercial-Case Conditions: $T_J = 70^\circ\text{C}$, Worst-Case VCC = 1.425 V, Worst-Case VCCI = 2.3 V

Drive Strength	Speed Grade	t_{DOUT}	t_{DP}	t_{DIN}	t_{PY}	t_{PYS}	t_{EOUT}	t_{ZL}	t_{ZH}	t_{LZ}	t_{HZ}	Units
2 mA	STD	0.97	4.13	0.19	1.10	1.24	0.66	4.01	4.13	1.73	1.74	ns
4 mA	STD	0.97	4.13	0.19	1.10	1.24	0.66	4.01	4.13	1.73	1.74	ns
8 mA	STD	0.97	3.39	0.19	1.10	1.24	0.66	3.31	3.39	1.98	2.19	ns
8 mA	STD	0.97	3.39	0.19	1.10	1.24	0.66	3.31	3.39	1.98	2.19	ns

Note: For specific junction temperature and voltage supply levels, refer to [Table 2-6 on page 2-6](#) for derating values.

Table 2-48 • 2.5 V LVCMOS High Slew – Applies to 1.5 V DC Core Voltage

Commercial-Case Conditions: $T_J = 70^\circ\text{C}$, Worst-Case VCC = 1.425 V, Worst-Case VCCI = 2.3 V

Drive Strength	Speed Grade	t_{DOUT}	t_{DP}	t_{DIN}	t_{PY}	t_{PYS}	t_{EOUT}	t_{ZL}	t_{ZH}	t_{LZ}	t_{HZ}	Units
2 mA	STD	0.97	2.19	0.19	1.10	1.24	0.66	2.23	2.11	1.72	1.80	ns
4 mA	STD	0.97	2.19	0.19	1.10	1.24	0.66	2.23	2.11	1.72	1.80	ns
6 mA	STD	0.97	1.81	0.19	1.10	1.24	0.66	1.85	1.63	1.97	2.26	ns
8 mA	STD	0.97	1.81	0.19	1.10	1.24	0.66	1.85	1.63	1.97	2.26	ns

Notes:

1. Software default selection highlighted in gray.
2. For specific junction temperature and voltage supply levels, refer to [Table 2-6 on page 2-6](#) for derating values.

Applies to 1.2 V DC Core Voltage

Table 2-49 • 2.5 LVCMOS Low Slew – Applies to 1.2 V DC Core Voltage
Commercial-Case Conditions: $T_J = 70^\circ\text{C}$, Worst-Case VCC = 1.14 V, Worst-Case VCCI = 2.3 V

Drive Strength	Speed Grade	t_{DOUT}	t_{DP}	t_{DIN}	t_{PY}	t_{PYS}	t_{EOUT}	t_{ZL}	t_{ZH}	t_{LZ}	t_{HZ}	Units
2 mA	STD	1.55	4.61	0.26	1.21	1.39	1.10	4.55	4.61	2.15	2.43	ns
4 mA	STD	1.55	4.61	0.26	1.21	1.39	1.10	4.55	4.61	2.15	2.43	ns
6 mA	STD	1.55	3.86	0.26	1.21	1.39	1.10	3.82	3.86	2.41	2.89	ns
8 mA	STD	1.55	3.86	0.26	1.21	1.39	1.10	3.82	3.86	2.41	2.89	ns

Note: For specific junction temperature and voltage supply levels, refer to [Table 2-6 on page 2-6](#) for derating values.

Table 2-50 • 2.5 V LVCMOS High Slew – Applies to 1.2 V DC Core Voltage
Commercial-Case Conditions: $T_J = 70^\circ\text{C}$, Worst-Case VCC = 1.14 V, Worst-Case VCCI = 2.3 V

Drive Strength	Speed Grade	t_{DOUT}	t_{DP}	t_{DIN}	t_{PY}	t_{PYS}	t_{EOUT}	t_{ZL}	t_{ZH}	t_{LZ}	t_{HZ}	Units
2 mA	STD	1.55	2.68	0.26	1.21	1.39	1.10	2.72	2.54	2.15	2.51	ns
4 mA	STD	1.55	2.68	0.26	1.21	1.39	1.10	2.72	2.54	2.15	2.51	ns
6 mA	STD	1.55	2.30	0.26	1.21	1.39	1.10	2.33	2.04	2.41	2.99	ns
8 mA	STD	1.55	2.30	0.26	1.21	1.39	1.10	2.33	2.04	2.41	2.99	ns

Notes:

1. Software default selection highlighted in gray.
2. For specific junction temperature and voltage supply levels, refer to [Table 2-6 on page 2-6](#) for derating values.

1.8 V LVCMOS

Low-voltage CMOS for 1.8 V is an extension of the LVCMOS standard (JEDEC8-5) used for general purpose 1.8 V applications. It uses a 1.8 V input buffer and a push-pull output buffer.

Table 2-51 • Minimum and Maximum DC Input and Output Levels

1.8 V LVCMOS	VIL		VIH		VOL	VOH	IOL	IOH	IOSL	IOSH	IIL ¹	I _{IH} ²
	Min. V	Max. V	Min. V	Max. V	Max. V	Min. V	mA	mA	Max. mA ³	Max. mA ³	μA ⁴	μA ⁴
2 mA	-0.3	0.35 * VCCI	0.65 * VCCI	3.6	0.45	VCCI - 0.45	2	2	9	11	10	10
4 mA	-0.3	0.35 * VCCI	0.65 * VCCI	3.6	0.45	VCCI - 0.45	4	4	17	22	10	10

Notes:

1. I_{IL} is the input leakage current per I/O pin over recommended operating conditions where $-0.3 < V_{IN} < V_{IL}$.
2. I_{IH} is the input leakage current per I/O pin over recommended operating conditions where $V_{IH} < V_{IN} < V_{CCI}$. Input current is larger when operating outside recommended ranges.
3. Currents are measured at high temperature (100°C junction temperature) and maximum voltage.
4. Currents are measured at 85°C junction temperature.
5. Software default selection highlighted in gray.

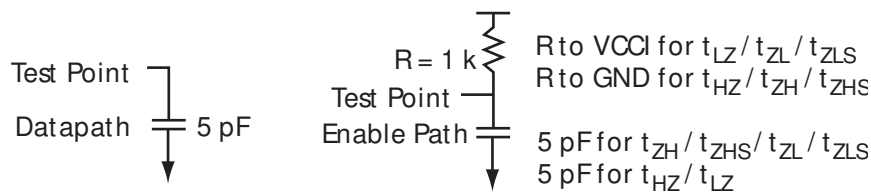

Figure 2-9 • AC Loading

Table 2-52 • 1.8 V LVCMOS AC Waveforms, Measuring Points, and Capacitive Loads

Input LOW (V)	Input HIGH (V)	Measuring Point* (V)	C _{LOAD} (pF)
0	1.8	0.9	5

Note: *Measuring point = V_{trip} . See Table 2-23 on page 2-20 for a complete table of trip points.

Timing Characteristics

Applies to 1.5 V DC Core Voltage

Table 2-53 • 1.8 V LVCMOS Low Slew – Applies to 1.5 V DC Core Voltage

Commercial-Case Conditions: $T_J = 70^\circ\text{C}$, Worst-Case VCC = 1.425 V, Worst-Case VCCI = 1.7 V

Drive Strength	Speed Grade	t_{DOUT}	t_{DP}	t_{DIN}	t_{PY}	t_{PYS}	t_{EOUT}	t_{ZL}	t_{ZH}	t_{LZ}	t_{HZ}	Units
2 mA	STD	0.97	5.44	0.19	1.03	1.44	0.66	5.25	5.44	1.69	1.35	ns
4 mA	STD	0.97	4.44	0.19	1.03	1.44	0.66	4.37	4.44	1.99	2.11	ns

Note: For specific junction temperature and voltage supply levels, refer to Table 2-6 on page 2-6 for derating values.

Table 2-54 • 1.8 V LVCMOS High Slew – Applies to 1.5 V DC Core Voltage

Commercial-Case Conditions: $T_J = 70^\circ\text{C}$, Worst-Case VCC = 1.425 V, Worst-Case VCCI = 1.7 V

Drive Strength	Speed Grade	t_{DOUT}	t_{DP}	t_{DIN}	t_{PY}	t_{PYS}	t_{EOUT}	t_{ZL}	t_{ZH}	t_{LZ}	t_{HZ}	Units
2 mA	STD	0.97	2.64	0.19	1.03	1.44	0.66	2.59	2.64	1.69	1.40	ns
4 mA	STD	0.97	2.08	0.19	1.03	1.44	0.66	2.12	1.95	1.99	2.19	ns

Notes:

1. Software default selection highlighted in gray.
2. For specific junction temperature and voltage supply levels, refer to Table 2-6 on page 2-6 for derating values.

Applies to 1.2 V DC Core Voltage

Table 2-55 • 1.8 V LVCMOS Low Slew – Applies to 1.2 V DC Core Voltage

Commercial-Case Conditions: $T_J = 70^\circ\text{C}$, Worst-Case VCC = 1.14 V, Worst-Case VCCI = 1.7 V

Drive Strength	Speed Grade	t_{DOUT}	t_{DP}	t_{DIN}	t_{PY}	t_{PYS}	t_{EOUT}	t_{ZL}	t_{ZH}	t_{LZ}	t_{HZ}	Units
2 mA	STD	1.55	5.92	0.26	1.13	1.59	1.10	5.72	5.92	2.11	1.95	ns
4 mA	STD	1.55	4.91	0.26	1.13	1.59	1.10	4.82	4.91	2.42	2.73	ns

Note: For specific junction temperature and voltage supply levels, refer to Table 2-6 on page 2-6 for derating values.

Table 2-56 • 1.8 V LVCMOS High Slew – Applies to 1.2 V DC Core Voltage

Commercial-Case Conditions: $T_J = 70^\circ\text{C}$, Worst-Case VCC = 1.14 V, Worst-Case VCCI = 1.7 V

Drive Strength	Speed Grade	t_{DOUT}	t_{DP}	t_{DIN}	t_{PY}	t_{PYS}	t_{EOUT}	t_{ZL}	t_{ZH}	t_{LZ}	t_{HZ}	Units
2 mA	STD	1.55	3.05	0.26	1.13	1.59	1.10	3.01	3.05	2.10	2.00	ns
4 mA	STD	1.55	2.49	0.26	1.13	1.59	1.10	2.53	2.34	2.42	2.81	ns

Notes:

1. Software default selection highlighted in gray.
2. For specific junction temperature and voltage supply levels, refer to Table 2-6 on page 2-6 for derating values.

1.5 V LVCMOS (JESD8-11)

Low-Voltage CMOS for 1.5 V is an extension of the LVCMOS standard (JESD8-5) used for general purpose 1.5 V applications. It uses a 1.5 V input buffer and a push-pull output buffer.

Table 2-57 • Minimum and Maximum DC Input and Output Levels

1.5 V LVCMOS	VIL		VIH		VOL	VOH	IOL	IOH	IOSL	IOSH	IIL ¹	IIH ²
	Min. V	Max. V	Min. V	Max. V	Max. V	Min. V	mA	mA	Max. mA ³	Max. mA ³	μA ⁴	μA ⁴
2 mA	-0.3	0.35 * VCCI	0.65 * VCCI	3.6	0.25 * VCCI	0.75 * VCCI	2	2	13	16	10	10

Notes:

1. I_{IL} is the input leakage current per I/O pin over recommended operating conditions where $-0.3 < V_{IN} < V_{IL}$.
2. IIH is the input leakage current per I/O pin over recommended operating conditions where $V_{IH} < V_{IN} < V_{CCI}$. Input current is larger when operating outside recommended ranges.
3. Currents are measured at high temperature (100°C junction temperature) and maximum voltage.
4. Currents are measured at 85°C junction temperature.
5. Software default selection highlighted in gray.

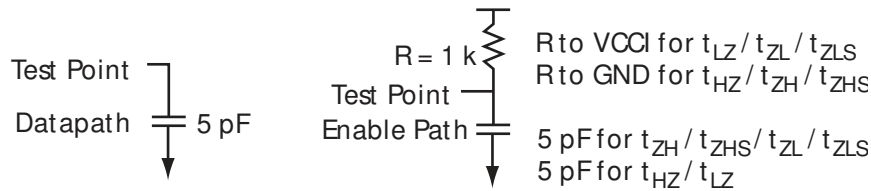

Figure 2-10 • AC Loading

Table 2-58 • 1.5 V LVCMOS AC Waveforms, Measuring Points, and Capacitive Loads

Input LOW (V)	Input HIGH (V)	Measuring Point* (V)	C _{LOAD} (pF)
0	1.5	0.75	5

Note: *Measuring point = V_{trip} . See Table 2-23 on page 2-20 for a complete table of trip points.

Timing Characteristics

Applies to 1.5 V DC Core Voltage

Table 2-59 • 1.5 V LVCMOS Low Slew – Applies to 1.5 V DC Core Voltage
Commercial-Case Conditions: $T_J = 70^\circ\text{C}$, Worst-Case VCC = 1.425 V, Worst-Case VCCI = 1.4 V

Drive Strength	Speed Grade	t_{DOUT}	t_{DP}	t_{DIN}	t_{PY}	t_{PYS}	t_{EOUT}	t_{ZL}	t_{ZH}	t_{LZ}	t_{HZ}	Units
2 mA	STD	0.97	5.39	0.19	1.19	1.62	0.66	5.48	5.39	2.02	2.06	ns

Note: For specific junction temperature and voltage supply levels, refer to Table 2-6 on page 2-6 for derating values.

Table 2-60 • 1.5 V LVCMOS High Slew – Applies to 1.5 V DC Core Voltage
Commercial-Case Conditions: $T_J = 70^\circ\text{C}$, Worst-Case VCC = 1.425 V, Worst-Case VCCI = 1.4 V

Drive Strength	Speed Grade	t_{DOUT}	t_{DP}	t_{DIN}	t_{PY}	t_{PYS}	t_{EOUT}	t_{ZL}	t_{ZH}	t_{LZ}	t_{HZ}	Units
2 mA	STD	0.97	2.39	0.19	1.19	1.62	0.66	2.44	2.24	2.02	2.15	ns

Notes:

1. Software default selection highlighted in gray.
2. For specific junction temperature and voltage supply levels, refer to Table 2-6 on page 2-6 for derating values.

Applies to 1.2 V DC Core Voltage

Table 2-61 • 1.5 V LVCMOS Low Slew – Applies to 1.2 V DC Core Voltage
Commercial-Case Conditions: $T_J = 70^\circ\text{C}$, Worst-Case VCC = 1.14 V, Worst-Case VCCI = 1.4 V

Drive Strength	Speed Grade	t_{DOUT}	t_{DP}	t_{DIN}	t_{PY}	t_{PYS}	t_{EOUT}	t_{ZL}	t_{ZH}	t_{LZ}	t_{HZ}	Units
2 mA	STD	1.55	5.87	0.26	1.27	1.77	1.10	5.92	5.87	2.45	2.65	ns

Note: For specific junction temperature and voltage supply levels, refer to Table 2-6 on page 2-6 for derating values.

Table 2-62 • 1.5 V LVCMOS High Slew – Applies to 1.2 V DC Core Voltage
Commercial-Case Conditions: $T_J = 70^\circ\text{C}$, Worst-Case VCC = 1.14 V, Worst-Case VCCI = 1.4 V

Drive Strength	Speed Grade	t_{DOUT}	t_{DP}	t_{DIN}	t_{PY}	t_{PYS}	t_{EOUT}	t_{ZL}	t_{ZH}	t_{LZ}	t_{HZ}	Units
2 mA	STD	1.55	2.78	0.26	1.27	1.77	1.10	2.82	2.62	2.44	2.74	ns

Notes:

1. Software default selection highlighted in gray.
2. For specific junction temperature and voltage supply levels, refer to Table 2-6 on page 2-6 for derating values.

1.2 V LVCMOS (JESD8-12A)

Low-Voltage CMOS for 1.2 V complies with the LVCMOS standard JESD8-12A for general purpose 1.2 V applications. It uses a 1.2 V input buffer and a push-pull output buffer.

Table 2-63 • Minimum and Maximum DC Input and Output Levels

1.2 V LVCMOS Drive Strength	VIL		VIH		VOL	VOH	IOL	IOH	IOSL	IOSH	IIL ¹	IIH ²
	Min. V	Max. V	Min. V	Max. V	Max. V	Min. V	mA	mA	Max. mA ³	Max. mA ³	μA ⁴	μA ⁴
1 mA	-0.3	0.35 * VCCI	0.65 * VCCI	3.6	0.25 * VCCI	0.75 * VCCI	1	1	10	13	10	10

Notes:

1. I_{IL} is the input leakage current per I/O pin over recommended operating conditions where $-0.3 < V_{IN} < V_{IL}$.
2. I_{IH} is the input leakage current per I/O pin over recommended operating conditions where $V_{IH} < V_{IN} < V_{CCI}$. Input current is larger when operating outside recommended ranges.
3. Currents are measured at high temperature (100°C junction temperature) and maximum voltage.
4. Currents are measured at 85°C junction temperature.
5. Software default selection highlighted in gray.

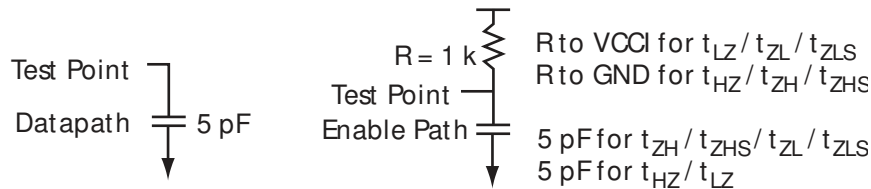

Figure 2-11 • AC Loading

Table 2-64 • 1.2 V LVCMOS AC Waveforms, Measuring Points, and Capacitive Loads

Input LOW (V)	Input HIGH (V)	Measuring Point* (V)	C _{LOAD} (pF)
0	1.2	0.6	5

Note: *Measuring point = V_{trip} . See Table 2-23 on page 2-20 for a complete table of trip points.

Timing Characteristics

Applies to 1.2 V DC Core Voltage

Table 2-65 • 1.2 V LVCMOS Low Slew

Commercial-Case Conditions: $T_J = 70^\circ\text{C}$, Worst-Case VCC = 1.14 V, Worst-Case VCCI = 1.14 V

Drive Strength	Speed Grade	t_{DOUT}	t_{DP}	t_{DIN}	t_{PY}	t_{PYS}	t_{EOUT}	t_{ZL}	t_{ZH}	t_{LZ}	t_{HZ}	Units
1 mA	STD	1.55	8.30	0.26	1.56	2.27	1.10	7.97	7.54	2.56	2.55	ns

Note: For specific junction temperature and voltage supply levels, refer to Table 2-6 on page 2-6 for derating values.

Table 2-66 • 1.2 V LVCMOS High Slew

Commercial-Case Conditions: $T_J = 70^\circ\text{C}$, Worst-Case VCC = 1.14 V, Worst-Case VCCI = 1.14 V

Drive Strength	Speed Grade	t_{DOUT}	t_{DP}	t_{DIN}	t_{PY}	t_{PYS}	t_{EOUT}	t_{ZL}	t_{ZH}	t_{LZ}	t_{HZ}	Units
1 mA	STD	1.55	3.50	0.26	1.56	2.27	1.10	3.37	3.10	2.55	2.66	ns

Note: For specific junction temperature and voltage supply levels, refer to Table 2-6 on page 2-6 for derating values.

1.2 V LVCMOS Wide Range

Table 2-67 • Minimum and Maximum DC Input and Output Levels

1.2 V LVCMOS Wide Range	VIL		VIH		VOL	VOH	IOL	IOH	IOSL	IOSH	IIL ¹	IIH ²
	Min. V	Max. V	Min. V	Max. V	Max. V	Min. V	mA	mA	Max. mA ³	Max. mA ³	μA ⁴	μA ⁴
1 mA	-0.3	0.3 * VCCI	0.7 * VCCI	3.6	0.1	VCCI - 0.1	100	100	10	13	10	10

Notes:

1. I_{IL} is the input leakage current per I/O pin over recommended operating conditions where $-0.3 < V_{IN} < V_{IL}$.
2. I_{IH} is the input leakage current per I/O pin over recommended operating conditions where $V_{IH} < V_{IN} < V_{CCI}$. Input current is larger when operating outside recommended ranges.
3. Currents are measured at high temperature (100°C junction temperature) and maximum voltage.
4. Currents are measured at 85°C junction temperature.
5. Applicable to IGLOO nano V2 devices operating at $V_{CCI} \geq V_{CC}$.
6. Software default selection highlighted in gray.

Timing Characteristics

Applies to 1.2 V DC Core Voltage

Table 2-68 • 1.2 V LVCMOS Wide Range Low Slew – Applies to 1.2 V DC Core Voltage
Commercial-Case Conditions: $T_J = 70^\circ\text{C}$, Worst-Case VCC = 1.14 V, Worst-Case VCCI = 1.14 V

Drive Strength	Equivalent Software Default Drive Strength Option ¹	Speed Grade	t _{DOUT}	t _{DP}	t _{DIN}	t _{PY}	t _{PYS}	t _{EOUT}	t _{ZL}	t _{ZH}	t _{LZ}	t _{HZ}	Units
100 μA	1 mA	STD	1.55	8.30	0.26	1.56	2.27	1.10	7.97	7.54	2.56	2.55	ns

Notes:

1. The minimum drive strength for any LVCMOS 1.2 V software configuration when run in wide range is $\pm 100 \mu\text{A}$. Drive strength displayed in the software is supported for normal range only. For a detailed I/V curve, refer to the IBIS models.
2. For specific junction temperature and voltage supply levels, refer to [Table 2-6 on page 2-6](#) for derating values.

Table 2-69 • 1.2 V LVCMOS Wide Range High Slew – Applies to 1.2 V DC Core Voltage
Commercial-Case Conditions: $T_J = 70^\circ\text{C}$, Worst-Case VCC = 1.14 V, Worst-Case VCCI = 1.14 V

Drive Strength	Equivalent Software Default Drive Strength Option ¹	Speed Grade	t _{DOUT}	t _{DP}	t _{DIN}	t _{PY}	t _{PYS}	t _{EOUT}	t _{ZL}	t _{ZH}	t _{LZ}	t _{HZ}	Units
100 μA	1 mA	STD	1.55	3.50	0.26	1.56	2.27	1.10	3.37	3.10	2.55	2.66	ns

Notes:

1. The minimum drive strength for any LVCMOS 1.2 V software configuration when run in wide range is $\pm 100 \mu\text{A}$. Drive strength displayed in the software is supported for normal range only. For a detailed I/V curve, refer to the IBIS models.
2. For specific junction temperature and voltage supply levels, refer to [Table 2-6 on page 2-6](#) for derating values.
3. Software default selection highlighted in gray.

I/O Register Specifications

Fully Registered I/O Buffers with Asynchronous Preset

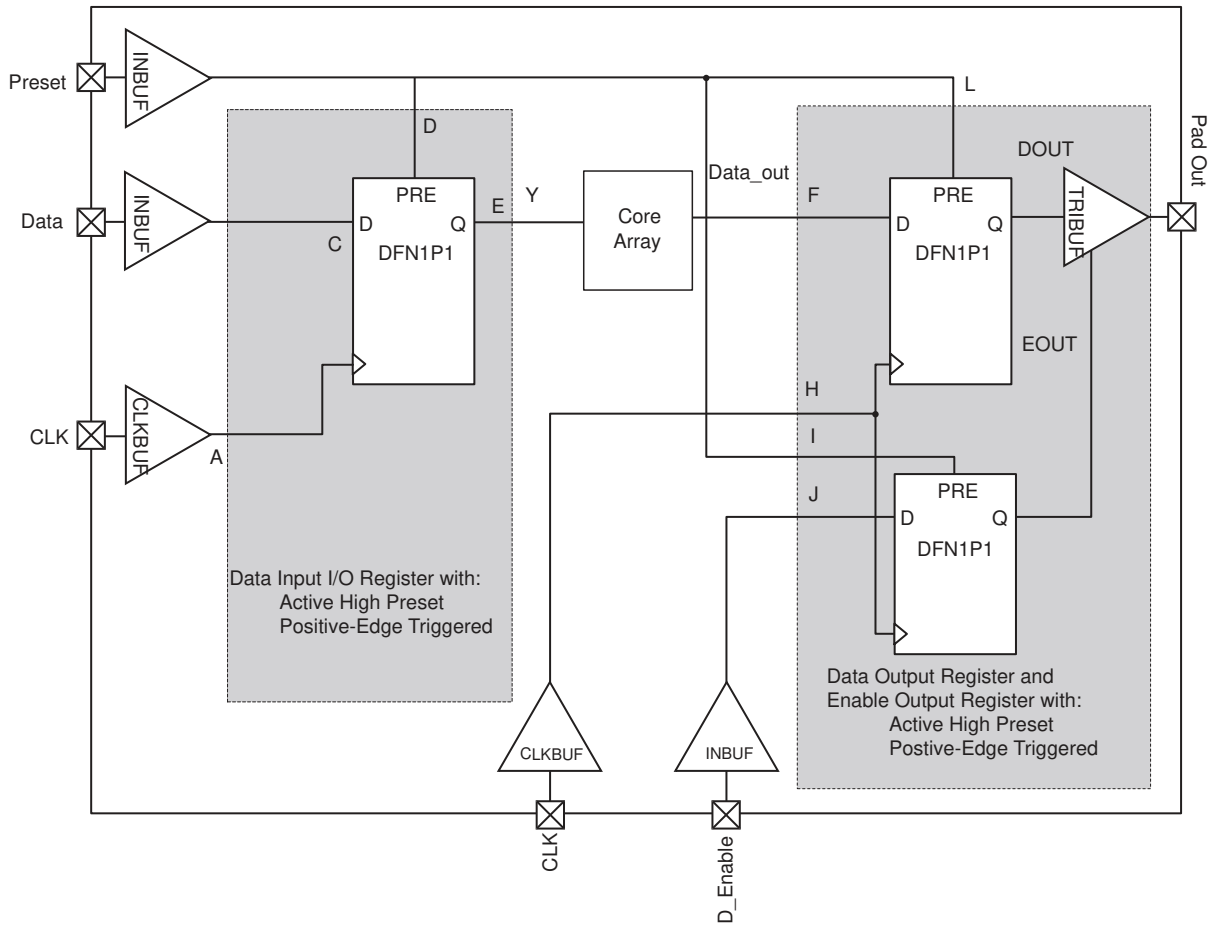

Figure 2-12 • Timing Model of Registered I/O Buffers with Asynchronous Preset

Table 2-70 • Parameter Definition and Measuring Nodes

Parameter Name	Parameter Definition	Measuring Nodes (from, to)*
t_{OCLKQ}	Clock-to-Q of the Output Data Register	H, DOUT
t_{OSUD}	Data Setup Time for the Output Data Register	F, H
t_{OHD}	Data Hold Time for the Output Data Register	F, H
t_{OPRE2Q}	Asynchronous Preset-to-Q of the Output Data Register	L, DOUT
$t_{OREMPRE}$	Asynchronous Preset Removal Time for the Output Data Register	L, H
$t_{ORECPRE}$	Asynchronous Preset Recovery Time for the Output Data Register	L, H
t_{OECLKQ}	Clock-to-Q of the Output Enable Register	H, EOUT
t_{OESUD}	Data Setup Time for the Output Enable Register	J, H
t_{OEHD}	Data Hold Time for the Output Enable Register	J, H
$t_{OEPRE2Q}$	Asynchronous Preset-to-Q of the Output Enable Register	I, EOUT
$t_{OEREMPRE}$	Asynchronous Preset Removal Time for the Output Enable Register	I, H
$t_{OERECPRE}$	Asynchronous Preset Recovery Time for the Output Enable Register	I, H
t_{ICLKQ}	Clock-to-Q of the Input Data Register	A, E
t_{ISUD}	Data Setup Time for the Input Data Register	C, A
t_{IHD}	Data Hold Time for the Input Data Register	C, A
t_{IPRE2Q}	Asynchronous Preset-to-Q of the Input Data Register	D, E
$t_{IREMPRE}$	Asynchronous Preset Removal Time for the Input Data Register	D, A
$t_{IRECPRE}$	Asynchronous Preset Recovery Time for the Input Data Register	D, A

Note: *See Figure 2-12 on page 2-41 for more information.

Table 2-71 • Parameter Definition and Measuring Nodes

Parameter Name	Parameter Definition	Measuring Nodes (from, to)*
t _{OCLKQ}	Clock-to-Q of the Output Data Register	HH, DOUT
t _{OSUD}	Data Setup Time for the Output Data Register	FF, HH
t _{OHD}	Data Hold Time for the Output Data Register	FF, HH
t _{OCLR2Q}	Asynchronous Clear-to-Q of the Output Data Register	LL, DOUT
t _{OREMCLR}	Asynchronous Clear Removal Time for the Output Data Register	LL, HH
t _{ORECCLR}	Asynchronous Clear Recovery Time for the Output Data Register	LL, HH
t _{OELCKQ}	Clock-to-Q of the Output Enable Register	HH, EOUT
t _{OESUD}	Data Setup Time for the Output Enable Register	JJ, HH
t _{OEHd}	Data Hold Time for the Output Enable Register	JJ, HH
t _{OELR2Q}	Asynchronous Clear-to-Q of the Output Enable Register	II, EOUT
t _{OEREMCLR}	Asynchronous Clear Removal Time for the Output Enable Register	II, HH
t _{OERECCLR}	Asynchronous Clear Recovery Time for the Output Enable Register	II, HH
t _{ICLKQ}	Clock-to-Q of the Input Data Register	AA, EE
t _{ISUD}	Data Setup Time for the Input Data Register	CC, AA
t _{IHD}	Data Hold Time for the Input Data Register	CC, AA
t _{ICLR2Q}	Asynchronous Clear-to-Q of the Input Data Register	DD, EE
t _{IREMCLR}	Asynchronous Clear Removal Time for the Input Data Register	DD, AA
t _{IRECCLR}	Asynchronous Clear Recovery Time for the Input Data Register	DD, AA

Note: *See Figure 2-13 on page 2-43 for more information.

Input Register

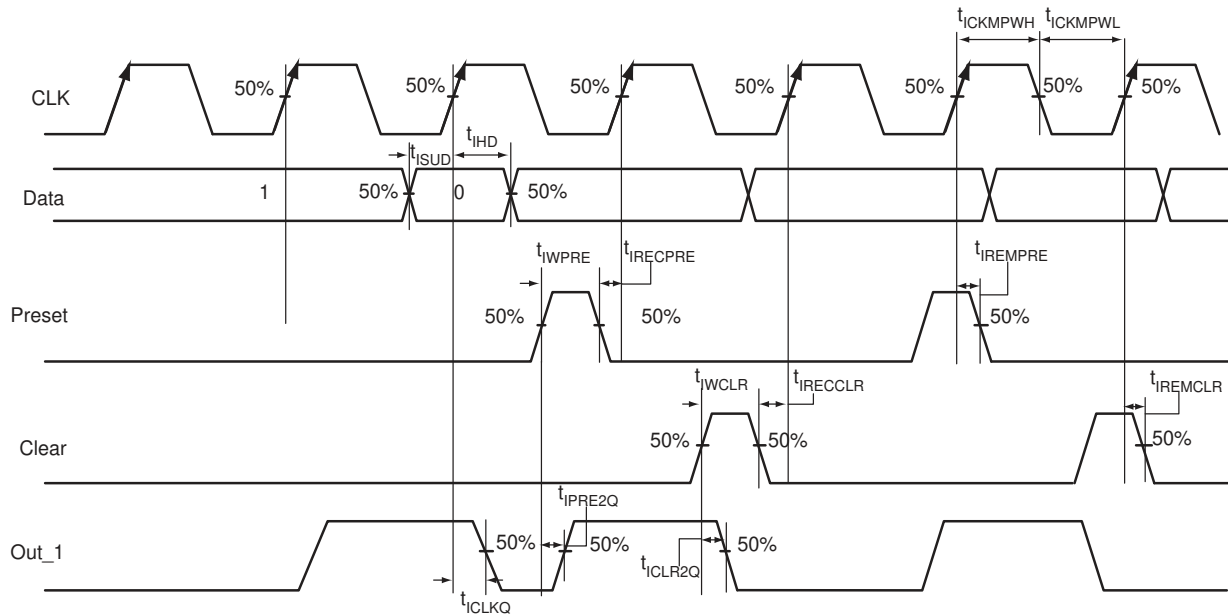

Figure 2-14 • Input Register Timing Diagram

Timing Characteristics

1.5 V DC Core Voltage

Table 2-72 • Input Data Register Propagation Delays
Commercial-Case Conditions: $T_J = 70^\circ\text{C}$, Worst-Case $V_{CC} = 1.425\text{ V}$

Parameter	Description	Std.	Units
t_{ICLKQ}	Clock-to-Q of the Input Data Register	0.42	ns
t_{ISUD}	Data Setup Time for the Input Data Register	0.47	ns
t_{IHD}	Data Hold Time for the Input Data Register	0.00	ns
t_{ICLR2Q}	Asynchronous Clear-to-Q of the Input Data Register	0.79	ns
t_{IPRE2Q}	Asynchronous Preset-to-Q of the Input Data Register	0.79	ns
t_{IREMCLR}	Asynchronous Clear Removal Time for the Input Data Register	0.00	ns
t_{IRECCLR}	Asynchronous Clear Recovery Time for the Input Data Register	0.24	ns
t_{IREMPRE}	Asynchronous Preset Removal Time for the Input Data Register	0.00	ns
t_{IRECPRE}	Asynchronous Preset Recovery Time for the Input Data Register	0.24	ns
t_{IWCLR}	Asynchronous Clear Minimum Pulse Width for the Input Data Register	0.19	ns
t_{IWPRE}	Asynchronous Preset Minimum Pulse Width for the Input Data Register	0.19	ns
t_{ICKMPWH}	Clock Minimum Pulse Width HIGH for the Input Data Register	0.31	ns
t_{ICKMPWL}	Clock Minimum Pulse Width LOW for the Input Data Register	0.28	ns

Note: For specific junction temperature and voltage supply levels, refer to [Table 2-6 on page 2-6](#) for derating values.

1.2 V DC Core Voltage

Table 2-73 • Input Data Register Propagation Delays
Commercial-Case Conditions: $T_J = 70^\circ\text{C}$, Worst-Case $V_{CC} = 1.14\text{ V}$

Parameter	Description	Std.	Units
t_{iCLKQ}	Clock-to-Q of the Input Data Register	0.68	ns
t_{iSUD}	Data Setup Time for the Input Data Register	0.97	ns
t_{iHD}	Data Hold Time for the Input Data Register	0.00	ns
t_{iCLR2Q}	Asynchronous Clear-to-Q of the Input Data Register	1.19	ns
t_{iPRE2Q}	Asynchronous Preset-to-Q of the Input Data Register	1.19	ns
$t_{iREMCLR}$	Asynchronous Clear Removal Time for the Input Data Register	0.00	ns
$t_{iRECCLR}$	Asynchronous Clear Recovery Time for the Input Data Register	0.24	ns
$t_{iREMPRE}$	Asynchronous Preset Removal Time for the Input Data Register	0.00	ns
$t_{iRECPRE}$	Asynchronous Preset Recovery Time for the Input Data Register	0.24	ns
t_{iWCLR}	Asynchronous Clear Minimum Pulse Width for the Input Data Register	0.19	ns
t_{iWPRE}	Asynchronous Preset Minimum Pulse Width for the Input Data Register	0.19	ns
$t_{iCKMPWH}$	Clock Minimum Pulse Width HIGH for the Input Data Register	0.31	ns
$t_{iCKMPWL}$	Clock Minimum Pulse Width LOW for the Input Data Register	0.28	ns

Note: For specific junction temperature and voltage supply levels, refer to [Table 2-7 on page 2-7](#) for derating values.

Output Register

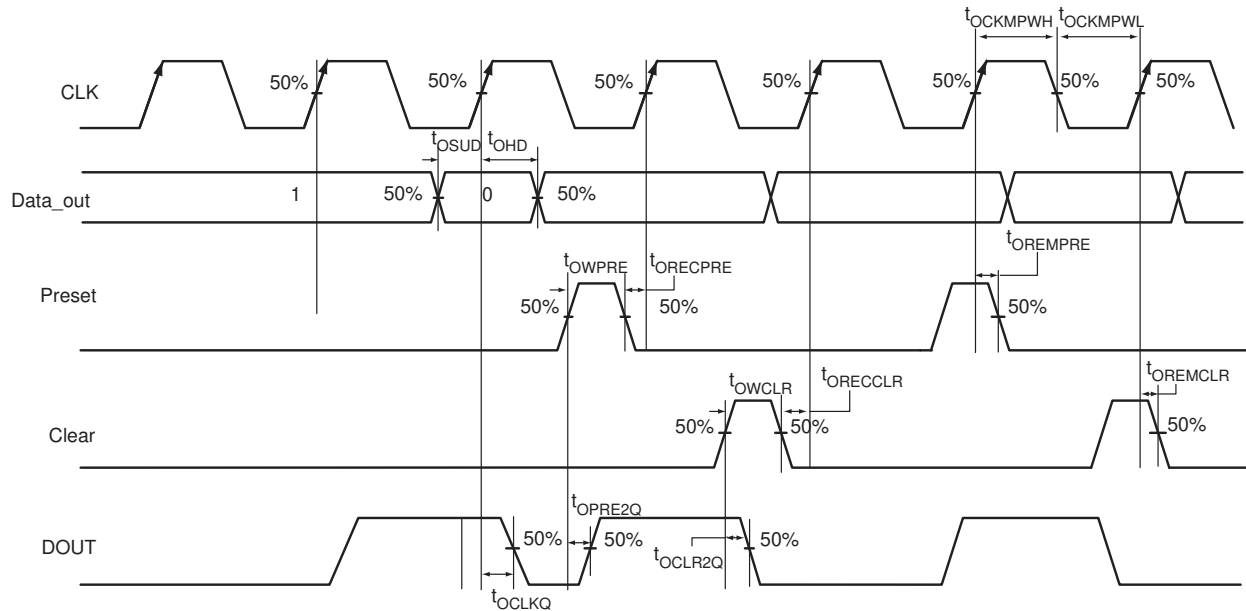

Figure 2-15 • Output Register Timing Diagram

Timing Characteristics

1.5 V DC Core Voltage

Table 2-74 • Output Data Register Propagation Delays
Commercial-Case Conditions: $T_J = 70^\circ\text{C}$, Worst-Case $V_{CC} = 1.425\text{ V}$

Parameter	Description	Std.	Units
t_{OCLKQ}	Clock-to-Q of the Output Data Register	1.00	ns
t_{OSUD}	Data Setup Time for the Output Data Register	0.51	ns
t_{OHD}	Data Hold Time for the Output Data Register	0.00	ns
t_{OCLR2Q}	Asynchronous Clear-to-Q of the Output Data Register	1.34	ns
t_{OPRE2Q}	Asynchronous Preset-to-Q of the Output Data Register	1.34	ns
t_{OEMCLR}	Asynchronous Clear Removal Time for the Output Data Register	0.00	ns
t_{ORECLL}	Asynchronous Clear Recovery Time for the Output Data Register	0.24	ns
$t_{OREMPRE}$	Asynchronous Preset Removal Time for the Output Data Register	0.00	ns
$t_{ORECPRE}$	Asynchronous Preset Recovery Time for the Output Data Register	0.24	ns
t_{OWCLR}	Asynchronous Clear Minimum Pulse Width for the Output Data Register	0.19	ns
t_{OWPRE}	Asynchronous Preset Minimum Pulse Width for the Output Data Register	0.19	ns
$t_{OCKMPWH}$	Clock Minimum Pulse Width HIGH for the Output Data Register	0.31	ns
$t_{OCKMPWL}$	Clock Minimum Pulse Width LOW for the Output Data Register	0.28	ns

Note: For specific junction temperature and voltage supply levels, refer to Table 2-6 on page 2-6 for derating values.

1.2 V DC Core Voltage
Table 2-75 • Output Data Register Propagation Delays
Commercial-Case Conditions: $T_J = 70^\circ\text{C}$, Worst-Case VCC = 1.14 V

Parameter	Description	Std.	Units
t_{OCLKQ}	Clock-to-Q of the Output Data Register	1.52	ns
t_{OSUD}	Data Setup Time for the Output Data Register	1.15	ns
t_{OHD}	Data Hold Time for the Output Data Register	0.00	ns
t_{OCLR2Q}	Asynchronous Clear-to-Q of the Output Data Register	1.96	ns
t_{OPRE2Q}	Asynchronous Preset-to-Q of the Output Data Register	1.96	ns
t_{OREMCLR}	Asynchronous Clear Removal Time for the Output Data Register	0.00	ns
t_{ORECCLR}	Asynchronous Clear Recovery Time for the Output Data Register	0.24	ns
t_{OREMPRE}	Asynchronous Preset Removal Time for the Output Data Register	0.00	ns
t_{ORECPRE}	Asynchronous Preset Recovery Time for the Output Data Register	0.24	ns
t_{OWCLR}	Asynchronous Clear Minimum Pulse Width for the Output Data Register	0.19	ns
t_{OWPRE}	Asynchronous Preset Minimum Pulse Width for the Output Data Register	0.19	ns
t_{OCKMPWH}	Clock Minimum Pulse Width HIGH for the Output Data Register	0.31	ns
t_{OCKMPWL}	Clock Minimum Pulse Width LOW for the Output Data Register	0.28	ns

Note: For specific junction temperature and voltage supply levels, refer to [Table 2-7 on page 2-7](#) for derating values.

Output Enable Register

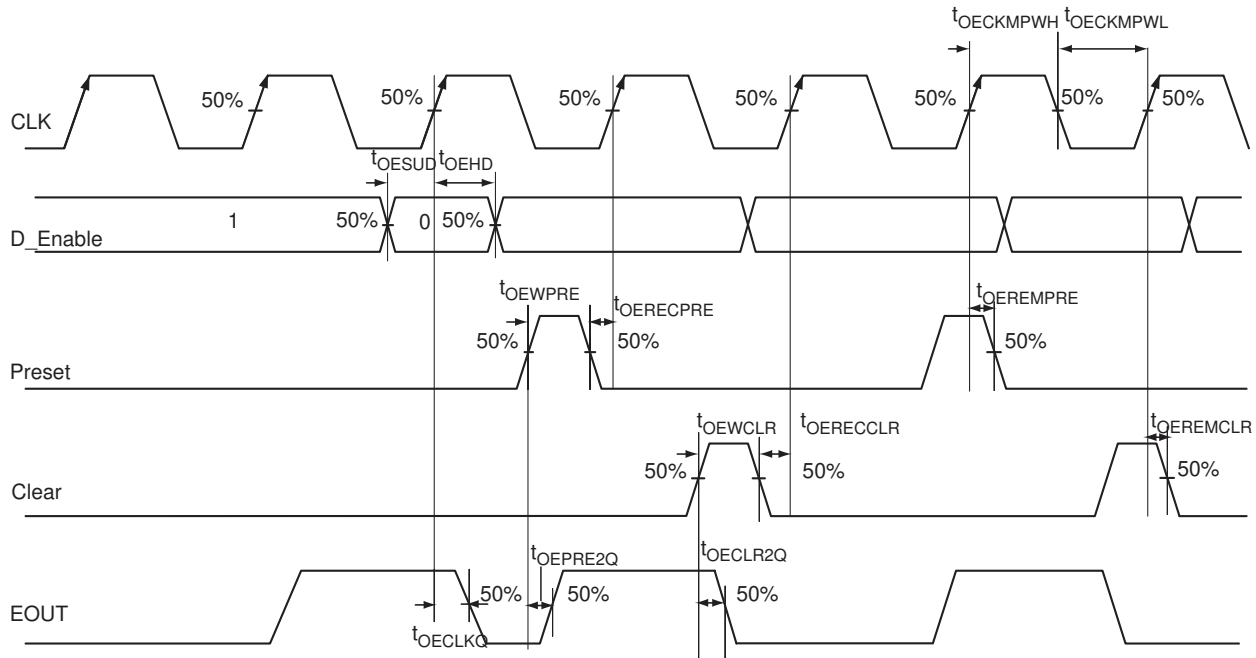

Figure 2-16 • Output Enable Register Timing Diagram

Timing Characteristics

1.5 V DC Core Voltage

Table 2-76 • Output Enable Register Propagation Delays
Commercial-Case Conditions: $T_J = 70^\circ\text{C}$, Worst-Case $V_{CC} = 1.425\text{ V}$

Parameter	Description	Std.	Units
t_{OECLKQ}	Clock-to-Q of the Output Enable Register	0.75	ns
t_{OESUD}	Data Setup Time for the Output Enable Register	0.51	ns
t_{OEHD}	Data Hold Time for the Output Enable Register	0.00	ns
$t_{OECLR2Q}$	Asynchronous Clear-to-Q of the Output Enable Register	1.13	ns
$t_{OEPRE2Q}$	Asynchronous Preset-to-Q of the Output Enable Register	1.13	ns
$t_{OEREMCLR}$	Asynchronous Clear Removal Time for the Output Enable Register	0.00	ns
$t_{OERECCLR}$	Asynchronous Clear Recovery Time for the Output Enable Register	0.24	ns
$t_{OEREMPRE}$	Asynchronous Preset Removal Time for the Output Enable Register	0.00	ns
$t_{OERECPRE}$	Asynchronous Preset Recovery Time for the Output Enable Register	0.24	ns
t_{OEWCLR}	Asynchronous Clear Minimum Pulse Width for the Output Enable Register	0.19	ns
t_{OEWPRE}	Asynchronous Preset Minimum Pulse Width for the Output Enable Register	0.19	ns
$t_{OECKMPWH}$	Clock Minimum Pulse Width HIGH for the Output Enable Register	0.31	ns
$t_{OECKMPWL}$	Clock Minimum Pulse Width LOW for the Output Enable Register	0.28	ns

Note: For specific junction temperature and voltage supply levels, refer to Table 2-6 on page 2-6 for derating values.

1.2 V DC Core Voltage

Table 2-77 • Output Enable Register Propagation Delays
Commercial-Case Conditions: $T_J = 70^\circ\text{C}$, Worst-Case $V_{CC} = 1.14\text{ V}$

Parameter	Description	Std.	Units
t_{OECLKQ}	Clock-to-Q of the Output Enable Register	1.10	ns
t_{OESUD}	Data Setup Time for the Output Enable Register	1.15	ns
t_{OEHD}	Data Hold Time for the Output Enable Register	0.00	ns
$t_{OECLR2Q}$	Asynchronous Clear-to-Q of the Output Enable Register	1.65	ns
$t_{OEPRE2Q}$	Asynchronous Preset-to-Q of the Output Enable Register	1.65	ns
$t_{OEREMCLR}$	Asynchronous Clear Removal Time for the Output Enable Register	0.00	ns
$t_{OERECCLR}$	Asynchronous Clear Recovery Time for the Output Enable Register	0.24	ns
$t_{OEREMPRE}$	Asynchronous Preset Removal Time for the Output Enable Register	0.00	ns
$t_{OERECPRE}$	Asynchronous Preset Recovery Time for the Output Enable Register	0.24	ns
$t_{OEWCCLR}$	Asynchronous Clear Minimum Pulse Width for the Output Enable Register	0.19	ns
$t_{OEWPRES}$	Asynchronous Preset Minimum Pulse Width for the Output Enable Register	0.19	ns
$t_{OECKMPWH}$	Clock Minimum Pulse Width HIGH for the Output Enable Register	0.31	ns
$t_{OECKMPWL}$	Clock Minimum Pulse Width LOW for the Output Enable Register	0.28	ns

Note: For specific junction temperature and voltage supply levels, refer to [Table 2-7 on page 2-7](#) for derating values.

DDR Module Specifications

Note: DDR is not supported for AGLN010 and AGLN020 devices.

Input DDR Module

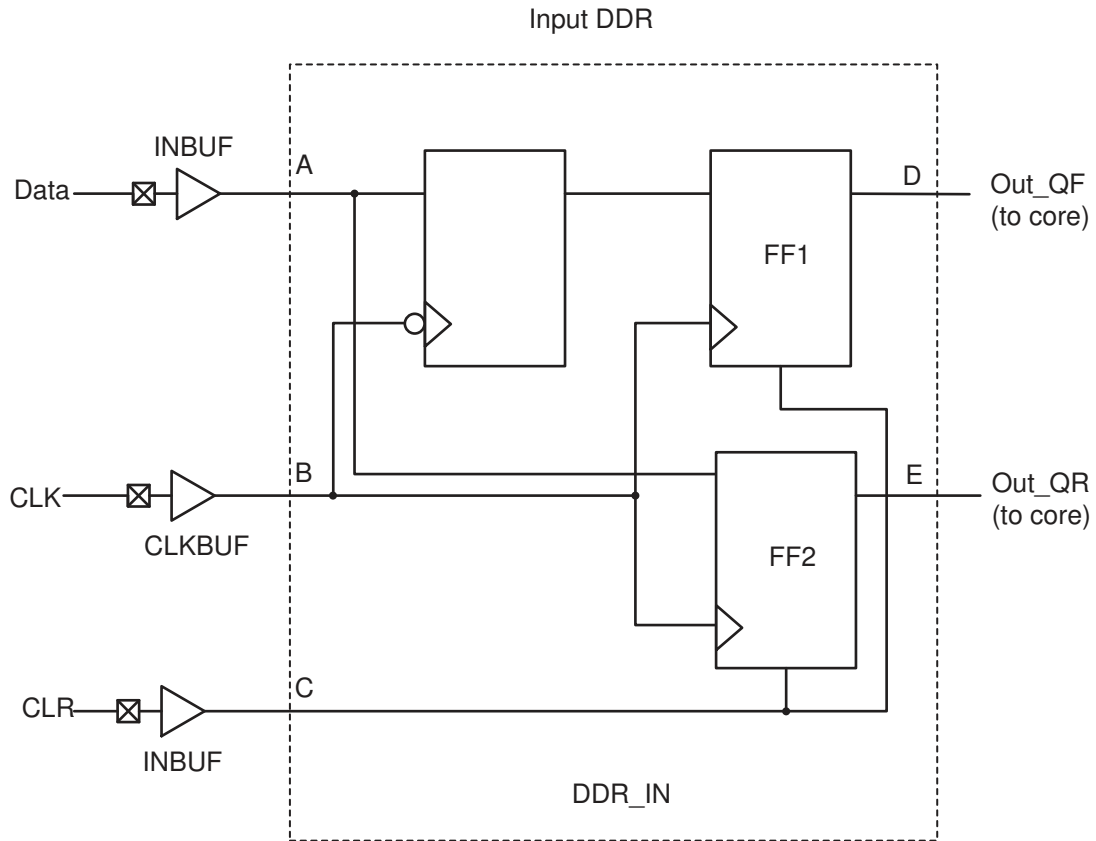

Figure 2-17 • Input DDR Timing Model

Table 2-78 • Parameter Definitions

Parameter Name	Parameter Definition	Measuring Nodes (from, to)
t_{DDRICKQ1}	Clock-to-Out Out_QR	B, D
t_{DDRICKQ2}	Clock-to-Out Out_QF	B, E
t_{DDRISUD}	Data Setup Time of DDR input	A, B
t_{DDRIHD}	Data Hold Time of DDR input	A, B
$t_{\text{DDRICLR2Q1}}$	Clear-to-Out Out_QR	C, D
$t_{\text{DDRICLR2Q2}}$	Clear-to-Out Out_QF	C, E
$t_{\text{DDRIREMCLR}}$	Clear Removal	C, B
$t_{\text{DDRIRECCLR}}$	Clear Recovery	C, B

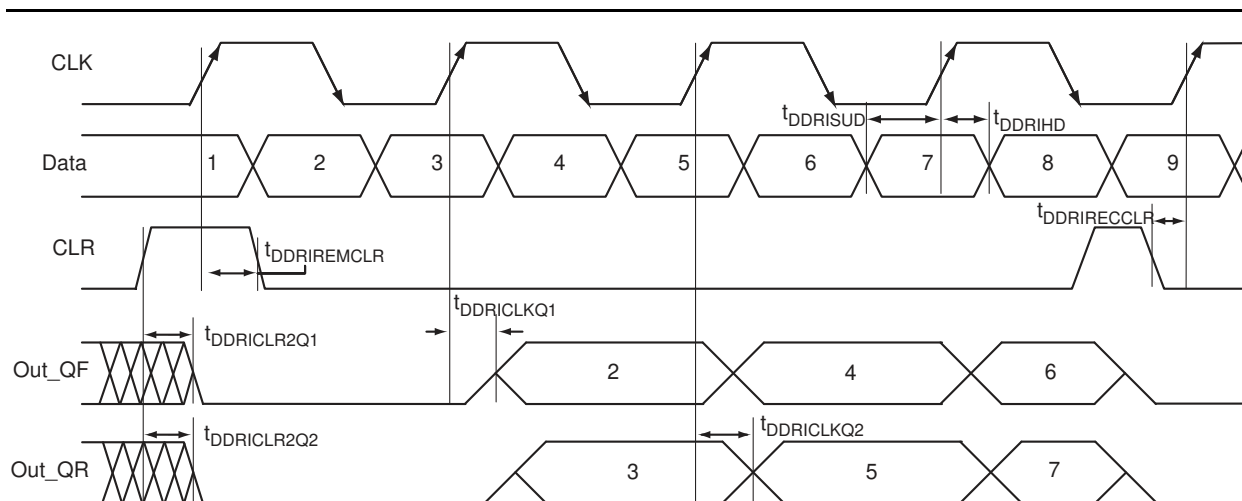

Figure 2-18 • Input DDR Timing Diagram

Timing Characteristics

1.5 V DC Core Voltage

Table 2-79 • Input DDR Propagation Delays
Commercial-Case Conditions: $T_J = 70^\circ\text{C}$, Worst-Case $V_{CC} = 1.25\text{ V}$

Parameter	Description	Std.	Units
$t_{DDRICKQ1}$	Clock-to-Out Out_QR for Input DDR	0.48	ns
$t_{DDRICKQ2}$	Clock-to-Out Out_QF for Input DDR	0.65	ns
$t_{DDRISUD1}$	Data Setup for Input DDR (negedge)	0.50	ns
$t_{DDRISUD2}$	Data Setup for Input DDR (posedge)	0.40	ns
$t_{DDRIHD1}$	Data Hold for Input DDR (negedge)	0.00	ns
$t_{DDRIHD2}$	Data Hold for Input DDR (posedge)	0.00	ns
$t_{DDRICLR2Q1}$	Asynchronous Clear-to-Out Out_QR for Input DDR	0.82	ns
$t_{DDRICLR2Q2}$	Asynchronous Clear-to-Out Out_QF for Input DDR	0.98	ns
$t_{DDRIREMCLR}$	Asynchronous Clear Removal Time for Input DDR	0.00	ns
$t_{DDRIRECCLR}$	Asynchronous Clear Recovery Time for Input DDR	0.23	ns
$t_{DDRIWCLR}$	Asynchronous Clear Minimum Pulse Width for Input DDR	0.19	ns
$t_{DDRICKMPWH}$	Clock Minimum Pulse Width HIGH for Input DDR	0.31	ns
$t_{DDRICKMPWL}$	Clock Minimum Pulse Width LOW for Input DDR	0.28	ns
$F_{DDRIMAX}$	Maximum Frequency for Input DDR	250.00	MHz

Note: For specific junction temperature and voltage supply levels, refer to [Table 2-7](#) on page 2-7 for derating values.

1.2 V DC Core Voltage

Table 2-80 • Input DDR Propagation Delays
Commercial-Case Conditions: $T_J = 70^\circ\text{C}$, Worst-Case $V_{CC} = 1.14\text{ V}$

Parameter	Description	Std.	Units
t_{DDRCLKQ1}	Clock-to-Out Out_QR for Input DDR	0.76	ns
t_{DDRCLKQ2}	Clock-to-Out Out_QF for Input DDR	0.94	ns
t_{DDRISUD1}	Data Setup for Input DDR (negedge)	0.93	ns
t_{DDRISUD2}	Data Setup for Input DDR (posedge)	0.84	ns
t_{DDRiHD1}	Data Hold for Input DDR (negedge)	0.00	ns
t_{DDRiHD2}	Data Hold for Input DDR (posedge)	0.00	ns
$t_{\text{DDRiCLR2Q1}}$	Asynchronous Clear-to-Out Out_QR for Input DDR	1.23	ns
$t_{\text{DDRiCLR2Q2}}$	Asynchronous Clear-to-Out Out_QF for Input DDR	1.42	ns
$t_{\text{DDRiREMCLR}}$	Asynchronous Clear Removal Time for Input DDR	0.00	ns
$t_{\text{DDRiRECCLR}}$	Asynchronous Clear Recovery Time for Input DDR	0.24	ns
t_{DDRiWCLR}	Asynchronous Clear Minimum Pulse Width for Input DDR	0.19	ns
$t_{\text{DDRICKMPWH}}$	Clock Minimum Pulse Width HIGH for Input DDR	0.31	ns
$t_{\text{DDRICKMPWL}}$	Clock Minimum Pulse Width LOW for Input DDR	0.28	ns
F_{DDRIMAX}	Maximum Frequency for Input DDR	160.00	MHz

Note: For specific junction temperature and voltage supply levels, refer to [Table 2-7 on page 2-7](#) for derating values.

Output DDR Module

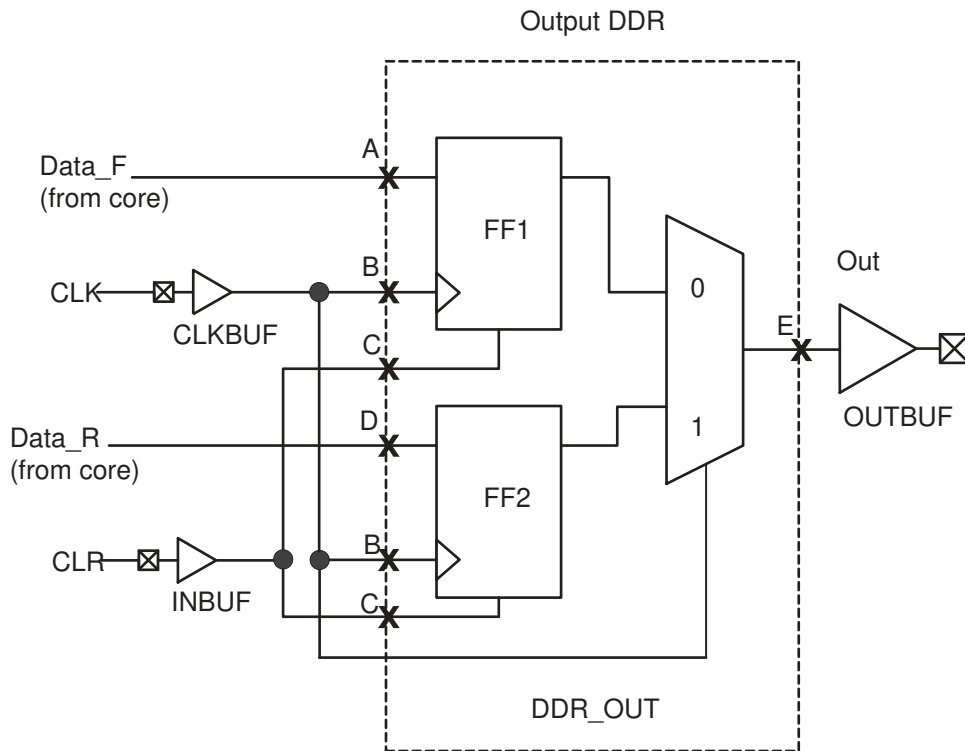
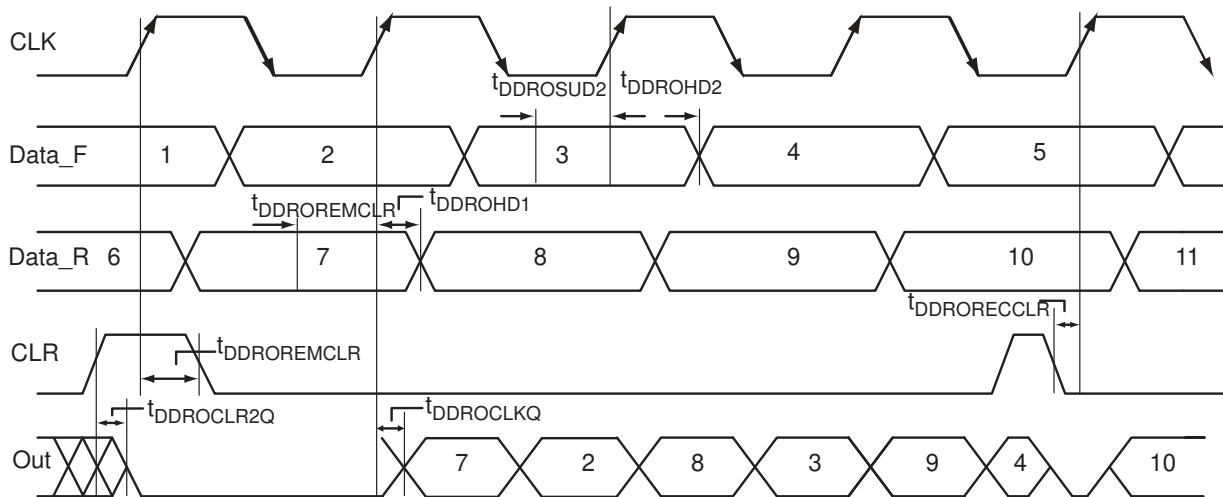

Figure 2-19 • Output DDR Timing Model

Table 2-81 • Parameter Definitions

Parameter Name	Parameter Definition	Measuring Nodes (from, to)
$t_{DDROCLKQ}$	Clock-to-Out	B, E
$t_{DDROCLR2Q}$	Asynchronous Clear-to-Out	C, E
$t_{DDROREMCLR}$	Clear Removal	C, B
$t_{DDRORECCLR}$	Clear Recovery	C, B
$t_{DDROSUD1}$	Data Setup Data_F	A, B
$t_{DDROSUD2}$	Data Setup Data_R	D, B
$t_{DDROHD1}$	Data Hold Data_F	A, B
$t_{DDROHD2}$	Data Hold Data_R	D, B

Figure 2-20 • Output DDR Timing Diagram

Timing Characteristics

1.5 V DC Core Voltage

Table 2-82 • Output DDR Propagation Delays
Commercial-Case Conditions: $T_J = 70^\circ\text{C}$, Worst-Case $V_{CC} = 1.425\text{ V}$

Parameter	Description	Std.	Units
t_{DDROCLKQ}	Clock-to-Out of DDR for Output DDR	1.07	ns
t_{DDROSUD1}	Data_F Data Setup for Output DDR	0.67	ns
t_{DDROSUD2}	Data_R Data Setup for Output DDR	0.67	ns
t_{DDROHD1}	Data_F Data Hold for Output DDR	0.00	ns
t_{DDROHD2}	Data_R Data Hold for Output DDR	0.00	ns
$t_{\text{DDROCLR2Q}}$	Asynchronous Clear-to-Out for Output DDR	1.38	ns
$t_{\text{DDROEMCLR}}$	Asynchronous Clear Removal Time for Output DDR	0.00	ns
$t_{\text{DDROECCLR}}$	Asynchronous Clear Recovery Time for Output DDR	0.23	ns
$t_{\text{DDROWCLR1}}$	Asynchronous Clear Minimum Pulse Width for Output DDR	0.19	ns
$t_{\text{DDROCKMPWH}}$	Clock Minimum Pulse Width HIGH for the Output DDR	0.31	ns
$t_{\text{DDROCKMPWL}}$	Clock Minimum Pulse Width LOW for the Output DDR	0.28	ns
F_{DDOMAX}	Maximum Frequency for the Output DDR	250.00	MHz

Note: For specific junction temperature and voltage supply levels, refer to [Table 2-6 on page 2-6](#) for derating values.

1.2 V DC Core Voltage
Table 2-83 • Output DDR Propagation Delays
Commercial-Case Conditions: $T_J = 70^\circ\text{C}$, Worst-Case $V_{CC} = 1.14\text{ V}$

Parameter	Description	Std.	Units
t_{DDROCLKQ}	Clock-to-Out of DDR for Output DDR	1.60	ns
t_{DDROSUD1}	Data_F Data Setup for Output DDR	1.09	ns
t_{DDROSUD2}	Data_R Data Setup for Output DDR	1.16	ns
t_{DDROHD1}	Data_F Data Hold for Output DDR	0.00	ns
t_{DDROHD2}	Data_R Data Hold for Output DDR	0.00	ns
$t_{\text{DDROCLR2Q}}$	Asynchronous Clear-to-Out for Output DDR	1.99	ns
$t_{\text{DDROREMCLR}}$	Asynchronous Clear Removal Time for Output DDR	0.00	ns
$t_{\text{DDRORECCLR}}$	Asynchronous Clear Recovery Time for Output DDR	0.24	ns
$t_{\text{DDROWCLR1}}$	Asynchronous Clear Minimum Pulse Width for Output DDR	0.19	ns
$t_{\text{DDROCKMPWH}}$	Clock Minimum Pulse Width HIGH for the Output DDR	0.31	ns
$t_{\text{DDROCKMPWL}}$	Clock Minimum Pulse Width LOW for the Output DDR	0.28	ns
F_{DDOMAX}	Maximum Frequency for the Output DDR	160.00	MHz

Note: For specific junction temperature and voltage supply levels, refer to [Table 2-7 on page 2-7](#) for derating values.

VersaTile Characteristics

VersaTile Specifications as a Combinatorial Module

The IGLOO nano library offers all combinations of LUT-3 combinatorial functions. In this section, timing characteristics are presented for a sample of the library. For more details, refer to the *IGLOO, ProASIC3, SmartFusion and Fusion Macro Library Guide for Software v10.1*.

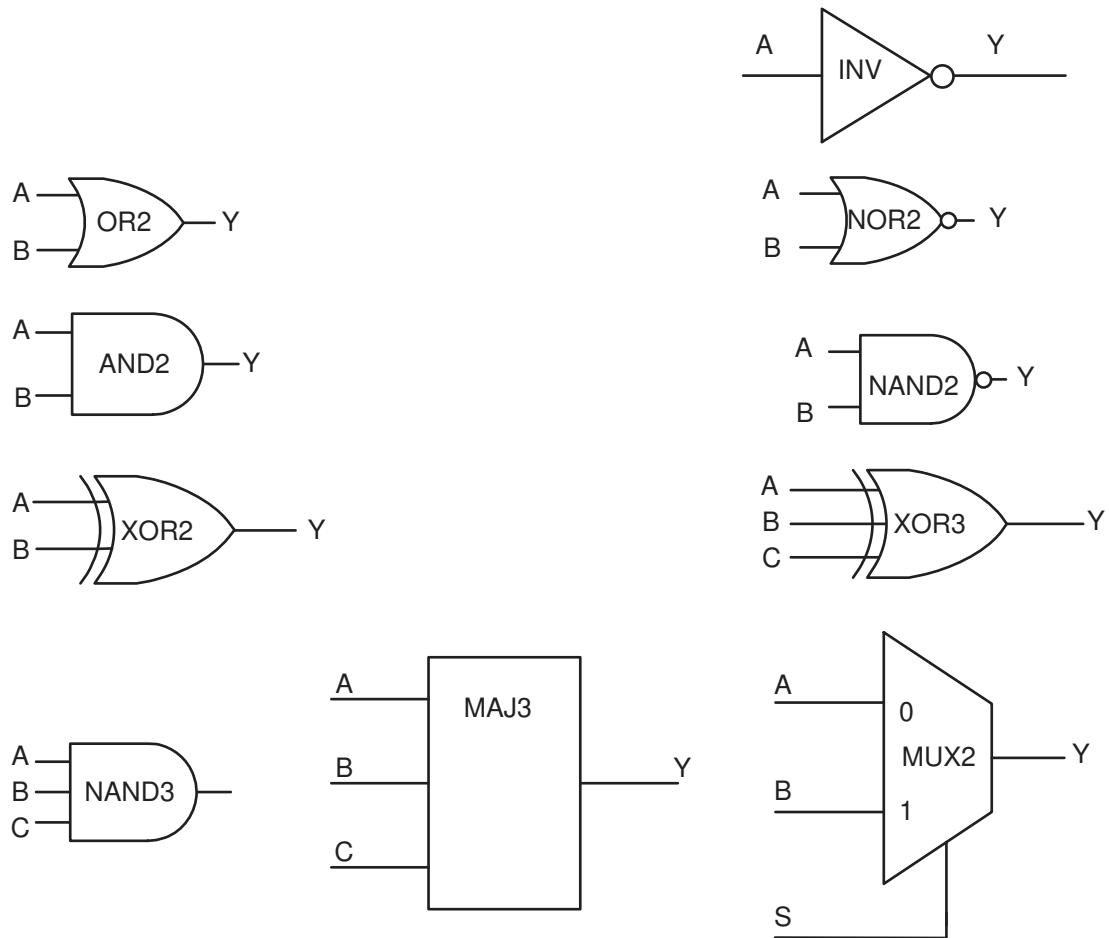

Figure 2-21 • Sample of Combinatorial Cells

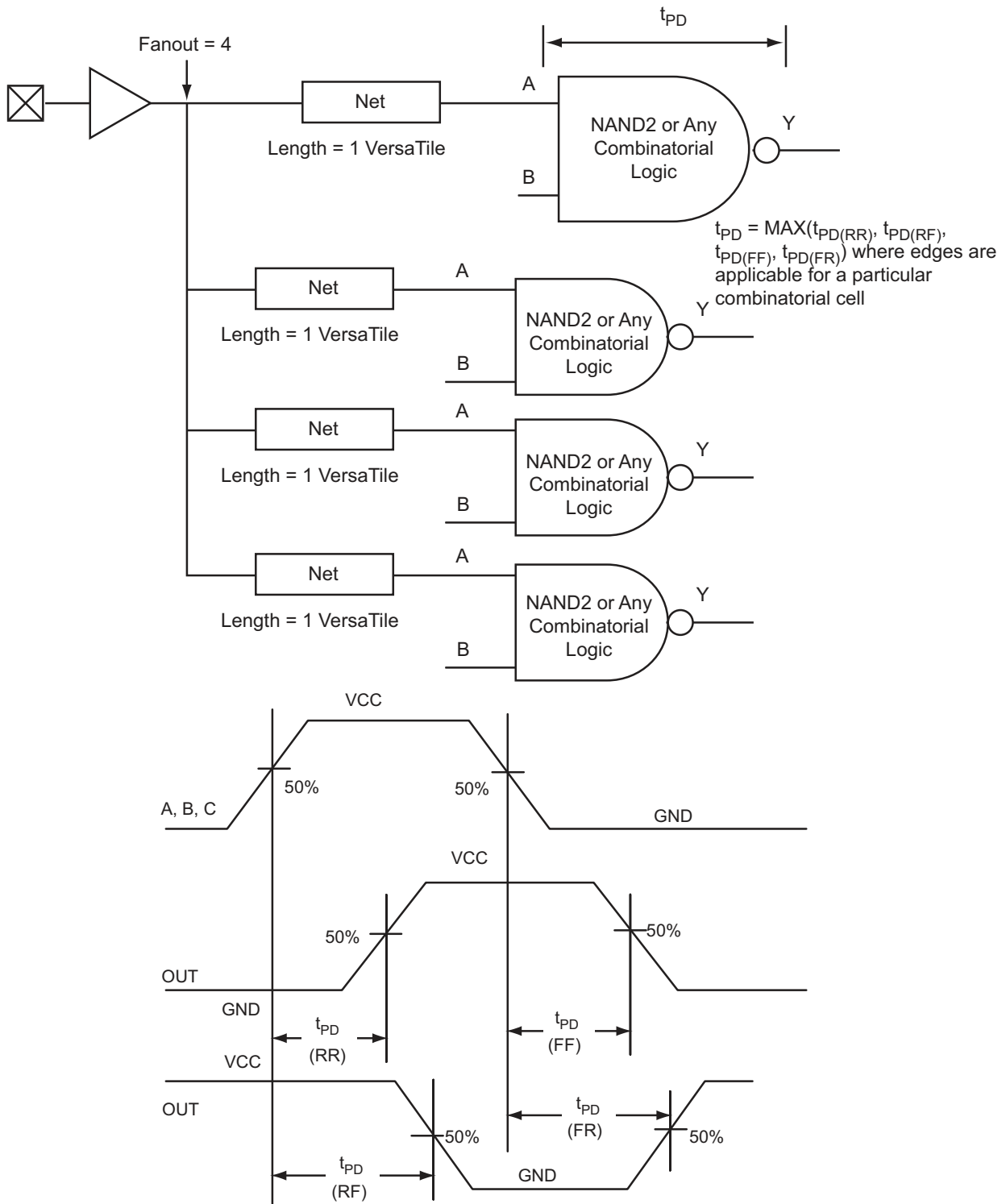

Figure 2-22 • Timing Model and Waveforms

Timing Characteristics

1.5 V DC Core Voltage

Table 2-84 • Combinatorial Cell Propagation Delays
Commercial-Case Conditions: $T_J = 70^\circ\text{C}$, Worst-Case $V_{CC} = 1.425\text{ V}$

Combinatorial Cell	Equation	Parameter	Std.	Units
INV	$Y = !A$	t_{PD}	0.76	ns
AND2	$Y = A \cdot B$	t_{PD}	0.87	ns
NAND2	$Y = !(A \cdot B)$	t_{PD}	0.91	ns
OR2	$Y = A + B$	t_{PD}	0.90	ns
NOR2	$Y = !(A + B)$	t_{PD}	0.94	ns
XOR2	$Y = A \oplus B$	t_{PD}	1.39	ns
MAJ3	$Y = \text{MAJ}(A, B, C)$	t_{PD}	1.44	ns
XOR3	$Y = A \oplus B \oplus C$	t_{PD}	1.60	ns
MUX2	$Y = A !S + B S$	t_{PD}	1.17	ns
AND3	$Y = A \cdot B \cdot C$	t_{PD}	1.18	ns

Note: For specific junction temperature and voltage supply levels, refer to [Table 2-6 on page 2-6](#) for derating values.

1.2 V DC Core Voltage

Table 2-85 • Combinatorial Cell Propagation Delays
Commercial-Case Conditions: $T_J = 70^\circ\text{C}$, Worst-Case $V_{CC} = 1.14\text{ V}$

Combinatorial Cell	Equation	Parameter	Std.	Units
INV	$Y = !A$	t_{PD}	1.33	ns
AND2	$Y = A \cdot B$	t_{PD}	1.48	ns
NAND2	$Y = !(A \cdot B)$	t_{PD}	1.58	ns
OR2	$Y = A + B$	t_{PD}	1.53	ns
NOR2	$Y = !(A + B)$	t_{PD}	1.63	ns
XOR2	$Y = A \oplus B$	t_{PD}	2.34	ns
MAJ3	$Y = \text{MAJ}(A, B, C)$	t_{PD}	2.59	ns
XOR3	$Y = A \oplus B \oplus C$	t_{PD}	2.74	ns
MUX2	$Y = A !S + B S$	t_{PD}	2.03	ns
AND3	$Y = A \cdot B \cdot C$	t_{PD}	2.11	ns

Note: For specific junction temperature and voltage supply levels, refer to [Table 2-7 on page 2-7](#) for derating values.

VersaTile Specifications as a Sequential Module

The IGLOO nano library offers a wide variety of sequential cells, including flip-flops and latches. Each has a data input and optional enable, clear, or preset. In this section, timing characteristics are presented for a representative sample from the library. For more details, refer to the *IGLOO, ProASIC3, SmartFusion and Fusion Macro Library Guide for Software v10.1*.

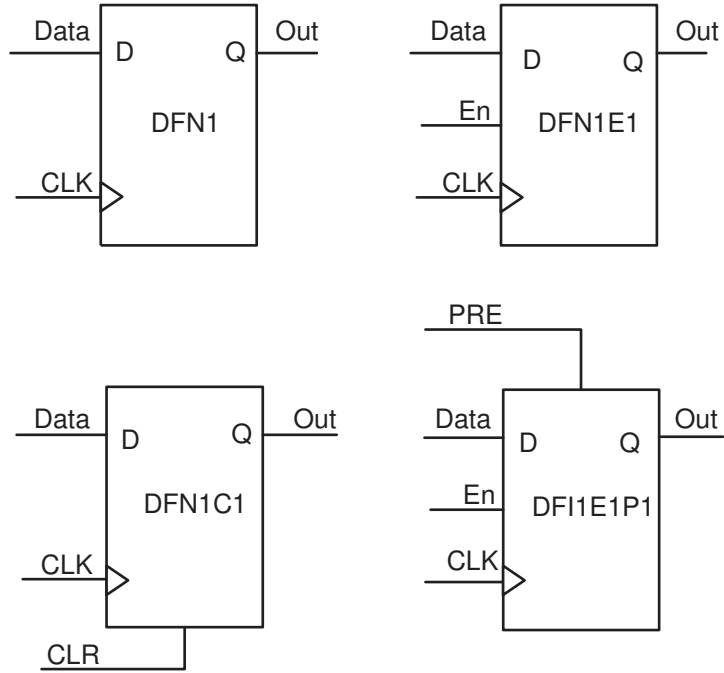

Figure 2-23 • Sample of Sequential Cells

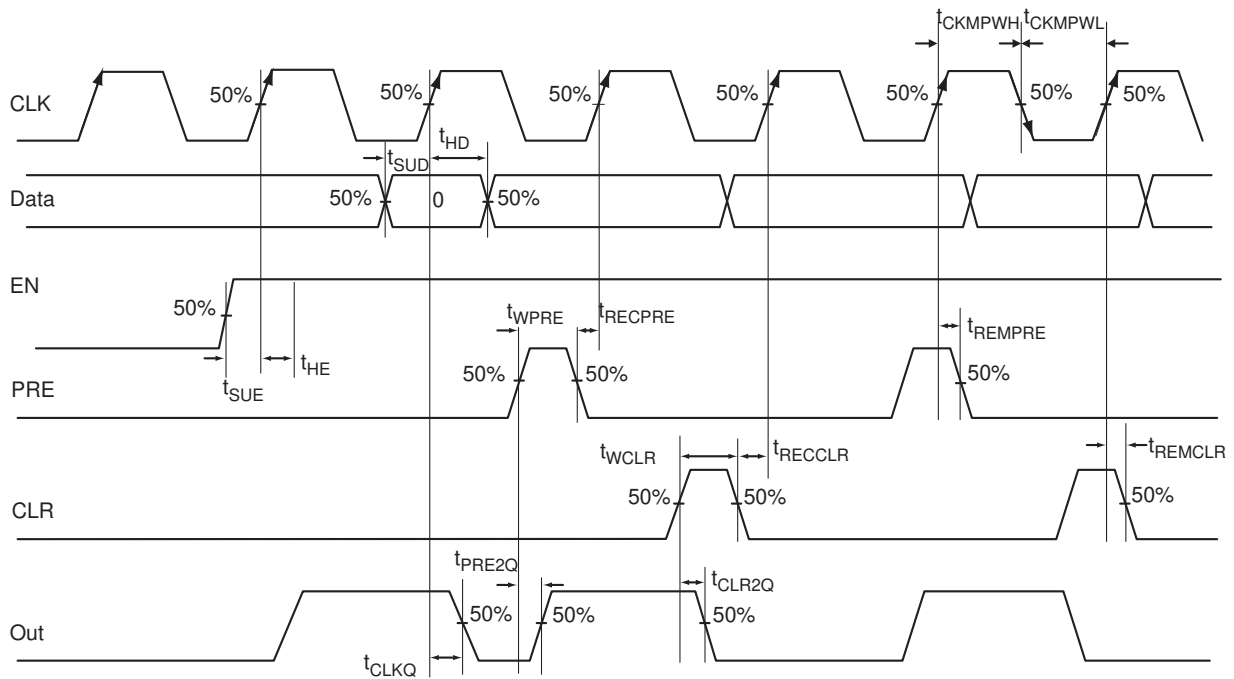

Figure 2-24 • Timing Model and Waveforms

Timing Characteristics

1.5 V DC Core Voltage

Table 2-86 • Register Delays

Commercial-Case Conditions: $T_j = 70^\circ\text{C}$, Worst-Case $V_{CC} = 1.425\text{ V}$

Parameter	Description	Std.	Units
t_{CLKQ}	Clock-to-Q of the Core Register	0.89	ns
t_{SUD}	Data Setup Time for the Core Register	0.81	ns
t_{HD}	Data Hold Time for the Core Register	0.00	ns
t_{SUE}	Enable Setup Time for the Core Register	0.73	ns
t_{HE}	Enable Hold Time for the Core Register	0.00	ns
t_{CLR2Q}	Asynchronous Clear-to-Q of the Core Register	0.60	ns
t_{PRE2Q}	Asynchronous Preset-to-Q of the Core Register	0.62	ns
t_{REMCLR}	Asynchronous Clear Removal Time for the Core Register	0.00	ns
t_{RECCLR}	Asynchronous Clear Recovery Time for the Core Register	0.24	ns
t_{REMPRE}	Asynchronous Preset Removal Time for the Core Register	0.00	ns
t_{RECPRE}	Asynchronous Preset Recovery Time for the Core Register	0.23	ns
t_{WCLR}	Asynchronous Clear Minimum Pulse Width for the Core Register	0.30	ns
t_{WPRE}	Asynchronous Preset Minimum Pulse Width for the Core Register	0.30	ns
t_{CKMPWH}	Clock Minimum Pulse Width HIGH for the Core Register	0.56	ns
t_{CKMPWL}	Clock Minimum Pulse Width LOW for the Core Register	0.56	ns

Note: For specific junction temperature and voltage supply levels, refer to Table 2-6 on page 2-6 for derating values.

1.2 V DC Core Voltage

Table 2-87 • Register Delays
Commercial-Case Conditions: $T_J = 70^\circ\text{C}$, Worst-Case $V_{CC} = 1.14\text{ V}$

Parameter	Description	Std.	Units
t_{CLKQ}	Clock-to-Q of the Core Register	1.61	ns
t_{SUD}	Data Setup Time for the Core Register	1.17	ns
t_{HD}	Data Hold Time for the Core Register	0.00	ns
t_{SUE}	Enable Setup Time for the Core Register	1.29	ns
t_{HE}	Enable Hold Time for the Core Register	0.00	ns
t_{CLR2Q}	Asynchronous Clear-to-Q of the Core Register	0.87	ns
t_{PRE2Q}	Asynchronous Preset-to-Q of the Core Register	0.89	ns
t_{REMCLR}	Asynchronous Clear Removal Time for the Core Register	0.00	ns
t_{RECCLR}	Asynchronous Clear Recovery Time for the Core Register	0.24	ns
t_{REMPRE}	Asynchronous Preset Removal Time for the Core Register	0.00	ns
t_{RECPRE}	Asynchronous Preset Recovery Time for the Core Register	0.24	ns
t_{WCLR}	Asynchronous Clear Minimum Pulse Width for the Core Register	0.46	ns
t_{WPRE}	Asynchronous Preset Minimum Pulse Width for the Core Register	0.46	ns
t_{CKMPWH}	Clock Minimum Pulse Width HIGH for the Core Register	0.95	ns
t_{CKMPWL}	Clock Minimum Pulse Width LOW for the Core Register	0.95	ns

Note: For specific junction temperature and voltage supply levels, refer to [Table 2-7 on page 2-7](#) for derating values.

Global Resource Characteristics

AGLN125 Clock Tree Topology

Clock delays are device-specific. Figure 2-25 is an example of a global tree used for clock routing. The global tree presented in Figure 2-25 is driven by a CCC located on the west side of the AGLN125 device. It is used to drive all D-flip-flops in the device.

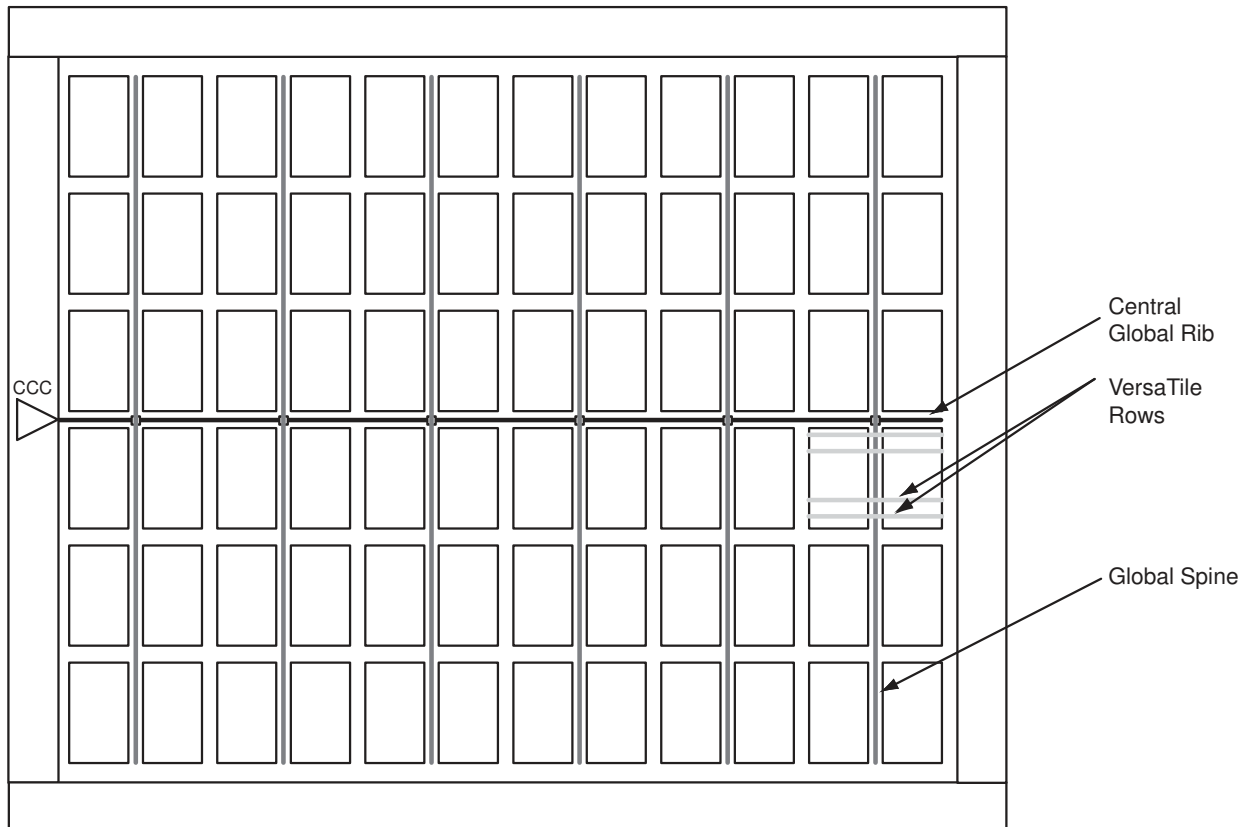

Figure 2-25 • Example of Global Tree Use in an AGLN125 Device for Clock Routing

Global Tree Timing Characteristics

Global clock delays include the central rib delay, the spine delay, and the row delay. Delays do not include I/O input buffer clock delays, as these are I/O standard-dependent, and the clock may be driven and conditioned internally by the CCC module. For more details on clock conditioning capabilities, refer to the "Clock Conditioning Circuits" section on page 2-70. Table 2-88 to Table 2-95 on page 2-68 present minimum and maximum global clock delays within each device. Minimum and maximum delays are measured with minimum and maximum loading.

Timing Characteristics

1.5 V DC Core Voltage

Table 2-88 • AGLN010 Global Resource
Commercial-Case Conditions: $T_J = 70^\circ\text{C}$, $V_{CC} = 1.425\text{ V}$

Parameter	Description	Std.		Units
		Min. ¹	Max. ²	
t_{RCKL}	Input Low Delay for Global Clock	1.13	1.42	ns
t_{RCKH}	Input High Delay for Global Clock	1.15	1.50	ns
$t_{RCKMPWH}$	Minimum Pulse Width HIGH for Global Clock	1.40		ns
$t_{RCKMPWL}$	Minimum Pulse Width LOW for Global Clock	1.65		ns
t_{RCKSW}	Maximum Skew for Global Clock		0.35	ns

Notes:

- Value reflects minimum load. The delay is measured from the CCC output to the clock pin of a sequential element, located in a lightly loaded row (single element is connected to the global net).
- Value reflects maximum load. The delay is measured on the clock pin of the farthest sequential element, located in a fully loaded row (all available flip-flops are connected to the global net in the row).
- For specific junction temperature and voltage supply levels, refer to Table 2-6 on page 2-6 for derating values.

Table 2-89 • AGLN015 Global Resource
Commercial-Case Conditions: $T_J = 70^\circ\text{C}$, $V_{CC} = 1.425\text{ V}$

Units
ns
ns
ns
ns
ns

Table 2-90 • AGLN020 Global Resource
Commercial-Case Conditions: $T_J = 70^\circ\text{C}$, $V_{CC} = 1.425\text{ V}$

Parameter	Description	Std.		Units
		Min. ¹	Max. ²	
t_{RCKL}	Input Low Delay for Global Clock	1.21	1.55	ns
t_{RCKH}	Input High Delay for Global Clock	1.23	1.65	ns
$t_{RCKMPWH}$	Minimum Pulse Width High for Global Clock	1.40		ns
$t_{RCKMPWL}$	Minimum Pulse Width Low for Global Clock	1.65		ns

Table 2-90 • AGLN020 Global Resource
Commercial-Case Conditions: $T_J = 70^\circ\text{C}$, $V_{CC} = 1.425\text{ V}$

Parameter	Description	Std.		Units
		Min. ¹	Max. ²	
t_{RCKSW}	Maximum Skew for Global Clock		0.42	ns

Notes:

1. Value reflects minimum load. The delay is measured from the CCC output to the clock pin of a sequential element, located in a lightly loaded row (single element is connected to the global net).
2. Value reflects maximum load. The delay is measured on the clock pin of the farthest sequential element, located in a fully loaded row (all available flip-flops are connected to the global net in the row).
3. For specific junction temperature and voltage supply levels, refer to [Table 2-6 on page 2-6](#) for derating values.

Table 2-91 • AGLN060 Global Resource
Commercial-Case Conditions: $T_J = 70^\circ\text{C}$, $V_{CC} = 1.425\text{ V}$

Parameter	Description	Std.		Units
		Min. ¹	Max. ²	
t_{RCKL}	Input Low Delay for Global Clock	1.32	1.62	ns
t_{RCKH}	Input High Delay for Global Clock	1.34	1.71	ns
$t_{RCKMPWH}$	Minimum Pulse Width HIGH for Global Clock	1.40		ns
$t_{RCKMPWL}$	Minimum Pulse Width LOW for Global Clock	1.65		ns
t_{RCKSW}	Maximum Skew for Global Clock		0.38	ns

Notes:

1. Value reflects minimum load. The delay is measured from the CCC output to the clock pin of a sequential element, located in a lightly loaded row (single element is connected to the global net).
2. Value reflects maximum load. The delay is measured on the clock pin of the farthest sequential element, located in a fully loaded row (all available flip-flops are connected to the global net in the row).
3. For specific junction temperature and voltage supply levels, refer to [Table 2-6 on page 2-6](#) for derating values.

Table 2-92 • AGLN125 Global Resource
Commercial-Case Conditions: $T_J = 70^\circ\text{C}$, $V_{CC} = 1.425\text{ V}$

Parameter	Description	Std.		Units
		Min. ¹	Max. ²	
t_{RCKL}	Input Low Delay for Global Clock	1.36	1.71	ns
t_{RCKH}	Input High Delay for Global Clock	1.39	1.82	ns
$t_{RCKMPWH}$	Minimum Pulse Width High for Global Clock	1.40		ns
$t_{RCKMPWL}$	Minimum Pulse Width Low for Global Clock	1.65		ns
t_{RCKSW}	Maximum Skew for Global Clock		0.43	ns

Notes:

1. Value reflects minimum load. The delay is measured from the CCC output to the clock pin of a sequential element, located in a lightly loaded row (single element is connected to the global net).
2. Value reflects maximum load. The delay is measured on the clock pin of the farthest sequential element, located in a fully loaded row (all available flip-flops are connected to the global net in the row).
3. For specific junction temperature and voltage supply levels, refer to [Table 2-6 on page 2-6](#) for derating values.

Table 2-93 • AGLN250 Global Resource
Commercial-Case Conditions: $T_J = 70^\circ\text{C}$, $V_{CC} = 1.425\text{ V}$

Parameter	Description	Std.		Units
		Min. ¹	Max. ²	
t_{RCKL}	Input Low Delay for Global Clock	1.39	1.73	ns
t_{RCKH}	Input High Delay for Global Clock	1.41	1.84	ns
$t_{RCKMPWH}$	Minimum Pulse Width High for Global Clock	1.40		ns
$t_{RCKMPWL}$	Minimum Pulse Width Low for Global Clock	1.65		ns
t_{RCKSW}	Maximum Skew for Global Clock		0.43	ns

Notes:

1. Value reflects minimum load. The delay is measured from the CCC output to the clock pin of a sequential element, located in a lightly loaded row (single element is connected to the global net).
2. Value reflects maximum load. The delay is measured on the clock pin of the farthest sequential element, located in a fully loaded row (all available flip-flops are connected to the global net in the row).
3. For specific junction temperature and voltage supply levels, refer to [Table 2-6 on page 2-6](#) for derating values.

1.2 V DC Core Voltage
Table 2-94 • AGLN010 Global Resource
Commercial-Case Conditions: $T_J = 70^\circ\text{C}$, $V_{CC} = 1.14\text{ V}$

Parameter	Description	Std.		Units
		Min. ¹	Max. ²	
t_{RCKL}	Input Low Delay for Global Clock	1.71	2.09	ns
t_{RCKH}	Input High Delay for Global Clock	1.78	2.31	ns
$t_{RCKMPWH}$	Minimum Pulse Width High for Global Clock	1.40		ns
$t_{RCKMPWL}$	Minimum Pulse Width Low for Global Clock	1.65		ns
t_{RCKSW}	Maximum Skew for Global Clock		0.53	ns

Notes:

1. Value reflects minimum load. The delay is measured from the CCC output to the clock pin of a sequential element, located in a lightly loaded row (single element is connected to the global net).
2. Value reflects maximum load. The delay is measured on the clock pin of the farthest sequential element, located in a fully loaded row (all available flip-flops are connected to the global net in the row).
3. For specific junction temperature and voltage supply levels, refer to [Table 2-7 on page 2-7](#) for derating values.

Table 2-95 • AGLN020 Global Resource
Commercial-Case Conditions: $T_J = 70^\circ\text{C}$, $V_{CC} = 1.14\text{ V}$

Parameter	Description	Std.		Units
		Min. ¹	Max. ²	
t_{RCKL}	Input Low Delay for Global Clock	1.81	2.26	ns
t_{RCKH}	Input High Delay for Global Clock	1.90	2.51	ns
$t_{RCKMPWH}$	Minimum Pulse Width High for Global Clock	1.40		ns
$t_{RCKMPWL}$	Minimum Pulse Width Low for Global Clock	1.65		ns
t_{RCKSW}	Maximum Skew for Global Clock		0.61	ns

Notes:

1. Value reflects minimum load. The delay is measured from the CCC output to the clock pin of a sequential element, located in a lightly loaded row (single element is connected to the global net).
2. Value reflects maximum load. The delay is measured on the clock pin of the farthest sequential element, located in a fully loaded row (all available flip-flops are connected to the global net in the row).
3. For specific junction temperature and voltage supply levels, refer to [Table 2-7 on page 2-7](#) for derating values.

Table 2-96 • AGLN060 Global Resource
Commercial-Case Conditions: $T_J = 70^\circ\text{C}$, $V_{CC} = 1.14\text{ V}$

Parameter	Description	Std.		Units
		Min. ¹	Max. ²	
t_{RCKL}	Input Low Delay for Global Clock	2.02	2.42	ns
t_{RCKH}	Input High Delay for Global Clock	2.09	2.65	ns
$t_{RCKMPWH}$	Minimum Pulse Width High for Global Clock	1.40		ns
$t_{RCKMPWL}$	Minimum Pulse Width Low for Global Clock	1.65		ns
t_{RCKSW}	Maximum Skew for Global Clock		0.56	ns

Notes:

1. Value reflects minimum load. The delay is measured from the CCC output to the clock pin of a sequential element, located in a lightly loaded row (single element is connected to the global net).
2. Value reflects maximum load. The delay is measured on the clock pin of the farthest sequential element, located in a fully loaded row (all available flip-flops are connected to the global net in the row).
3. For specific junction temperature and voltage supply levels, refer to [Table 2-7 on page 2-7](#) for derating values.

Table 2-97 • AGLN125 Global Resource
Commercial-Case Conditions: $T_J = 70^\circ\text{C}$, $V_{CC} = 1.14\text{ V}$

Parameter	Description	Std.		Units
		Min. ¹	Max. ²	
t_{RCKL}	Input Low Delay for Global Clock	2.08	2.54	ns
t_{RCKH}	Input High Delay for Global Clock	2.15	2.77	ns
$t_{RCKMPWH}$	Minimum Pulse Width HIGH for Global Clock	1.40		ns
$t_{RCKMPWL}$	Minimum Pulse Width LOW for Global Clock	1.65		ns
t_{RCKSW}	Maximum Skew for Global Clock		0.62	ns

Notes:

1. Value reflects minimum load. The delay is measured from the CCC output to the clock pin of a sequential element, located in a lightly loaded row (single element is connected to the global net).
2. Value reflects maximum load. The delay is measured on the clock pin of the farthest sequential element, located in a fully loaded row (all available flip-flops are connected to the global net in the row).
3. For specific junction temperature and voltage supply levels, refer to [Table 2-7 on page 2-7](#) for derating values.

Table 2-98 • AGLN250 Global Resource
Commercial-Case Conditions: $T_J = 70^\circ\text{C}$, $V_{CC} = 1.14\text{ V}$

Parameter	Description	Std.		Units
		Min. ¹	Max. ²	
t_{RCKL}	Input Low Delay for Global Clock	2.11	2.57	ns
t_{RCKH}	Input High Delay for Global Clock	2.19	2.81	ns
$t_{RCKMPWH}$	Minimum Pulse Width High for Global Clock	1.40		ns
$t_{RCKMPWL}$	Minimum Pulse Width Low for Global Clock	1.65		ns
t_{RCKSW}	Maximum Skew for Global Clock		0.62	ns

Notes:

1. Value reflects minimum load. The delay is measured from the CCC output to the clock pin of a sequential element, located in a lightly loaded row (single element is connected to the global net).
2. Value reflects maximum load. The delay is measured on the clock pin of the farthest sequential element, located in a fully loaded row (all available flip-flops are connected to the global net in the row).
3. For specific junction temperature and voltage supply levels, refer to [Table 2-7 on page 2-7](#) for derating values.

Clock Conditioning Circuits

CCC Electrical Specifications

Timing Characteristics

Table 2-99 • IGLOO nano CCC/PLL Specification
For IGLOO nano V2 OR V5 Devices, 1.5 V DC Core Supply Voltage

Parameter	Min.	Typ.	Max.	Units
Clock Conditioning Circuitry Input Frequency f_{IN_CCC}	1.5		250	MHz
Clock Conditioning Circuitry Output Frequency f_{OUT_CCC}	0.75		250	MHz
Delay Increments in Programmable Delay Blocks ^{1,2}		360 ³		ps
Number of Programmable Values in Each Programmable Delay Block			32	
Serial Clock (SCLK) for Dynamic PLL ^{4,9}			100	MHz
Input Cycle-to-Cycle Jitter (peak magnitude)			1	ns
Acquisition Time				
			6.0	ms
Tracking Jitter ⁵				
			1.5	ns
Output Duty Cycle	48.5		51.5	%
Delay Range in Block: Programmable Delay 1 ^{1,2}	1.25		15.65	ns
Delay Range in Block: Programmable Delay 2 ^{1,2}	0.025		15.65	ns
Delay Range in Block: Fixed Delay ^{1,2}		3.5		ns
VCO Output Peak-to-Peak Period Jitter F_{CCC_OUT} ⁶	Max Peak-to-Peak Jitter Data ^{6,7,8}			
	SSO ≤ 2	SSO ≤ 4	SSO ≤ 8	SSO ≤ 16
0.75 MHz to 50 MHz	0.50	0.60	0.80	1.20
50 MHz to 250 MHz	2.50	4.00	6.00	12.00

Notes:

1. This delay is a function of voltage and temperature. See [Table 2-6 on page 2-6](#) and [Table 2-7 on page 2-7](#) for deratings.
2. $T_J = 25^\circ\text{C}$, $V_{CC} = 1.5\text{ V}$
3. When the CCC/PLL core is generated by Microsemi core generator software, not all delay values of the specified delay increments are available. Refer to the [Libero SoC Online Help](#) associated with the core for more information.
4. Maximum value obtained for a STD speed grade device in Worst-Case Commercial conditions. For specific junction temperature and voltage supply levels, refer to [Table 2-6 on page 2-6](#) and [Table 2-7 on page 2-7](#) for derating values.
5. Tracking jitter is defined as the variation in clock edge position of PLL outputs with reference to PLL input clock edge. Tracking jitter does not measure the variation in PLL output period, which is covered by the period jitter parameter.
6. VCO output jitter is calculated as a percentage of the VCO frequency. The jitter (in ps) can be calculated by multiplying the VCO period by the % jitter. The VCO jitter (in ps) applies to CCC_OUT, regardless of the output divider settings. For example, if the jitter on VCO is 300 ps, the jitter on CCC_OUT is also 300 ps, no matter what the settings are for the output divider.
7. Measurements done with LVTTTL 3.3 V 8 mA I/O drive strength and high slew rate. $V_{CC}/V_{CCPLL} = 1.425\text{ V}$, $V_{CCI} = 3.3\text{ V}$, VQ/PQ/TQ type of packages, 20 pF load.
8. SSOs are outputs that are synchronous to a single clock domain and have their clock-to-out times within ±200 ps of each other. Switching I/Os are placed outside of the PLL bank. Refer to the "Simultaneously Switching Outputs (SSOs) and Printed Circuit Board Layout" section in the [IGLOO nano FPGA Fabric User's Guide](#).
9. The AGLN010 and AGLN020 devices do not support PLLs.

**Table 2-100 • IGLOO nano CCC/PLL Specification
For IGLOO nano V2 Devices, 1.2 V DC Core Supply Voltage**

Parameter	Min.	Typ.	Max.	Units	
Clock Conditioning Circuitry Input Frequency f_{IN_CCC}	1.5		160	MHz	
Clock Conditioning Circuitry Output Frequency f_{OUT_CCC}	0.75		160	MHz	
Delay Increments in Programmable Delay Blocks ^{1, 2}		580 ³		ps	
Number of Programmable Values in Each Programmable Delay Block			32		
Serial Clock (SCLK) for Dynamic PLL ^{4,9}			60		
Input Cycle-to-Cycle Jitter (peak magnitude)			0.25	ns	
Acquisition Time					
					LockControl = 0
			6.0	ms	
Tracking Jitter ⁵					
					LockControl = 0
			3	ns	
Output Duty Cycle	48.5		51.5	%	
Delay Range in Block: Programmable Delay 1 ^{1, 2}	2.3		20.86	ns	
Delay Range in Block: Programmable Delay 2 ^{1, 2}	0.025		20.86	ns	
Delay Range in Block: Fixed Delay ^{1, 2}		5.7		ns	
VCO Output Peak-to-Peak Period Jitter F_{CCC_OUT} ⁶	Max Peak-to-Peak Period Jitter ^{6,7,8}				
	SSO ≤ 2	SSO ≤ 4	SSO ≤ 8	SSO ≤ 16	
0.75 MHz to 50MHz	0.50	1.20	2.00	3.00	%
50 MHz to 100 MHz	2.50	5.00	7.00	15.00	%

Notes:

1. This delay is a function of voltage and temperature. See [Table 2-6 on page 2-6](#) and [Table 2-7 on page 2-7](#) for deratings.
2. $T_J = 25^\circ\text{C}$, $V_{CC} = 1.2\text{ V}$.
3. When the CCC/PLL core is generated by Microsemi core generator software, not all delay values of the specified delay increments are available. Refer to the [Liberio SoC Online Help](#) associated with the core for more information.
4. Maximum value obtained for a STD speed grade device in Worst-Case Commercial conditions. For specific junction temperature and voltage supply levels, refer to [Table 2-6 on page 2-6](#) and [Table 2-7 on page 2-7](#) for derating values.
5. Tracking jitter is defined as the variation in clock edge position of PLL outputs with reference to the PLL input clock edge. Tracking jitter does not measure the variation in PLL output period, which is covered by the period jitter parameter.
6. VCO output jitter is calculated as a percentage of the VCO frequency. The jitter (in ps) can be calculated by multiplying the VCO period by the % jitter. The VCO jitter (in ps) applies to CCC_OUT, regardless of the output divider settings. For example, if the jitter on VCO is 300 ps, the jitter on CCC_OUT is also 300 ps, no matter what the settings are for the output divider.
7. Measurements done with LVTTTL 3.3 V 8 mA I/O drive strength and high slew rate. $V_{CC}/V_{CCPLL} = 1.14\text{ V}$, $V_{CCI} = 3.3\text{ V}$, VQ/PQ/TQ type of packages, 20 pF load.
8. SSOs are outputs that are synchronous to a single clock domain and have their clock-to-out times within $\pm 200\text{ ps}$ of each other. Switching I/Os are placed outside of the PLL bank. Refer to the "Simultaneously Switching Outputs (SSOs) and Printed Circuit Board Layout" section in the [IGLOO nano FPGA Fabric User's Guide](#).
9. The AGLN010, AGLN015, and AGLN020 devices do not support PLLs.

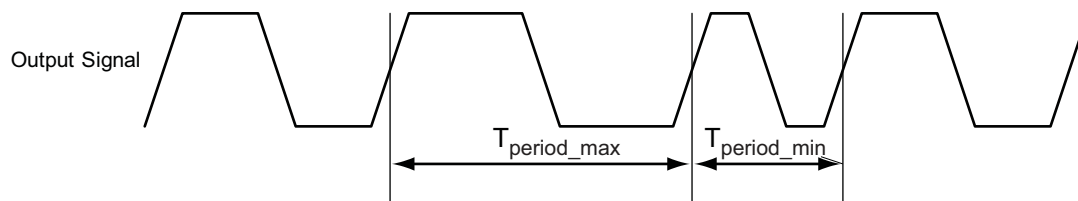

Note: Peak-to-peak jitter measurements are defined by $T_{\text{peak-to-peak}} = T_{\text{period_max}} - T_{\text{period_min}}$.

Figure 2-26 • Peak-to-Peak Jitter Definition

Embedded SRAM and FIFO Characteristics

SRAM

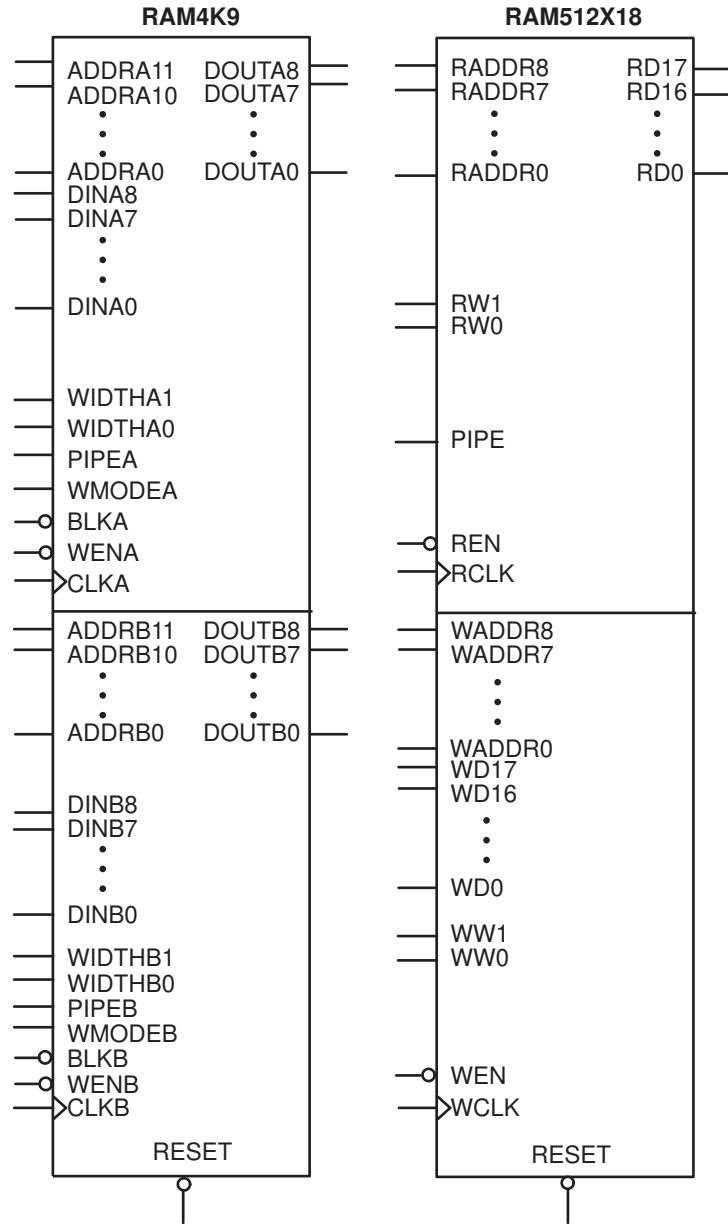

Figure 2-27 • RAM Models

Timing Waveforms

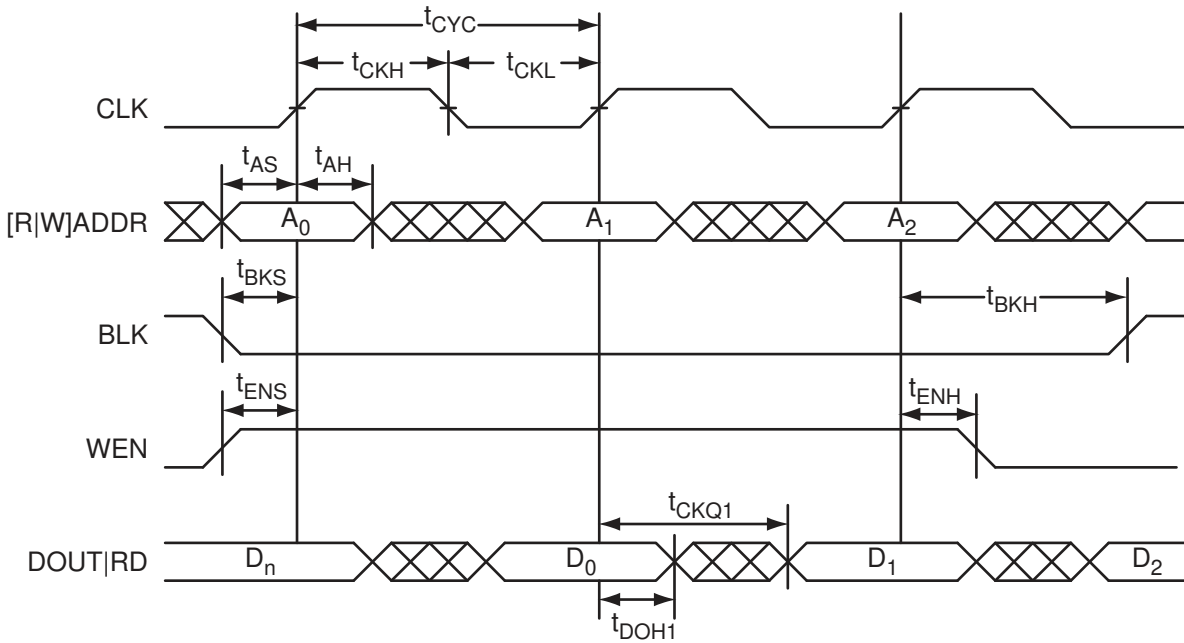

Figure 2-28 • RAM Read for Pass-Through Output. Applicable to Both RAM4K9 and RAM512x18.

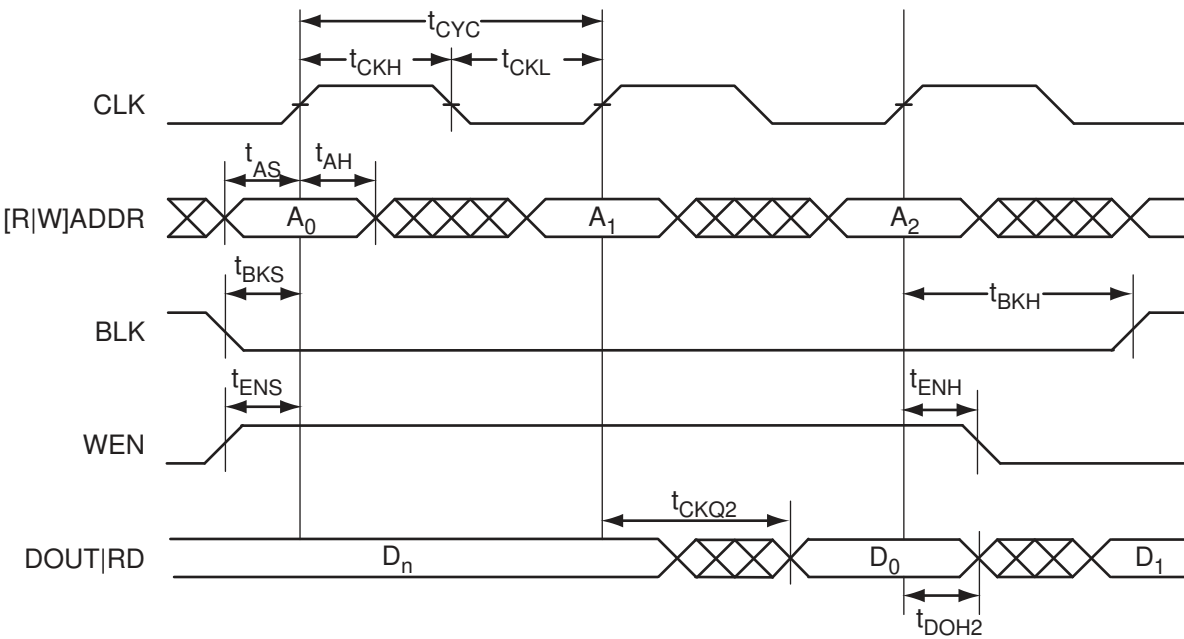

Figure 2-29 • RAM Read for Pipelined Output. Applicable to Both RAM4K9 and RAM512x18.

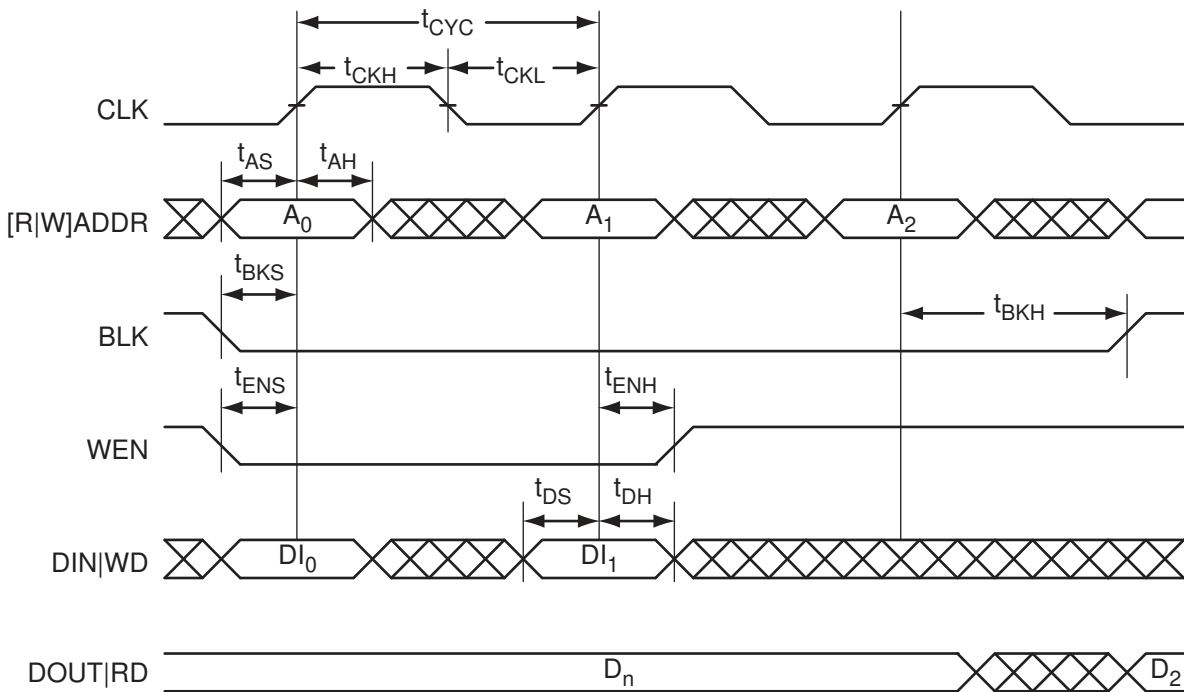

Figure 2-30 • RAM Write, Output Retained (WMODE = 0). Applicable to Both RAM4K9 and RAM512x18.

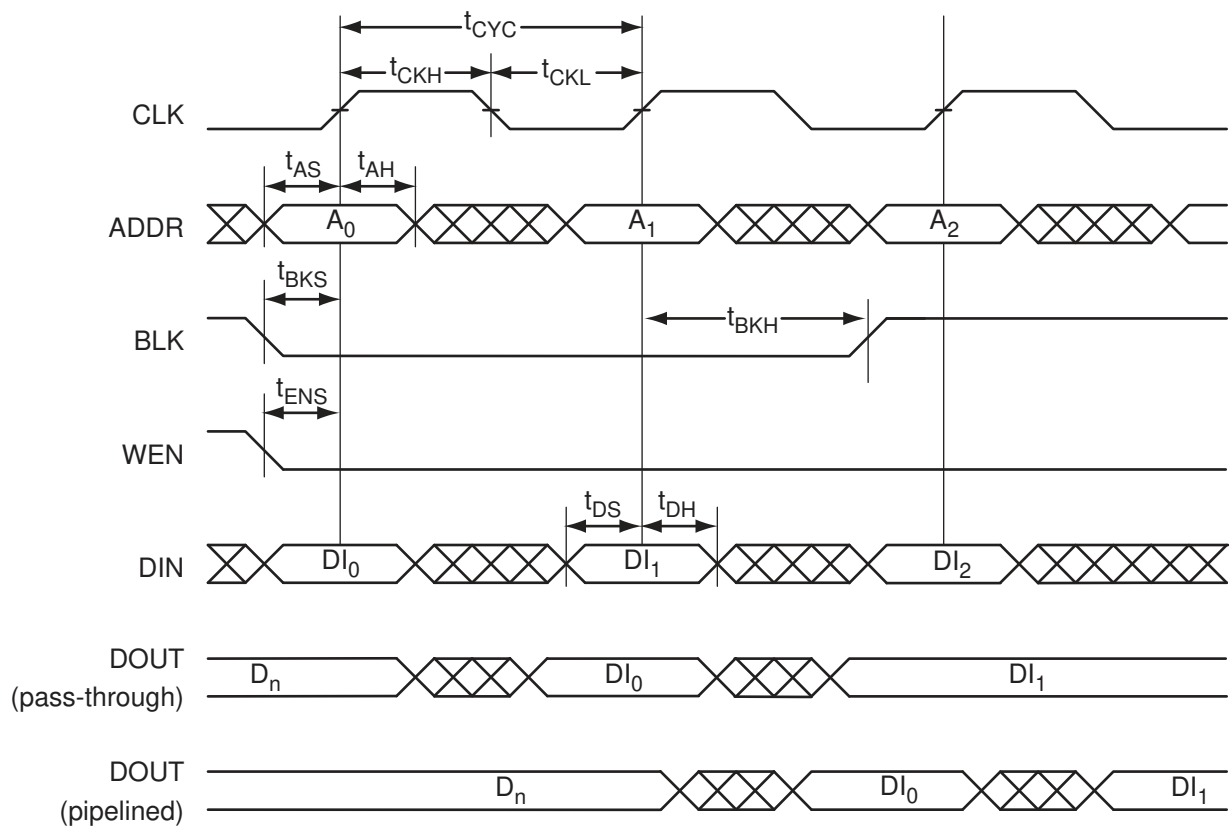

Figure 2-31 • RAM Write, Output as Write Data (WMODE = 1). Applicable to RAM4K9 Only.

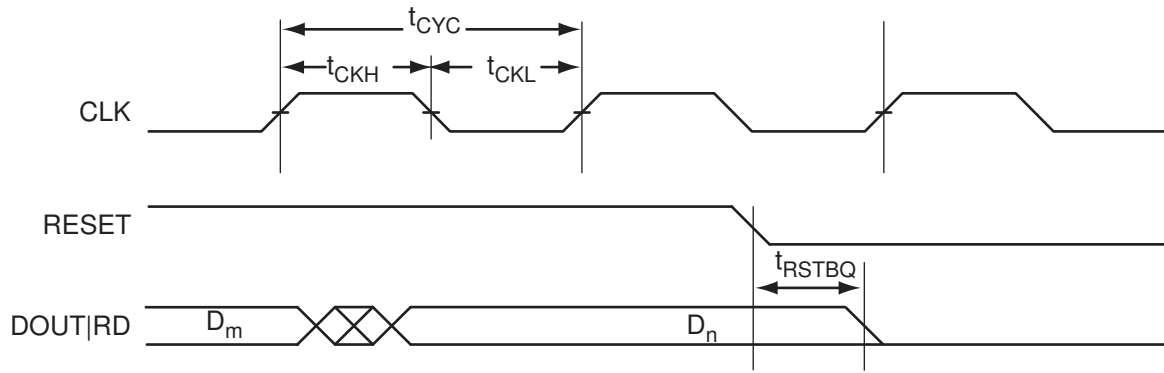

Figure 2-32 • RAM Reset. Applicable to Both RAM4K9 and RAM512x18.

Timing Characteristics

1.5 V DC Core Voltage

Table 2-101 • RAM4K9

Commercial-Case Conditions: $T_J = 70^\circ\text{C}$, Worst-Case $V_{CC} = 1.425\text{ V}$

Parameter	Description	Std.	Units
t_{AS}	Address setup time	0.69	ns
t_{AH}	Address hold time	0.13	ns
t_{ENS}	REN, WEN setup time	0.68	ns
t_{ENH}	REN, WEN hold time	0.13	ns
t_{BKS}	BLK setup time	1.37	ns
t_{BKH}	BLK hold time	0.13	ns
t_{DS}	Input data (DIN) setup time	0.59	ns
t_{DH}	Input data (DIN) hold time	0.30	ns
t_{CKQ1}	Clock HIGH to new data valid on DOUT (output retained, WMODE = 0)	2.94	ns
	Clock HIGH to new data valid on DOUT (flow-through, WMODE = 1)	2.55	ns
t_{CKQ2}	Clock HIGH to new data valid on DOUT (pipelined)	1.51	ns
t_{C2CWWL}^1	Address collision clk-to-clk delay for reliable write after write on same address; applicable to closing edge	0.23	ns
t_{C2CRWH}^1	Address collision clk-to-clk delay for reliable read access after write on same address; applicable to opening edge	0.35	ns
t_{C2CWRH}^1	Address collision clk-to-clk delay for reliable write access after read on same address; applicable to opening edge	0.41	ns
t_{RSTBQ}	RESET Low to data out Low on DOUT (flow-through)	1.72	ns
	RESET Low to data out Low on DOUT (pipelined)	1.72	ns
$t_{REMRSTB}$	RESET removal	0.51	ns
$t_{RECRSTB}$	RESET recovery	2.68	ns
$t_{MPWRSTB}$	RESET minimum pulse width	0.68	ns
t_{CYC}	Clock cycle time	6.24	ns
F_{MAX}	Maximum frequency	160	MHz

Notes:

1. For more information, refer to the application note [AC374: Simultaneous Read-Write Operations in Dual-Port SRAM for Flash-Based FPGAs and SoC FPGAs App Note](#).
2. For specific junction temperature and voltage supply levels, refer to [Table 2-6 on page 2-6](#) for derating values.

Table 2-102 • RAM512X18

Commercial-Case Conditions: $T_J = 70^\circ\text{C}$, Worst-Case $V_{CC} = 1.425\text{ V}$

Parameter	Description	Std.	Units
t_{AS}	Address setup time	0.69	ns
t_{AH}	Address hold time	0.13	ns
t_{ENS}	REN, WEN setup time	0.61	ns
t_{ENH}	REN, WEN hold time	0.07	ns
t_{DS}	Input data (WD) setup time	0.59	ns
t_{DH}	Input data (WD) hold time	0.30	ns
t_{CKQ1}	Clock HIGH to new data valid on RD (output retained)	3.51	ns
t_{CKQ2}	Clock HIGH to new data valid on RD (pipelined)	1.43	ns
t_{C2CRWH}^1	Address collision clk-to-clk delay for reliable read access after write on same address; applicable to opening edge	0.35	ns
t_{C2CWRH}^1	Address collision clk-to-clk delay for reliable write access after read on same address; applicable to opening edge	0.42	ns
t_{RSTBQ}	RESET Low to data out Low on RD (flow-through)	1.72	ns
	RESET Low to data out Low on RD (pipelined)	1.72	ns
$t_{REMRSTB}$	RESET removal	0.51	0.51
$t_{RECRSTB}$	RESET recovery	2.68	ns
$t_{MPWRSTB}$	RESET minimum pulse width	0.68	ns
t_{CYC}	Clock cycle time	6.24	ns
F_{MAX}	Maximum frequency	160	MHz

Notes:

1. For more information, refer to the application note [AC374: Simultaneous Read-Write Operations in Dual-Port SRAM for Flash-Based FPGAs and SoC FPGAs App Note](#).
2. For specific junction temperature and voltage supply levels, refer to [Table 2-6 on page 2-6](#) for derating values.

1.2 V DC Core Voltage

Table 2-103 • RAM4K9

Commercial-Case Conditions: $T_J = 70^\circ\text{C}$, Worst-Case $V_{CC} = 1.14\text{ V}$

Parameter	Description	Std.	Units
t_{AS}	Address setup time	1.28	ns
t_{AH}	Address hold time	0.25	ns
t_{ENS}	REN, WEN setup time	1.25	ns
t_{ENH}	REN, WEN hold time	0.25	ns
t_{BKS}	BLK setup time	2.54	ns
t_{BKH}	BLK hold time	0.25	ns
t_{DS}	Input data (DIN) setup time	1.10	ns
t_{DH}	Input data (DIN) hold time	0.55	ns
t_{CKQ1}	Clock HIGH to new data valid on DOUT (output retained, WMODE = 0)	5.51	ns
	Clock HIGH to new data valid on DOUT (flow-through, WMODE = 1)	4.77	ns
t_{CKQ2}	Clock HIGH to new data valid on DOUT (pipelined)	2.82	ns
t_{C2CWWL}^1	Address collision clk-to-clk delay for reliable write after write on same address; applicable to closing edge	0.30	ns
t_{C2CRWH}^1	Address collision clk-to-clk delay for reliable read access after write on same address; applicable to opening edge	0.89	ns
t_{C2CWRH}^1	Address collision clk-to-clk delay for reliable write access after read on same address; applicable to opening edge	1.01	ns
t_{RSTBQ}	RESET LOW to data out LOW on DOUT (flow-through)	3.21	ns
	RESET LOW to data out LOW on DO (pipelined)	3.21	ns
$t_{REMRSTB}$	RESET removal	0.93	ns
$t_{RECRSTB}$	RESET recovery	4.94	ns
$t_{MPWRSTB}$	RESET minimum pulse width	1.18	ns
t_{CYC}	Clock cycle time	10.90	ns
F_{MAX}	Maximum frequency	92	MHz

Notes:

1. For more information, refer to the application note [AC374: Simultaneous Read-Write Operations in Dual-Port SRAM for Flash-Based FPGAs and SoC FPGAs App Note](#).
2. For specific junction temperature and voltage supply levels, refer to [Table 2-7 on page 2-7](#) for derating values.

Table 2-104 • RAM512X18

Commercial-Case Conditions: $T_J = 70^\circ\text{C}$, Worst-Case $V_{CC} = 1.14\text{ V}$

Parameter	Description	Std.	Units
t_{AS}	Address setup time	1.28	ns
t_{AH}	Address hold time	0.25	ns
t_{ENS}	REN, WEN setup time	1.13	ns
t_{ENH}	REN, WEN hold time	0.13	ns
t_{DS}	Input data (WD) setup time	1.10	ns
t_{DH}	Input data (WD) hold time	0.55	ns
t_{CKQ1}	Clock High to new data valid on RD (output retained)	6.56	ns
t_{CKQ2}	Clock High to new data valid on RD (pipelined)	2.67	ns
t_{C2CRWH}^1	Address collision clk-to-clk delay for reliable read access after write on same address; applicable to opening edge	0.87	ns
t_{C2CWRH}^1	Address collision clk-to-clk delay for reliable write access after read on same address; applicable to opening edge	1.04	ns
t_{RSTBQ}	RESET LOW to data out LOW on RD (flow through)	3.21	ns
	RESET LOW to data out LOW on RD (pipelined)	3.21	ns
$t_{REMRSTB}$	RESET removal	0.93	ns
$t_{RECRSTB}$	RESET recovery	4.94	ns
$t_{MPWRSTB}$	RESET minimum pulse width	1.18	ns
t_{CYC}	Clock cycle time	10.90	ns
F_{MAX}	Maximum frequency	92	MHz

Notes:

1. For more information, refer to the application note [AC374: Simultaneous Read-Write Operations in Dual-Port SRAM for Flash-Based FPGAs and SoC FPGAs App Note](#).
2. For specific junction temperature and voltage supply levels, refer to [Table 2-7 on page 2-7](#) for derating values.

FIFO

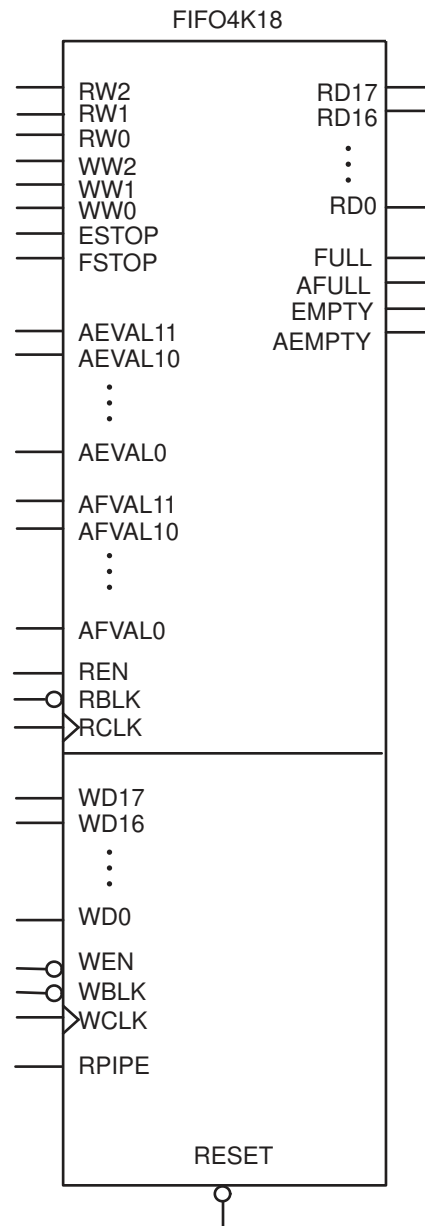

Figure 2-33 • FIFO Model

Timing Waveforms

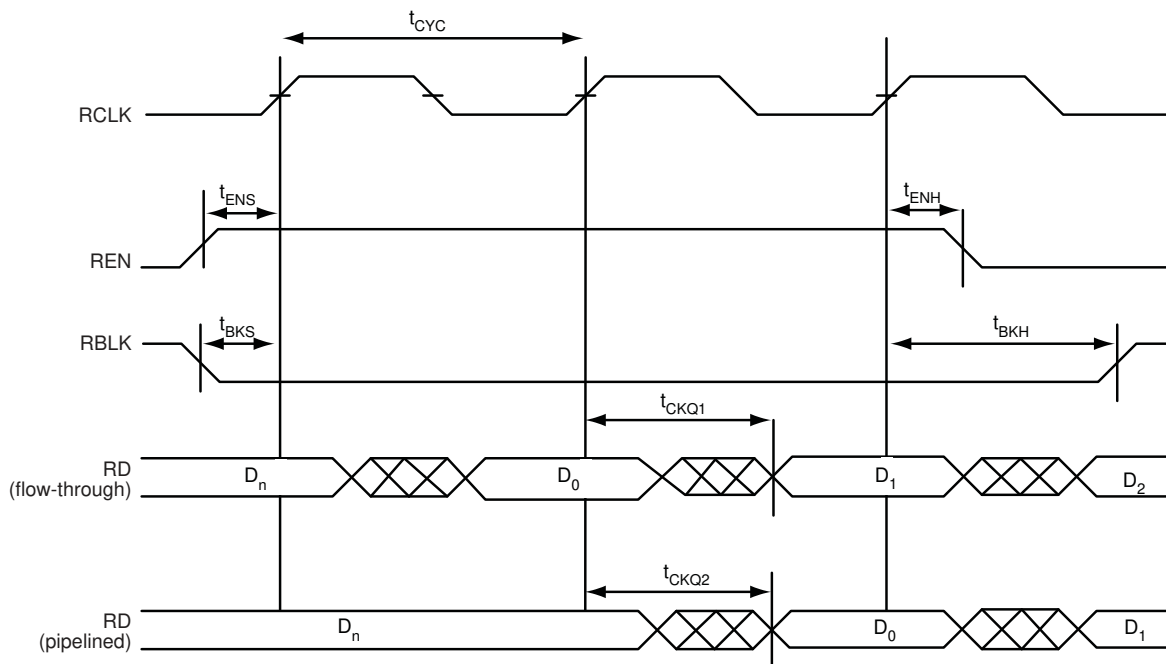

Figure 2-34 • FIFO Read

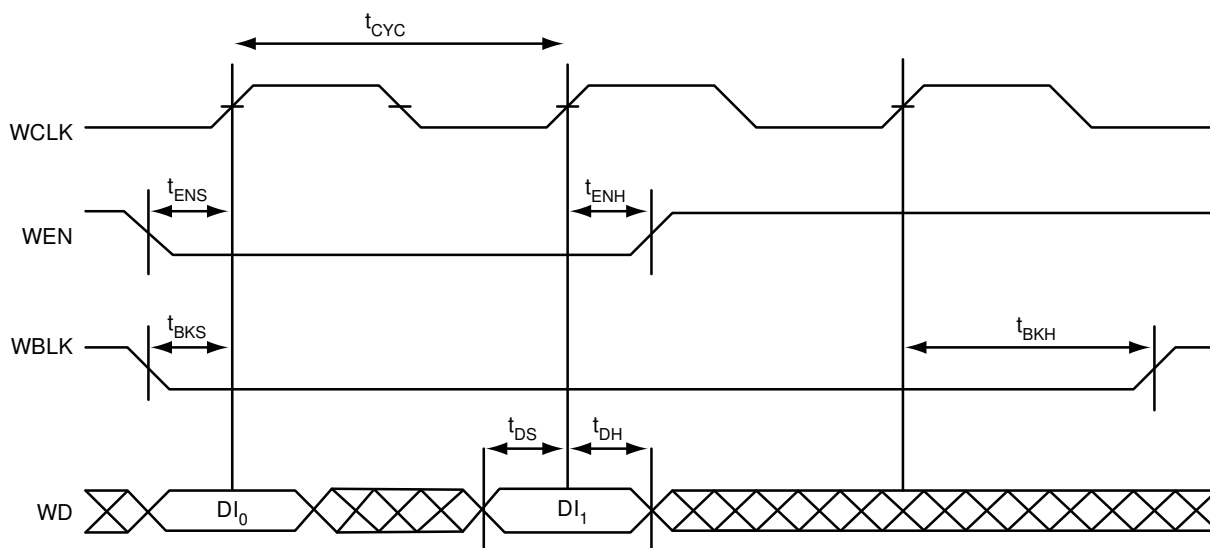

Figure 2-35 • FIFO Write

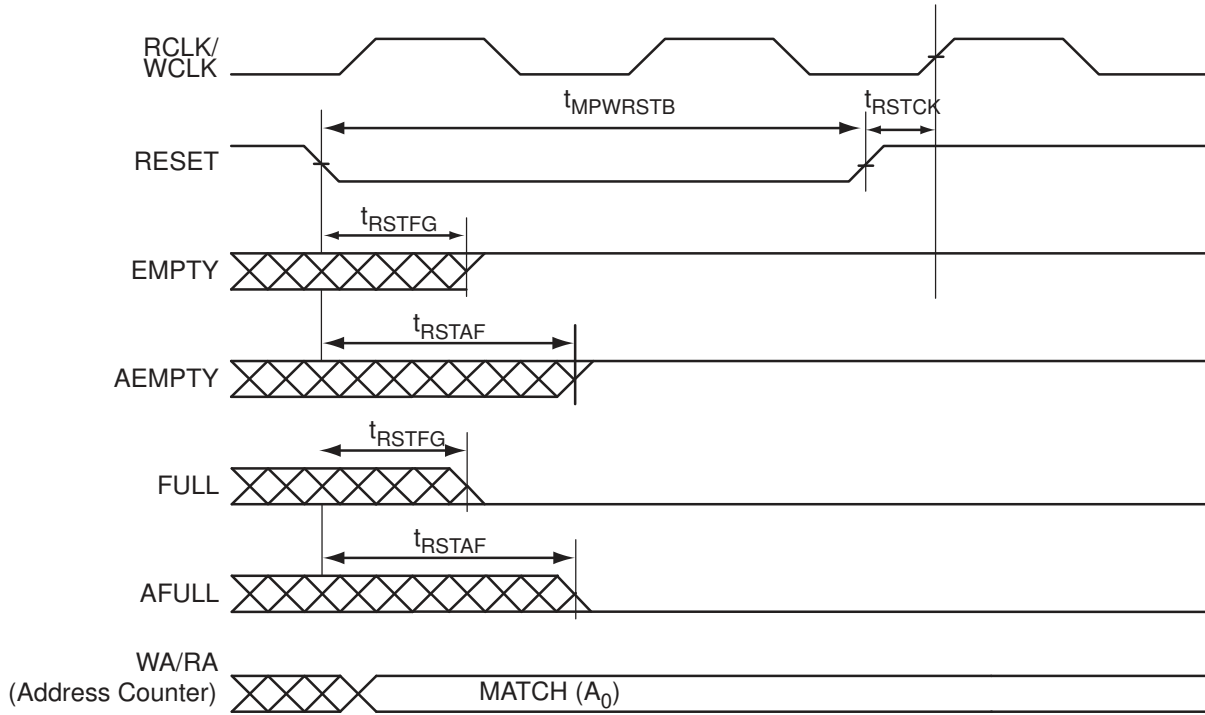

Figure 2-36 • FIFO Reset

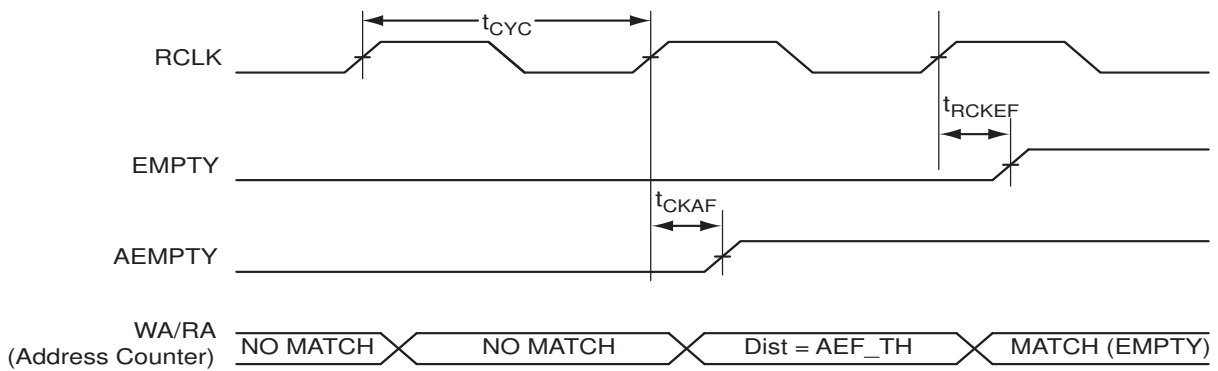

Figure 2-37 • FIFO EMPTY Flag and AEMPTY Flag Assertion

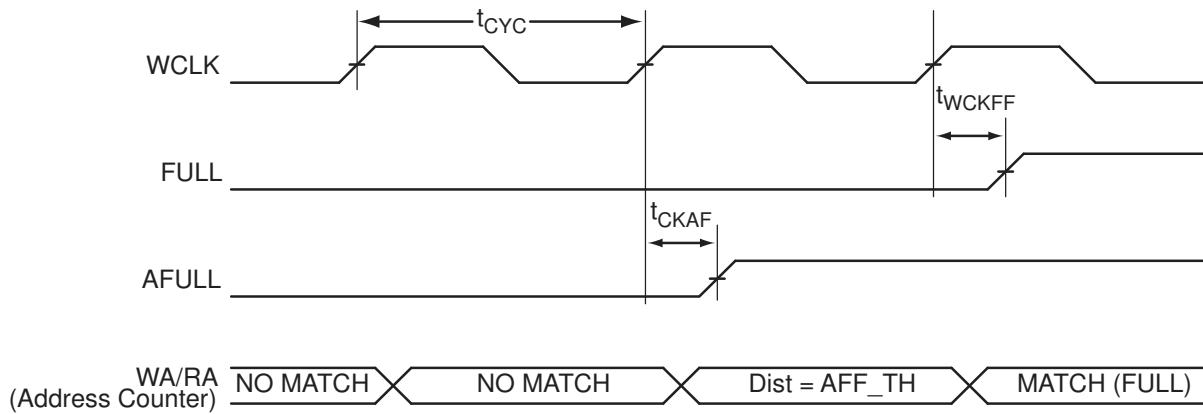

Figure 2-38 • FIFO FULL Flag and AFULL Flag Assertion

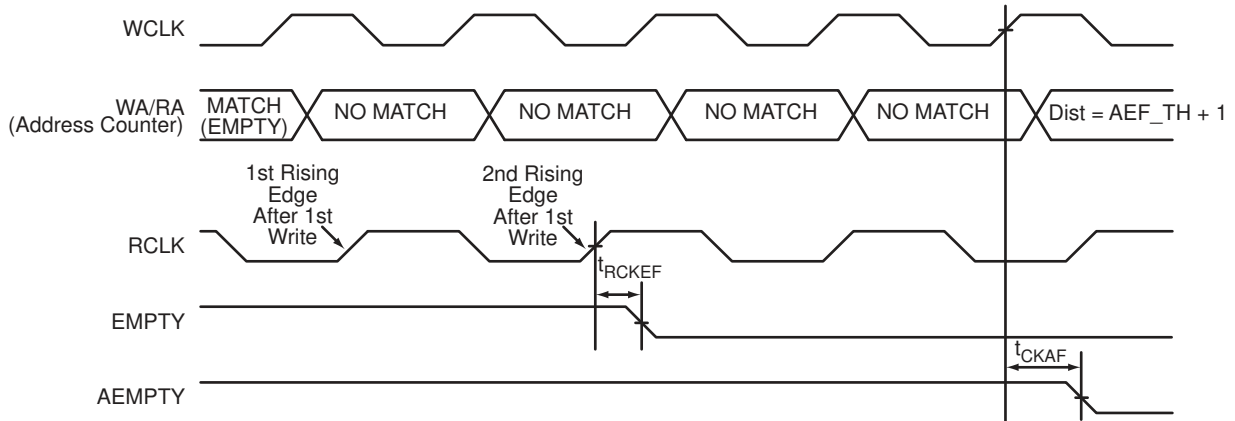

Figure 2-39 • FIFO EMPTY Flag and AEMPTY Flag Deassertion

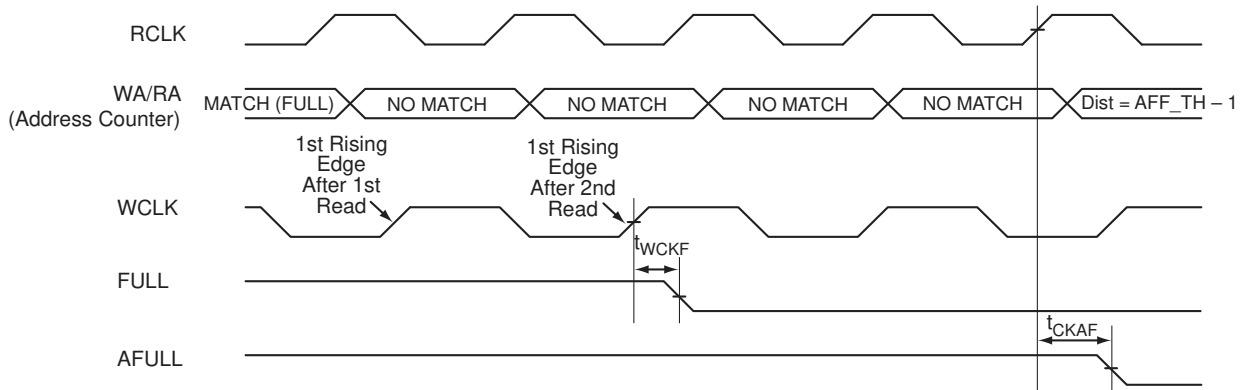

Figure 2-40 • FIFO FULL Flag and AFULL Flag Deassertion

Timing Characteristics

1.5 V DC Core Voltage

Table 2-105 • FIFO

Worst Commercial-Case Conditions: $T_J = 70^\circ\text{C}$, $V_{CC} = 1.425\text{ V}$

Parameter	Description	Std.	Units
t_{ENS}	REN, WEN Setup Time	1.66	ns
t_{ENH}	REN, WEN Hold Time	0.13	ns
t_{BKS}	BLK Setup Time	0.30	ns
t_{BKH}	BLK Hold Time	0.00	ns
t_{DS}	Input Data (WD) Setup Time	0.63	ns
t_{DH}	Input Data (WD) Hold Time	0.20	ns
t_{CKQ1}	Clock High to New Data Valid on RD (flow-through)	2.77	ns
t_{CKQ2}	Clock High to New Data Valid on RD (pipelined)	1.50	ns
t_{RCKEF}	RCLK High to Empty Flag Valid	2.94	ns
t_{WCKFF}	WCLK High to Full Flag Valid	2.79	ns
t_{CKAF}	Clock High to Almost Empty/Full Flag Valid	10.71	ns
t_{RSTFG}	RESET Low to Empty/Full Flag Valid	2.90	ns
t_{RSTAF}	RESET Low to Almost Empty/Full Flag Valid	10.60	ns
t_{RSTBQ}	RESET Low to Data Out LOW on RD (flow-through)	1.68	ns
	RESET Low to Data Out LOW on RD (pipelined)	1.68	ns
$t_{REMRSTB}$	RESET Removal	0.51	ns
$t_{RECRSTB}$	RESET Recovery	2.68	ns
$t_{MPWRSTB}$	RESET Minimum Pulse Width	0.68	ns
t_{CYC}	Clock Cycle Time	6.24	ns
F_{MAX}	Maximum Frequency for FIFO	160	MHz

Note: For specific junction temperature and voltage supply levels, refer to [Table 2-6 on page 2-6](#) for derating values.

1.2 V DC Core Voltage

Table 2-106 • FIFO

Worst Commercial-Case Conditions: $T_J = 70^\circ\text{C}$, $V_{CC} = 1.14\text{ V}$

Parameter	Description	Std.	Units
t_{ENS}	REN, WEN Setup Time	3.44	ns
t_{ENH}	REN, WEN Hold Time	0.26	ns
t_{BKS}	BLK Setup Time	0.30	ns
t_{BKH}	BLK Hold Time	0.00	ns
t_{DS}	Input Data (DI) Setup Time	1.30	ns
t_{DH}	Input Data (DI) Hold Time	0.41	ns
t_{CKQ1}	Clock High to New Data Valid on RD (flow-through)	5.67	ns
t_{CKQ2}	Clock High to New Data Valid on RD (pipelined)	3.02	ns
t_{RCKEF}	RCLK High to Empty Flag Valid	6.02	ns
t_{WCKFF}	WCLK High to Full Flag Valid	5.71	ns
t_{CKAF}	Clock High to Almost Empty/Full Flag Valid	22.17	ns
t_{RSTFG}	RESET LOW to Empty/Full Flag Valid	5.93	ns
t_{RSTAF}	RESET LOW to Almost Empty/Full Flag Valid	21.94	ns
t_{RSTBQ}	RESET LOW to Data Out Low on RD (flow-through)	3.41	ns
	RESET LOW to Data Out Low on RD (pipelined)	4.09	3.41
$t_{REMRSTB}$	RESET Removal	1.02	ns
$t_{RECRSTB}$	RESET Recovery	5.48	ns
$t_{MPWRSTB}$	RESET Minimum Pulse Width	1.18	ns
t_{CYC}	Clock Cycle Time	10.90	ns
F_{MAX}	Maximum Frequency for FIFO	92	MHz

Note: For specific junction temperature and voltage supply levels, refer to [Table 2-7 on page 2-7](#) for derating values.

Embedded FlashROM Characteristics

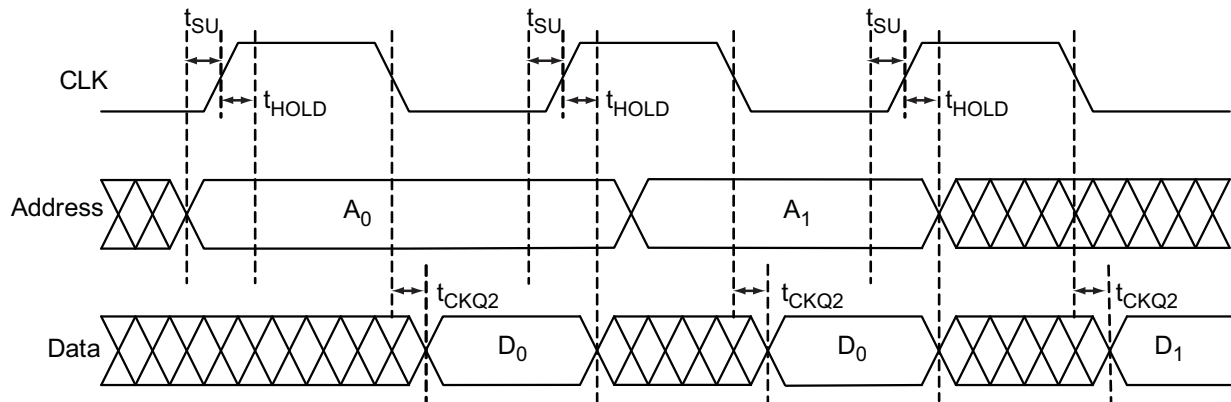

Figure 2-41 • Timing Diagram

Timing Characteristics

1.5 V DC Core Voltage

Table 2-107 • Embedded FlashROM Access Time

Worst Commercial-Case Conditions: $T_J = 70^\circ\text{C}$, $V_{CC} = 1.425\text{ V}$

Parameter	Description	Std.	Units
t_{SU}	Address Setup Time	0.57	ns
t_{HOLD}	Address Hold Time	0.00	ns
t_{CK2Q}	Clock to Out	20.90	ns
F_{MAX}	Maximum Clock Frequency	15	MHz

1.2 V DC Core Voltage

Table 2-108 • Embedded FlashROM Access Time

Worst Commercial-Case Conditions: $T_J = 70^\circ\text{C}$, $V_{CC} = 1.14\text{ V}$

Parameter	Description	Std.	Units
t_{SU}	Address Setup Time	0.59	ns
t_{HOLD}	Address Hold Time	0.00	ns
t_{CK2Q}	Clock to Out	35.74	ns
F_{MAX}	Maximum Clock Frequency	10	MHz

JTAG 1532 Characteristics

JTAG timing delays do not include JTAG I/Os. To obtain complete JTAG timing, add I/O buffer delays to the corresponding standard selected; refer to the I/O timing characteristics in the "User I/O Characteristics" section on page 2-15 for more details.

Timing Characteristics

1.5 V DC Core Voltage

Table 2-109 • JTAG 1532

Commercial-Case Conditions: $T_J = 70^\circ\text{C}$, Worst-Case $V_{CC} = 1.425\text{ V}$

Parameter	Description	Std.	Units
t_{DISU}	Test Data Input Setup Time	1.00	ns
t_{DIHD}	Test Data Input Hold Time	2.00	ns
t_{TMSSU}	Test Mode Select Setup Time	1.00	ns
t_{TMDHD}	Test Mode Select Hold Time	2.00	ns
t_{TCK2Q}	Clock to Q (data out)	8.00	ns
t_{RSTB2Q}	Reset to Q (data out)	25.00	ns
F_{TCKMAX}	TCK Maximum Frequency	15	MHz
$t_{TRSTREM}$	ResetB Removal Time	0.58	ns
$t_{TRSTREC}$	ResetB Recovery Time	0.00	ns
$t_{TRSTMPW}$	ResetB Minimum Pulse	TBD	ns

Note: For specific junction temperature and voltage supply levels, refer to Table 2-6 on page 2-6 for derating values.

1.2 V DC Core Voltage

Table 2-110 • JTAG 1532

Commercial-Case Conditions: $T_J = 70^\circ\text{C}$, Worst-Case $V_{CC} = 1.14\text{ V}$

Parameter	Description	Std.	Units
t_{DISU}	Test Data Input Setup Time	1.50	ns
t_{DIHD}	Test Data Input Hold Time	3.00	ns
t_{TMSSU}	Test Mode Select Setup Time	1.50	ns
t_{TMDHD}	Test Mode Select Hold Time	3.00	ns
t_{TCK2Q}	Clock to Q (data out)	11.00	ns
t_{RSTB2Q}	Reset to Q (data out)	30.00	ns
F_{TCKMAX}	TCK Maximum Frequency	9.00	MHz
$t_{TRSTREM}$	ResetB Removal Time	1.18	ns
$t_{TRSTREC}$	ResetB Recovery Time	0.00	ns
$t_{TRSTMPW}$	ResetB Minimum Pulse	TBD	ns

Note: For specific junction temperature and voltage supply levels, refer to Table 2-6 on page 2-6 for derating values.

3 – Pin Descriptions

Supply Pins

GND**Ground**

Ground supply voltage to the core, I/O outputs, and I/O logic.

GNDQ**Ground (quiet)**

Quiet ground supply voltage to input buffers of I/O banks. Within the package, the GNDQ plane is decoupled from the simultaneous switching noise originated from the output buffer ground domain. This minimizes the noise transfer within the package and improves input signal integrity. GNDQ must always be connected to GND on the board.

VCC**Core Supply Voltage**

Supply voltage to the FPGA core, nominally 1.5 V for IGLOO nano V5 devices, and 1.2 V or 1.5 V for IGLOO nano V2 devices. VCC is required for powering the JTAG state machine in addition to VJTAG. Even when a device is in bypass mode in a JTAG chain of interconnected devices, both VCC and VJTAG must remain powered to allow JTAG signals to pass through the device.

VCCIBx**I/O Supply Voltage**

Supply voltage to the bank's I/O output buffers and I/O logic. Bx is the I/O bank number. There are up to eight I/O banks on low power flash devices plus a dedicated VJTAG bank. Each bank can have a separate VCCI connection. All I/Os in a bank will run off the same VCCIBx supply. VCCI can be 1.2 V, 1.5 V, 1.8 V, 2.5 V, or 3.3 V, nominal voltage. Unused I/O banks should have their corresponding VCCI pins tied to GND.

VMVx**I/O Supply Voltage (quiet)**

Quiet supply voltage to the input buffers of each I/O bank. x is the bank number. Within the package, the VMV plane biases the input stage of the I/Os in the I/O banks. This minimizes the noise transfer within the package and improves input signal integrity. Each bank must have at least one VMV connection, and no VMV should be left unconnected. All I/Os in a bank run off the same VMVx supply. VMV is used to provide a quiet supply voltage to the input buffers of each I/O bank. VMVx can be 1.2 V, 1.5 V, 1.8 V, 2.5 V, or 3.3 V, nominal voltage. Unused I/O banks should have their corresponding VMV pins tied to GND. VMV and VCCI should be at the same voltage within a given I/O bank. Used VMV pins must be connected to the corresponding VCCI pins of the same bank (i.e., VMV0 to VCCIB0, VMV1 to VCCIB1, etc.).

VCCPLA/B/C/D/E/F**PLL Supply Voltage**

Supply voltage to analog PLL, nominally 1.5 V or 1.2 V.

When the PLLs are not used, the Microsemi Designer place-and-route tool automatically disables the unused PLLs to lower power consumption. The user should tie unused VCCPLx and VCOMPLx pins to ground. Microsemi recommends tying VCCPLx to VCC and using proper filtering circuits to decouple VCC noise from the PLLs. Refer to the PLL Power Supply Decoupling section of the "Clock Conditioning Circuits in IGLOO and ProASIC3 Devices" chapter in the *IGLOO nano FPGA Fabric User's Guide* for a complete board solution for the PLL analog power supply and ground.

There is one VCCPLF pin on IGLOO nano devices.

VCOMPLA/B/C/D/E/F**PLL Ground**

Ground to analog PLL power supplies. When the PLLs are not used, the Microsemi Designer place-and-route tool automatically disables the unused PLLs to lower power consumption. The user should tie unused VCCPLx and VCOMPLx pins to ground.

There is one VCOMPLF pin on IGLOO nano devices.

VJTAG**JTAG Supply Voltage**

Low power flash devices have a separate bank for the dedicated JTAG pins. The JTAG pins can be run at any voltage from 1.5 V to 3.3 V (nominal). Isolating the JTAG power supply in a separate I/O bank gives greater flexibility in supply selection and simplifies power supply and PCB design. If the JTAG

interface is neither used nor planned for use, the VJTAG pin together with the TRST pin could be tied to GND. It should be noted that VCC is required to be powered for JTAG operation; VJTAG alone is insufficient. If a device is in a JTAG chain of interconnected boards, the board containing the device can be powered down, provided both VJTAG and VCC to the part remain powered; otherwise, JTAG signals will not be able to transition the device, even in bypass mode.

Microsemi recommends that VPUMP and VJTAG power supplies be kept separate with independent filtering capacitors rather than supplying them from a common rail.

VPUMP Programming Supply Voltage

IGLOO nano devices support single-voltage ISP of the configuration flash and FlashROM. For programming, VPUMP should be 3.3 V nominal. During normal device operation, VPUMP can be left floating or can be tied (pulled up) to any voltage between 0 V and the VPUMP maximum. Programming power supply voltage (VPUMP) range is listed in the datasheet.

When the VPUMP pin is tied to ground, it will shut off the charge pump circuitry, resulting in no sources of oscillation from the charge pump circuitry.

For proper programming, 0.01 μ F and 0.33 μ F capacitors (both rated at 16 V) are to be connected in parallel across VPUMP and GND, and positioned as close to the FPGA pins as possible.

Microsemi recommends that VPUMP and VJTAG power supplies be kept separate with independent filtering capacitors rather than supplying them from a common rail.

User Pins

I/O User Input/Output

The I/O pin functions as an input, output, tristate, or bidirectional buffer. Input and output signal levels are compatible with the I/O standard selected.

During programming, I/Os become tristated and weakly pulled up to VCCI. With VCCI, VMV, and VCC supplies continuously powered up, when the device transitions from programming to operating mode, the I/Os are instantly configured to the desired user configuration.

Unused I/Os are configured as follows:

- Output buffer is disabled (with tristate value of high impedance)
- Input buffer is disabled (with tristate value of high impedance)
- Weak pull-up is programmed

GL Globals

GL I/Os have access to certain clock conditioning circuitry (and the PLL) and/or have direct access to the global network (spines). Additionally, the global I/Os can be used as regular I/Os, since they have identical capabilities. Unused GL pins are configured as inputs with pull-up resistors.

See more detailed descriptions of global I/O connectivity in the "Clock Conditioning Circuits in IGLOO and ProASIC3 Devices" chapter in the *IGLOO nano FPGA Fabric User's Guide*. All inputs labeled GC/GF are direct inputs into the quadrant clocks. For example, if GAA0 is used for an input, GAA1 and GAA2 are no longer available for input to the quadrant globals. All inputs labeled GC/GF are direct inputs into the chip-level globals, and the rest are connected to the quadrant globals. The inputs to the global network are multiplexed, and only one input can be used as a global input.

Refer to the "I/O Structures in nano Devices" chapter of the *IGLOO nano FPGA Fabric User's Guide* for an explanation of the naming of global pins.

FF Flash*Freeze Mode Activation Pin

Flash*Freeze is available on IGLOO nano devices. The FF pin is a dedicated input pin used to enter and exit Flash*Freeze mode. The FF pin is active low, has the same characteristics as a single-ended I/O, and must meet the maximum rise and fall times. When Flash*Freeze mode is not used in the design, the FF pin is available as a regular I/O.

When Flash*Freeze mode is used, the FF pin must not be left floating to avoid accidentally entering Flash*Freeze mode. While in Flash*Freeze mode, the Flash*Freeze pin should be constantly asserted.

The Flash*Freeze pin can be used with any single-ended I/O standard supported by the I/O bank in which the pin is located, and input signal levels compatible with the I/O standard selected. The FF pin

should be treated as a sensitive asynchronous signal. When defining pin placement and board layout, simultaneously switching outputs (SSOs) and their effects on sensitive asynchronous pins must be considered.

Unused FF or I/O pins are tristated with weak pull-up. This default configuration applies to both Flash*Freeze mode and normal operation mode. No user intervention is required.

Table 3-1 shows the Flash*Freeze pin location on the available packages for IGLOO nano devices. The Flash*Freeze pin location is independent of device (except for a PQ208 package), allowing migration to larger or smaller IGLOO nano devices while maintaining the same pin location on the board. Refer to the "Flash*Freeze Technology and Low Power Modes" chapter of the *IGLOO nano FPGA Fabric User's Guide* for more information on I/O states during Flash*Freeze mode.

Table 3-1 • Flash*Freeze Pin Locations for IGLOO nano Devices

Package	Flash*Freeze Pin
CS81/UC81	H2
QN48	14
QN68	18
VQ100	27
UC36	E2

JTAG Pins

Low power flash devices have a separate bank for the dedicated JTAG pins. The JTAG pins can be run at any voltage from 1.5 V to 3.3 V (nominal). VCC must also be powered for the JTAG state machine to operate, even if the device is in bypass mode; VJTAG alone is insufficient. Both VJTAG and VCC to the part must be supplied to allow JTAG signals to transition the device. Isolating the JTAG power supply in a separate I/O bank gives greater flexibility in supply selection and simplifies power supply and PCB design. If the JTAG interface is neither used nor planned for use, the VJTAG pin together with the TRST pin could be tied to GND.

TCK Test Clock

Test clock input for JTAG boundary scan, ISP, and UJTAG. The TCK pin does not have an internal pull-up/-down resistor. If JTAG is not used, Microsemi recommends tying off TCK to GND through a resistor placed close to the FPGA pin. This prevents JTAG operation in case TMS enters an undesired state.

Note that to operate at all VJTAG voltages, 500 Ω to 1 k Ω will satisfy the requirements. Refer to Table 3-2 for more information.

Table 3-2 • Recommended Tie-Off Values for the TCK and TRST Pins

VJTAG	Tie-Off Resistance ^{1,2}
VJTAG at 3.3 V	200 Ω to 1 k Ω
VJTAG at 2.5 V	200 Ω to 1 k Ω
VJTAG at 1.8 V	500 Ω to 1 k Ω
VJTAG at 1.5 V	500 Ω to 1 k Ω

Notes:

1. The TCK pin can be pulled-up or pulled-down.
2. The TRST pin is pulled-down.
3. Equivalent parallel resistance if more than one device is on the JTAG chain

Table 3-3 • TRST and TCK Pull-Down Recommendations

VJTAG	Tie-Off Resistance*
VJTAG at 3.3 V	200 Ω to 1 kΩ
VJTAG at 2.5 V	200 Ω to 1 kΩ
VJTAG at 1.8 V	500 Ω to 1 kΩ
VJTAG at 1.5 V	500 Ω to 1 kΩ

Note: Equivalent parallel resistance if more than one device is on the JTAG chain

TDI Test Data Input

Serial input for JTAG boundary scan, ISP, and UJTAG usage. There is an internal weak pull-up resistor on the TDI pin.

TDO Test Data Output

Serial output for JTAG boundary scan, ISP, and UJTAG usage.

TMS Test Mode Select

The TMS pin controls the use of the IEEE 1532 boundary scan pins (TCK, TDI, TDO, TRST). There is an internal weak pull-up resistor on the TMS pin.

TRST Boundary Scan Reset Pin

The TRST pin functions as an active-low input to asynchronously initialize (or reset) the boundary scan circuitry. There is an internal weak pull-up resistor on the TRST pin. If JTAG is not used, an external pull-down resistor could be included to ensure the test access port (TAP) is held in reset mode. The resistor values must be chosen from [Table 3-2](#) and must satisfy the parallel resistance value requirement. The values in [Table 3-2](#) correspond to the resistor recommended when a single device is used, and the equivalent parallel resistor when multiple devices are connected via a JTAG chain.

In critical applications, an upset in the JTAG circuit could allow entrance to an undesired JTAG state. In such cases, Microsemi recommends tying off TRST to GND through a resistor placed close to the FPGA pin.

Note that to operate at all VJTAG voltages, 500 Ω to 1 kΩ will satisfy the requirements.

Special Function Pins

NC No Connect

This pin is not connected to circuitry within the device. These pins can be driven to any voltage or can be left floating with no effect on the operation of the device.

DC Do Not Connect

This pin should not be connected to any signals on the PCB. These pins should be left unconnected.

Packaging

Semiconductor technology is constantly shrinking in size while growing in capability and functional integration. To enable next-generation silicon technologies, semiconductor packages have also evolved to provide improved performance and flexibility.

Microsemi consistently delivers packages that provide the necessary mechanical and environmental protection to ensure consistent reliability and performance. Microsemi IC packaging technology efficiently supports high-density FPGAs with large-pin-count Ball Grid Arrays (BGAs), but is also flexible enough to accommodate stringent form factor requirements for Chip Scale Packaging (CSP). In addition, Microsemi offers a variety of packages designed to meet your most demanding application and economic requirements for today's embedded and mobile systems.

Related Documents

User Guides

IGLOO nano FPGA Fabric User's Guide

Packaging Documents

The following documents provide packaging information and device selection for low power flash devices.

Product Catalog

FPGA and SoC Product Catalog

Lists devices currently recommended for new designs and the packages available for each member of the family. Use this document or the datasheet tables to determine the best package for your design, and which package drawing to use.

Package Mechanical Drawings

This document contains the package mechanical drawings for all packages currently or previously supplied by Microsemi. Use the bookmarks to navigate to the package mechanical drawings.

Additional packaging materials are on the Microsemi SoC Products Group website:

<http://www.microsemi.com/soc/products/solutions/package/docs.aspx>.

4 – Package Pin Assignments

UC36

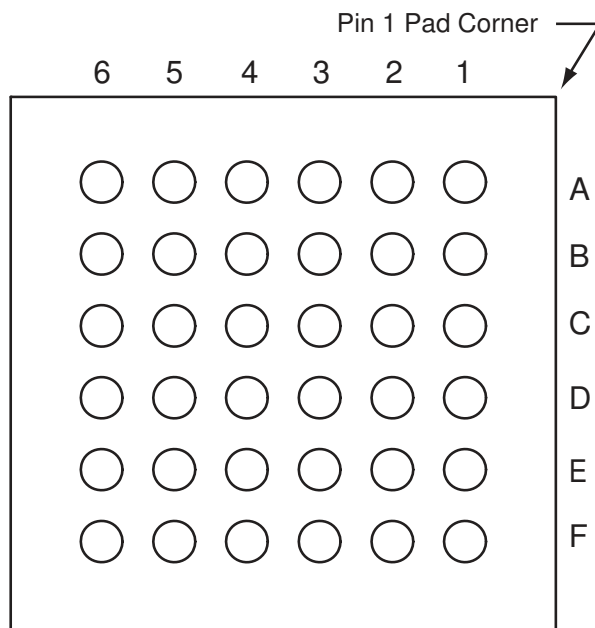

Note: This is the bottom view of the package.

Note

For Package Manufacturing and Environmental information, visit the Resource Center at <http://www.microsemi.com/soc/products/solutions/package/docs.aspx>.

UC36	
Pin Number	AGLN010 Function
A1	IO21RSB1
A2	IO18RSB1
A3	IO13RSB1
A4	GDC0/IO00RSB0
A5	IO06RSB0
A6	GDA0/IO04RSB0
B1	GEC0/IO37RSB1
B2	IO20RSB1
B3	IO15RSB1
B4	IO09RSB0
B5	IO08RSB0
B6	IO07RSB0
C1	IO22RSB1
C2	GEA0/IO34RSB1
C3	GND
C4	GND
C5	VCCIB0
C6	IO02RSB0
D1	IO33RSB1
D2	VCCIB1
D3	VCC
D4	VCC
D5	IO10RSB0
D6	IO11RSB0
E1	IO32RSB1
E2	FF/IO31RSB1
E3	TCK
E4	VPUMP
E5	TRST
E6	VJTAG
F1	IO29RSB1
F2	IO25RSB1
F3	IO23RSB1
F4	TDI

UC36	
Pin Number	AGLN010 Function
F5	TMS
F6	TDO

UC81

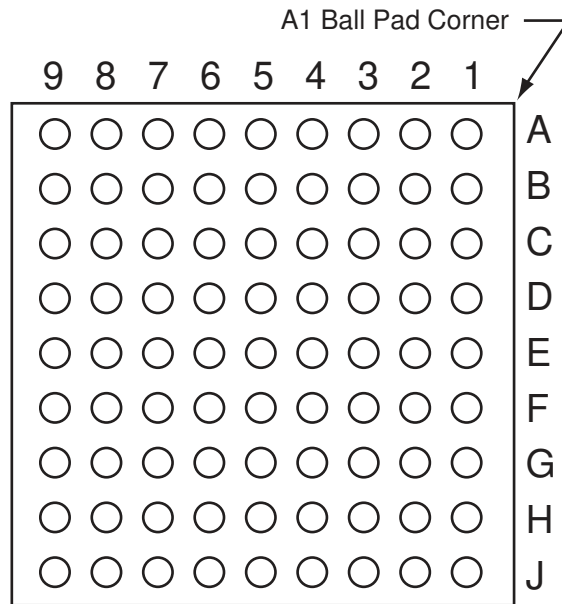

Note: This is the bottom view of the package.

Note

For Package Manufacturing and Environmental information, visit the Resource Center at <http://www.microsemi.com/soc/products/solutions/package/docs.aspx>.

CS81

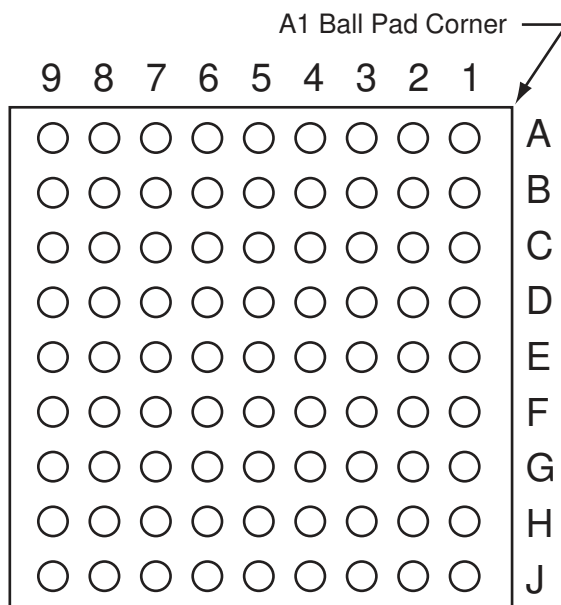

Note: This is the bottom view of the package.

Note

For Package Manufacturing and Environmental information, visit the Resource Center at <http://www.microsemi.com/soc/products/solutions/package/docs.aspx>.

CS81		CS81		CS81	
Pin Number	AGLN020 Function	Pin Number	AGLN020 Function	Pin Number	AGLN020 Function
A1	IO64RSB2	E1	GEC0/IO48RSB2	J1	IO38RSB1
A2	IO54RSB2	E2	GEA0/IO47RSB2	J2	IO37RSB1
A3	IO57RSB2	E3	NC	J3	IO33RSB1
A4	IO36RSB1	E4	VCCIB1	J4	IO30RSB1
A5	IO32RSB1	E5	VCC	J5	IO27RSB1
A6	IO24RSB1	E6	VCCIB0	J6	IO23RSB1
A7	IO20RSB1	E7	NC	J7	TCK
A8	IO04RSB0	E8	GDA0/IO15RSB0	J8	TMS
A9	IO08RSB0	E9	GDC0/IO14RSB0	J9	VPUMP
B1	IO59RSB2	F1	IO46RSB2		
B2	IO55RSB2	F2	IO45RSB2		
B3	IO62RSB2	F3	NC		
B4	IO34RSB1	F4	GND		
B5	IO28RSB1	F5	VCCIB1		
B6	IO22RSB1	F6	NC		
B7	IO18RSB1	F7	NC		
B8	IO00RSB0	F8	IO16RSB0		
B9	IO03RSB0	F9	IO17RSB0		
C1	IO51RSB2	G1	IO43RSB2		
C2	IO50RSB2	G2	IO42RSB2		
C3	NC	G3	IO41RSB2		
C4	NC	G4	IO31RSB1		
C5	NC	G5	NC		
C6	NC	G6	IO21RSB1		
C7	NC	G7	NC		
C8	IO10RSB0	G8	VJTAG		
C9	IO07RSB0	G9	TRST		
D1	IO49RSB2	H1	IO40RSB2		
D2	IO44RSB2	H2	FF/IO39RSB1		
D3	NC	H3	IO35RSB1		
D4	VCC	H4	IO29RSB1		
D5	VCCIB2	H5	IO26RSB1		
D6	GND	H6	IO25RSB1		
D7	NC	H7	IO19RSB1		
D8	IO13RSB0	H8	TDI		
D9	IO12RSB0	H9	TDO		

CS81	
Pin Number	AGLN060 Function
A1	GAA0/IO02RSB0
A2	GAA1/IO03RSB0
A3	GAC0/IO06RSB0
A4	IO09RSB0
A5	IO13RSB0
A6	IO18RSB0
A7	GBB0/IO21RSB0
A8	GBA1/IO24RSB0
A9	GBA2/IO25RSB0
B1	GAA2/IO95RSB1
B2	GAB0/IO04RSB0
B3	GAC1/IO07RSB0
B4	IO08RSB0
B5	IO15RSB0
B6	GBC0/IO19RSB0
B7	GBB1/IO22RSB0
B8	IO26RSB0
B9	GBB2/IO27RSB0
C1	GAB2/IO93RSB1
C2	IO94RSB1
C3	GND
C4	IO10RSB0
C5	IO17RSB0
C6	GND
C7	GBA0/IO23RSB0
C8	GBC2/IO29RSB0
C9	IO31RSB0
D1	GAC2/IO91RSB1
D2	IO92RSB1
D3	GFA2/IO80RSB1
D4	VCC
D5	VCCIB0
D6	GND
D7	GCC2/IO43RSB0
D8	GCC1/IO35RSB0
D9	GCC0/IO36RSB0

CS81	
Pin Number	AGLN060 Function
E1	GFB0/IO83RSB1
E2	GFB1/IO84RSB1
E3	GFA1/IO81RSB1
E4	VCCIB1
E5	VCC
E6	VCCIB0
E7	GCA1/IO39RSB0
E8	GCA0/IO40RSB0
E9	GCB2/IO42RSB0
F1 ¹	VCCPLF
F2 ¹	VCOMPLF
F3	GND
F4	GND
F5	VCCIB1
F6	GND
F7	GDA1/IO49RSB0
F8	GDC1/IO45RSB0
F9	GDC0/IO46RSB0
G1	GEA0/IO69RSB1
G2	GEC1/IO74RSB1
G3	GEB1/IO72RSB1
G4	IO63RSB1
G5	IO60RSB1
G6	IO54RSB1
G7	GDB2/IO52RSB1
G8	VJTAG
G9	TRST
H1	GEA1/IO70RSB1
H2	FF/GEB2/IO67RSB1
H3	IO65RSB1
H4	IO62RSB1
H5	IO59RSB1
H6	IO56RSB1
H7 ²	GDA2/IO51RSB1
H8	TDI
H9	TDO

CS81	
Pin Number	AGLN060 Function
J1	GEA2/IO68RSB1
J2	GEC2/IO66RSB1
J3	IO64RSB1
J4	IO61RSB1
J5	IO58RSB1
J6	IO55RSB1
J7	TCK
J8	TMS
J9	VPUMP

CS81	
Pin Number	AGLN125 Function
A1	GAA0/IO00RSB0
A2	GAA1/IO01RSB0
A3	GAC0/IO04RSB0
A4	IO13RSB0
A5	IO22RSB0
A6	IO32RSB0
A7	GBB0/IO37RSB0
A8	GBA1/IO40RSB0
A9	GBA2/IO41RSB0
B1	GAA2/IO132RSB1
B2	GAB0/IO02RSB0
B3	GAC1/IO05RSB0
B4	IO11RSB0
B5	IO25RSB0
B6	GBC0/IO35RSB0
B7	GBB1/IO38RSB0
B8	IO42RSB0
B9	GBB2/IO43RSB0
C1	GAB2/IO130RSB1
C2	IO131RSB1
C3	GND
C4	IO15RSB0
C5	IO28RSB0
C6	GND
C7	GBA0/IO39RSB0
C8	GBC2/IO45RSB0
C9	IO47RSB0
D1	GAC2/IO128RSB1
D2	IO129RSB1
D3	GFA2/IO117RSB1
D4	VCC
D5	VCCIB0
D6	GND
D7	GCC2/IO59RSB0
D8	GCC1/IO51RSB0
D9	GCC0/IO52RSB0

CS81	
Pin Number	AGLN125 Function
E1	GFB0/IO120RSB1
E2	GFB1/IO121RSB1
E3	GFA1/IO118RSB1
E4	VCCIB1
E5	VCC
E6	VCCIB0
E7	GCA0/IO56RSB0
E8	GCA1/IO55RSB0
E9	GCB2/IO58RSB0
F1*	VCCPLF
F2*	VCOMPLF
F3	GND
F4	GND
F5	VCCIB1
F6	GND
F7	GDA1/IO65RSB0
F8	GDC1/IO61RSB0
F9	GDC0/IO62RSB0
G1	GEA0/IO104RSB1
G2	GEC0/IO108RSB1
G3	GEB1/IO107RSB1
G4	IO96RSB1
G5	IO92RSB1
G6	IO72RSB1
G7	GDB2/IO68RSB1
G8	VJTAG
G9	TRST
H1	GEA1/IO105RSB1
H2	FF/GEB2/IO102RSB1
H3	IO99RSB1
H4	IO94RSB1
H5	IO91RSB1
H6	IO81RSB1
H7	GDA2/IO67RSB1
H8	TDI
H9	TDO

CS81	
Pin Number	AGLN125 Function
J1	GEA2/IO103RSB1
J2	GEC2/IO101RSB1
J3	IO97RSB1
J4	IO93RSB1
J5	IO90RSB1
J6	IO78RSB1
J7	TCK
J8	TMS
J9	VPUMP

CS81	
Pin Number	AGLN250 Function
A1	GAA0/IO00RSB0
A2	GAA1/IO01RSB0
A3	GAC0/IO04RSB0
A4	IO07RSB0
A5	IO09RSB0
A6	IO12RSB0
A7	GBB0/IO16RSB0
A8	GBA1/IO19RSB0
A9	GBA2/IO20RSB1
B1	GAA2/IO67RSB3
B2	GAB0/IO02RSB0
B3	GAC1/IO05RSB0
B4	IO06RSB0
B5	IO10RSB0
B6	GBC0/IO14RSB0
B7	GBB1/IO17RSB0
B8	IO21RSB1
B9	GBB2/IO22RSB1
C1	GAB2/IO65RSB3
C2	IO66RSB3
C3	GND
C4	IO08RSB0
C5	IO11RSB0
C6	GND
C7	GBA0/IO18RSB0
C8	GBC2/IO23RSB1
C9	IO24RSB1
D1	GAC2/IO63RSB3
D2	IO64RSB3
D3	GFA2/IO56RSB3
D4	VCC
D5	VCCIB0
D6	GND
D7	IO30RSB1
D8	GCC1/IO25RSB1
D9	GCC0/IO26RSB1

CS81	
Pin Number	AGLN250 Function
E1	GFB0/IO59RSB3
E2	GFB1/IO60RSB3
E3	GFA1/IO58RSB3
E4	VCCIB3
E5	VCC
E6	VCCIB1
E7	GCA0/IO28RSB1
E8	GCA1/IO27RSB1
E9	GCB2/IO29RSB1
F1	VCCPLF
F2	VCOMPLF
F3	GND
F4	GND
F5	VCCIB2
F6	GND
F7	GDA1/IO33RSB1
F8	GDC1/IO31RSB1
F9	GDC0/IO32RSB1
G1	GEA0/IO51RSB3
G2	GEC1/IO54RSB3
G3	GEC0/IO53RSB3
G4	IO45RSB2
G5	IO42RSB2
G6	IO37RSB2
G7	GDB2/IO35RSB2
G8	VJTAG
G9	TRST
H1	GEA1/IO52RSB3
H2	FF/GEB2/IO49RSB2
H3	IO47RSB2
H4	IO44RSB2
H5	IO41RSB2
H6	IO39RSB2
H7	GDA2/IO34RSB2
H8	TDI
H9	TDO

CS81	
Pin Number	AGLN250 Function
J1	GEA2/IO50RSB2
J2	GEC2/IO48RSB2
J3	IO46RSB2
J4	IO43RSB2
J5	IO40RSB2
J6	IO38RSB2
J7	TCK
J8	TMS
J9	VPUMP

QN48

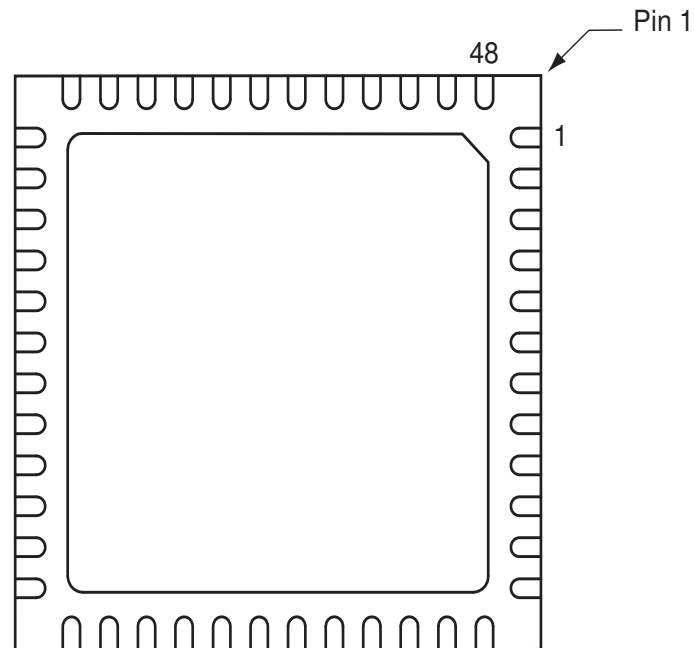

Notes:

1. This is the bottom view of the package.
 2. The die attach paddle of the package is tied to ground (GND).
-

Note

For Package Manufacturing and Environmental information, visit the Resource Center at <http://www.microsemi.com/soc/products/solutions/package/docs.aspx>.

Notes:

1. Pin numbers F1 and F2 must be connected to ground because a PLL is not supported for AGLN060-CS81.
2. The bus hold attribute (hold previous I/O state in Flash*Freeze mode) is not supported for pin H7 in AGLN060-CS81.

QN48		QN48	
Pin Number	AGLN010 Function	Pin Number	AGLN010 Function
1	GEC0/IO37RSB1	34	GND
2	IO36RSB1	35	VCC
3	GEA0/IO34RSB1	36	IO07RSB0
4	IO22RSB1	37	IO06RSB0
5	GND	38	GDA0/IO05RSB0
6	VCCIB1	39	IO03RSB0
7	IO24RSB1	40	GDC0/IO01RSB0
8	IO33RSB1	41	IO12RSB1
9	IO26RSB1	42	IO13RSB1
10	IO32RSB1	43	IO15RSB1
11	IO27RSB1	44	IO16RSB1
12	IO29RSB1	45	IO18RSB1
13	IO30RSB1	46	IO19RSB1
14	FF/IO31RSB1	47	IO20RSB1
15	IO28RSB1	48	IO21RSB1
16	IO25RSB1		
17	IO23RSB1		
18	VCC		
19	VCCIB1		
20	IO17RSB1		
21	IO14RSB1		
22	TCK		
23	TDI		
24	TMS		
25	VPUMP		
26	TDO		
27	TRST		
28	VJTAG		
29	IO11RSB0		
30	IO10RSB0		
31	IO09RSB0		
32	IO08RSB0		
33	VCCIB0		

Notes:

1. Pin numbers F1 and F2 must be connected to ground because a PLL is not supported for AGLN060Z-CS81.
2. The bus hold attribute (hold previous I/O state in Flash*Freeze mode) is not supported for pin H7 in AGLN060Z-CS81.

QN68

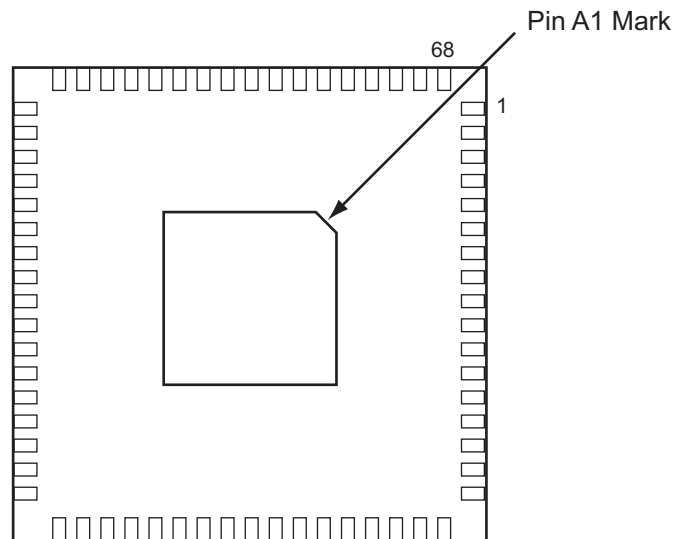

Notes:

1. This is the bottom view of the package.
 2. The die attach paddle of the package is tied to ground (GND).
-

Note

For Package Manufacturing and Environmental information, visit the Resource Center at <http://www.microsemi.com/soc/products/solutions/package/docs.aspx>.

Note: * Pin numbers F1 and F2 must be connected to ground because a PLL is not supported for AGLN125-CS81.

QN68		QN68	
Pin Number	AGLN020 Function	Pin Number	AGLN020 Function
1	IO60RSB2	36	TDO
2	IO54RSB2	37	TRST
3	IO52RSB2	38	VJTAG
4	IO50RSB2	39	IO17RSB0
5	IO49RSB2	40	IO16RSB0
6	GEC0/IO48RSB2	41	GDA0/IO15RSB0
7	GEA0/IO47RSB2	42	GDC0/IO14RSB0
8	VCC	43	IO13RSB0
9	GND	44	VCCIB0
10	VCCIB2	45	GND
11	IO46RSB2	46	VCC
12	IO45RSB2	47	IO12RSB0
13	IO44RSB2	48	IO11RSB0
14	IO43RSB2	49	IO09RSB0
15	IO42RSB2	50	IO05RSB0
16	IO41RSB2	51	IO00RSB0
17	IO40RSB2	52	IO07RSB0
18	FF/IO39RSB1	53	IO03RSB0
19	IO37RSB1	54	IO18RSB1
20	IO35RSB1	55	IO20RSB1
21	IO33RSB1	56	IO22RSB1
22	IO31RSB1	57	IO24RSB1
23	IO30RSB1	58	IO28RSB1
24	VCC	59	NC
25	GND	60	GND
26	VCCIB1	61	NC
27	IO27RSB1	62	IO32RSB1
28	IO25RSB1	63	IO34RSB1
29	IO23RSB1	64	IO36RSB1
30	IO21RSB1	65	IO61RSB2
31	IO19RSB1	66	IO58RSB2
32	TCK	67	IO56RSB2
33	TDI	68	IO63RSB2
34	TMS		
35	VPUMP		

Note: * Pin numbers F1 and F2 must be connected to ground because a PLL is not supported for AGLN125Z-CS81.

VQ100

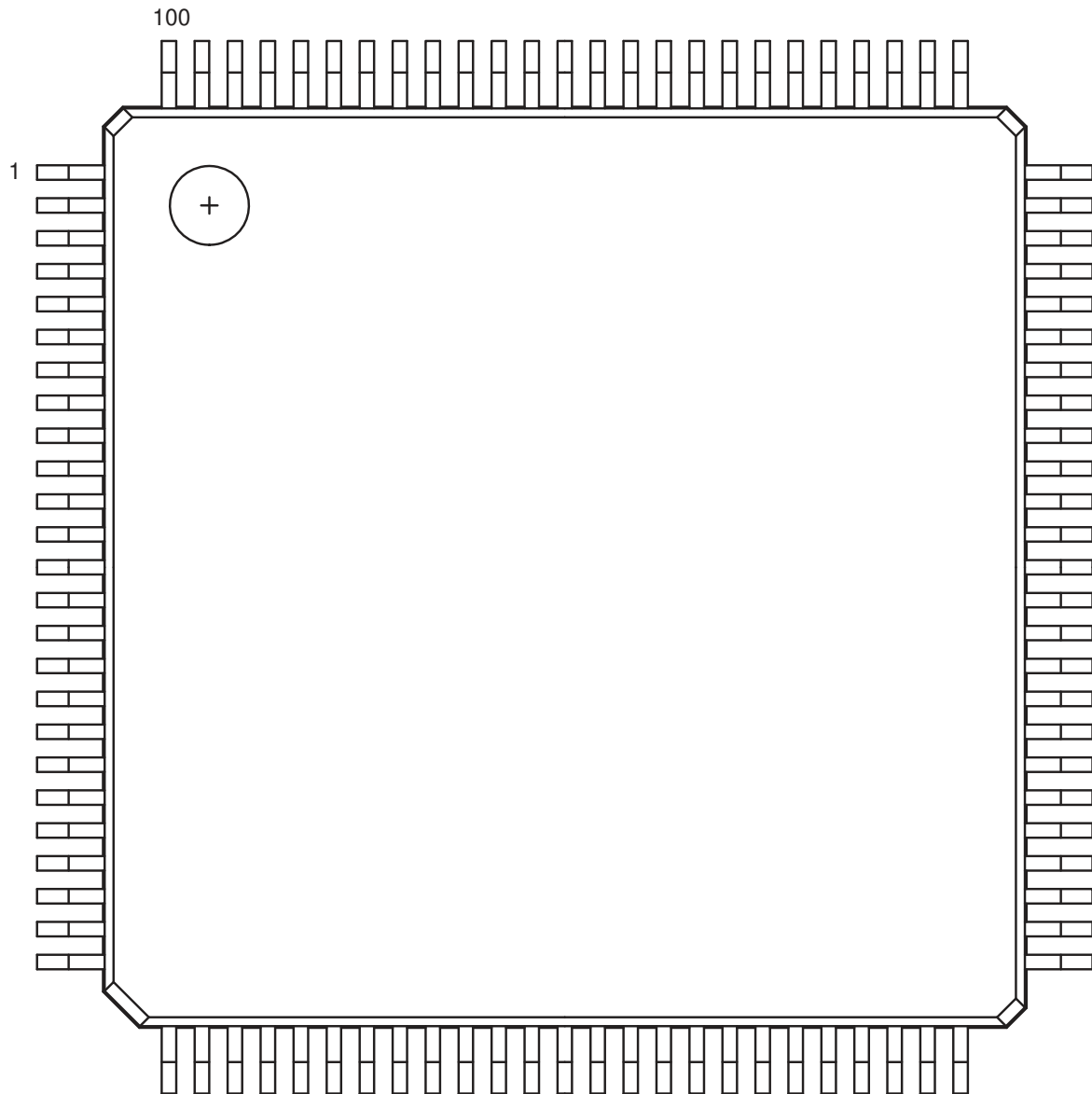

Note: This is the top view of the package.

Note

For Package Manufacturing and Environmental information, visit the Resource Center at <http://www.microsemi.com/soc/products/solutions/package/docs.aspx>.

Note: * Pin numbers F1 and F2 must be connected to ground because a PLL is not supported for AGLN250-CS81.

VQ100		VQ100		VQ100	
Pin Number	AGLN060 Function	Pin Number	AGLN060 Function	Pin Number	AGLN060 Function
1	GND	37	VCC	73	GBA2/IO25RSB0
2	GAA2/IO51RSB1	38	GND	74	VMV0
3	IO52RSB1	39	VCCIB1	75	GNDQ
4	GAB2/IO53RSB1	40	IO60RSB1	76	GBA1/IO24RSB0
5	IO95RSB1	41	IO59RSB1	77	GBA0/IO23RSB0
6	GAC2/IO94RSB1	42	IO58RSB1	78	GBB1/IO22RSB0
7	IO93RSB1	43	IO57RSB1	79	GBB0/IO21RSB0
8	IO92RSB1	44	GDC2/IO56RSB1	80	GBC1/IO20RSB0
9	GND	45*	GDB2/IO55RSB1	81	GBC0/IO19RSB0
10	GFB1/IO87RSB1	46	GDA2/IO54RSB1	82	IO18RSB0
11	GFB0/IO86RSB1	47	TCK	83	IO17RSB0
12	VCOMPLF	48	TDI	84	IO15RSB0
13	GFA0/IO85RSB1	49	TMS	85	IO13RSB0
14	VCCPLF	50	VMV1	86	IO11RSB0
15	GFA1/IO84RSB1	51	GND	87	VCCIB0
16	GFA2/IO83RSB1	52	VPUMP	88	GND
17	VCC	53	NC	89	VCC
18	VCCIB1	54	TDO	90	IO10RSB0
19	GEC1/IO77RSB1	55	TRST	91	IO09RSB0
20	GEB1/IO75RSB1	56	VJTAG	92	IO08RSB0
21	GEB0/IO74RSB1	57	GDA1/IO49RSB0	93	GAC1/IO07RSB0
22	GEA1/IO73RSB1	58	GDC0/IO46RSB0	94	GAC0/IO06RSB0
23	GEA0/IO72RSB1	59	GDC1/IO45RSB0	95	GAB1/IO05RSB0
24	VMV1	60	GCC2/IO43RSB0	96	GAB0/IO04RSB0
25	GNDQ	61	GCB2/IO42RSB0	97	GAA1/IO03RSB0
26	GEA2/IO71RSB1	62	GCA0/IO40RSB0	98	GAA0/IO02RSB0
27	FF/GEB2/IO70RSB1	63	GCA1/IO39RSB0	99	IO01RSB0
28	GEC2/IO69RSB1	64	GCC0/IO36RSB0	100	IO00RSB0
29	IO68RSB1	65	GCC1/IO35RSB0		
30	IO67RSB1	66	VCCIB0		
31	IO66RSB1	67	GND		
32	IO65RSB1	68	VCC		
33	IO64RSB1	69	IO31RSB0		
34	IO63RSB1	70	GBC2/IO29RSB0		
35	IO62RSB1	71	GBB2/IO27RSB0		
36	IO61RSB1	72	IO26RSB0		

Note: * Pin numbers F1 and F2 must be connected to ground because a PLL is not supported for AGLN250Z-CS81.

VQ100	
Pin Number	AGLN125 Function
1	GND
2	GAA2/IO67RSB1
3	IO68RSB1
4	GAB2/IO69RSB1
5	IO132RSB1
6	GAC2/IO131RSB1
7	IO130RSB1
8	IO129RSB1
9	GND
10	GFB1/IO124RSB1
11	GFB0/IO123RSB1
12	VCOMPLF
13	GFA0/IO122RSB1
14	VCCPLF
15	GFA1/IO121RSB1
16	GFA2/IO120RSB1
17	VCC
18	VCCIB1
19	GEC0/IO111RSB1
20	GEB1/IO110RSB1
21	GEB0/IO109RSB1
22	GEA1/IO108RSB1
23	GEA0/IO107RSB1
24	VMV1
25	GNDQ
26	GEA2/IO106RSB1
27	FF/GEB2/IO105RSB1
28	GEC2/IO104RSB1
29	IO102RSB1
30	IO100RSB1
31	IO99RSB1
32	IO97RSB1
33	IO96RSB1
34	IO95RSB1
35	IO94RSB1
36	IO93RSB1

VQ100	
Pin Number	AGLN125 Function
37	VCC
38	GND
39	VCCIB1
40	IO87RSB1
41	IO84RSB1
42	IO81RSB1
43	IO75RSB1
44	GDC2/IO72RSB1
45	GDB2/IO71RSB1
46	GDA2/IO70RSB1
47	TCK
48	TDI
49	TMS
50	VMV1
51	GND
52	VPUMP
53	NC
54	TDO
55	TRST
56	VJTAG
57	GDA1/IO65RSB0
58	GDC0/IO62RSB0
59	GDC1/IO61RSB0
60	GCC2/IO59RSB0
61	GCB2/IO58RSB0
62	GCA0/IO56RSB0
63	GCA1/IO55RSB0
64	GCC0/IO52RSB0
65	GCC1/IO51RSB0
66	VCCIB0
67	GND
68	VCC
69	IO47RSB0
70	GBC2/IO45RSB0
71	GBB2/IO43RSB0
72	IO42RSB0

VQ100	
Pin Number	AGLN125 Function
73	GBA2/IO41RSB0
74	VMV0
75	GNDQ
76	GBA1/IO40RSB0
77	GBA0/IO39RSB0
78	GBB1/IO38RSB0
79	GBB0/IO37RSB0
80	GBC1/IO36RSB0
81	GBC0/IO35RSB0
82	IO32RSB0
83	IO28RSB0
84	IO25RSB0
85	IO22RSB0
86	IO19RSB0
87	VCCIB0
88	GND
89	VCC
90	IO15RSB0
91	IO13RSB0
92	IO11RSB0
93	IO09RSB0
94	IO07RSB0
95	GAC1/IO05RSB0
96	GAC0/IO04RSB0
97	GAB1/IO03RSB0
98	GAB0/IO02RSB0
99	GAA1/IO01RSB0
100	GAA0/IO00RSB0

VQ100	
Pin Number	AGLN250 Function
1	GND
2	GAA2/IO67RSB3
3	IO66RSB3
4	GAB2/IO65RSB3
5	IO64RSB3
6	GAC2/IO63RSB3
7	IO62RSB3
8	IO61RSB3
9	GND
10	GFB1/IO60RSB3
11	GFB0/IO59RSB3
12	VCOMPLF
13	GFA0/IO57RSB3
14	VCCPLF
15	GFA1/IO58RSB3
16	GFA2/IO56RSB3
17	VCC
18	VCCIB3
19	GFC2/IO55RSB3
20	GEC1/IO54RSB3
21	GEC0/IO53RSB3
22	GEA1/IO52RSB3
23	GEA0/IO51RSB3
24	VMV3
25	GNDQ
26	GEA2/IO50RSB2
27	FF/GEB2/IO49RSB2
28	GEC2/IO48RSB2
29	IO47RSB2
30	IO46RSB2
31	IO45RSB2
32	IO44RSB2
33	IO43RSB2
34	IO42RSB2
35	IO41RSB2
36	IO40RSB2

VQ100	
Pin Number	AGLN250 Function
37	VCC
38	GND
39	VCCIB2
40	IO39RSB2
41	IO38RSB2
42	IO37RSB2
43	GDC2/IO36RSB2
44	GDB2/IO35RSB2
45	GDA2/IO34RSB2
46	GNDQ
47	TCK
48	TDI
49	TMS
50	VMV2
51	GND
52	VPUMP
53	NC
54	TDO
55	TRST
56	VJTAG
57	GDA1/IO33RSB1
58	GDC0/IO32RSB1
59	GDC1/IO31RSB1
60	IO30RSB1
61	GCB2/IO29RSB1
62	GCA1/IO27RSB1
63	GCA0/IO28RSB1
64	GCC0/IO26RSB1
65	GCC1/IO25RSB1
66	VCCIB1
67	GND
68	VCC
69	IO24RSB1
70	GBC2/IO23RSB1
71	GBB2/IO22RSB1
72	IO21RSB1

VQ100	
Pin Number	AGLN250 Function
73	GBA2/IO20RSB1
74	VMV1
75	GNDQ
76	GBA1/IO19RSB0
77	GBA0/IO18RSB0
78	GBB1/IO17RSB0
79	GBB0/IO16RSB0
80	GBC1/IO15RSB0
81	GBC0/IO14RSB0
82	IO13RSB0
83	IO12RSB0
84	IO11RSB0
85	IO10RSB0
86	IO09RSB0
87	VCCIB0
88	GND
89	VCC
90	IO08RSB0
91	IO07RSB0
92	IO06RSB0
93	GAC1/IO05RSB0
94	GAC0/IO04RSB0
95	GAB1/IO03RSB0
96	GAB0/IO02RSB0
97	GAA1/IO01RSB0
98	GAA0/IO00RSB0
99	GNDQ
100	VMV0

5 – Datasheet Information

List of Changes

The following table lists critical changes that were made in each version of the IGLOO nano datasheet.

Revision	Changes	Page
Revision 20 (October 2019)	Modified the table under the "Features and Benefits" section by removing references to AGLN015.	1-I
	Modified the table under the "I/Os Per Package" section by removing references to AGLN015.	1-II
	Modified the "IGLOO nano Device Status" section.	1-III
	Modified the "IGLOO nano Ordering Information" section by removing references to AGLN015.	1-IV
	Removed the "Devices Not Recommended For New Designs" section.	
	Modified the "Device Marking" section.	1-V
	Removed the "IGLOO nano Products Available in the Z Feature Grade" section.	
	Modified the "Temperature Grade Offerings" section.	1-V
	Removed reference of AGLN015 from the Figure 1-2.	1-4
	Modified "Quiescent Supply Current (IDD) Characteristics, IGLOO nano Flash*Freeze Mode*" table by removing references to AGLN015.	2-7
	Modified "Quiescent Supply Current (IDD) Characteristics, IGLOO nano Sleep Mode*" table by removing references to AGLN015.	2-8
	Modified "Quiescent Supply Current (IDD) Characteristics, IGLOO nano Sleep Mode*" table by removing references to AGLN015.	2-8
	Modified "Quiescent Supply Current (IDD), No IGLOO nano Flash*Freeze Mode ¹ " table by removing references to AGLN015.	2-8
	Modified "Different Components Contributing to Dynamic Power Consumption in IGLOO nano Devices" table by removing references to AGLN015.	2-10
	Modified "Different Components Contributing to the Static Power Consumption in IGLOO nano Devices" table by removing references to AGLN015.	2-10
	Modified "Different Components Contributing to Dynamic Power Consumption in IGLOO nano Devices" table by removing references to AGLN015.	2-11
	Modified "Different Components Contributing to the Static Power Consumption in IGLOO nano Devices" table by removing references to AGLN015.	2-11
	Modified the note under the "DDR Module Specifications" section by removing reference to AGLN015.	2-51
	Modified the "Global Tree Timing Characteristics" section by removing references to AGLN015.	2-64
	Modified the notes in the "Clock Conditioning Circuits" section by removing reference to AGLN015.	2-70
Modified the "UC81" section.	4-3	
Modified the "CS81" section.	4-4	
Modified the "QN48" section.	4-9	
Modified the "QN68" section.	4-11	
Modified the "VQ100" section.	4-13	

Revision	Changes	Page
Revision 19 (October 2015)	Modified the note to include device/package obsolescence information in "Features and Benefits" section (SAR 69724).	1-1
	Added a note under Security Feature "Y" in "IGLOO nano Ordering Information" section (SAR 70553).	1-IV
	Modified AGLN250 pin assignment table to match with I/O Attribute Editor tool from Libero in "CS81" Package (SAR 59049).	4-4
	Modified the nominal area to 25 for CS81 Package in Table 1 (SAR 71127).	1-II
	Modified the title of AGLN125Z pin assignment table for "CS81" Package (SAR 71127).	4-4
Revision 18 (November 2013)	Modified the "Device Marking" section and updated Figure 1 • Example of Device Marking for Small Form Factor Packages to reflect updates suggested per CN1004 published on 5/10/2010 (SAR 52036).	V
Revision 17 (May 2013)	Deleted details related to Ambient temperature from "Enhanced Commercial Temperature Range", "IGLOO nano Ordering Information", "Temperature Grade Offerings", and Table 2-2 • Recommended Operating Conditions ¹ to remove ambiguities arising due to the same, and modified Note 2 (SAR 47063).	I, IV, V, and 2-2
Revision 16 (December 2012)	The "IGLOO nano Ordering Information" section has been updated to mention "Y" as "Blank" mentioning "Device Does Not Include License to Implement IP Based on the Cryptography Research, Inc. (CRI) Patent Portfolio" (SAR 43174).	IV
	The note in Table 2-99 • IGLOO nano CCC/PLL Specification and Table 2-100 • IGLOO nano CCC/PLL Specification referring the reader to SmartGen was revised to refer instead to the online help associated with the core (SAR 42565).	2-70, 2-71
	Live at Power-Up (LAPU) has been replaced with 'Instant On'.	NA
Revision 15 (September 2012)	The status of the AGLN125 device has been modified from 'Advance' to 'Production' in the "IGLOO nano Device Status" section (SAR 41416).	III
	Libero Integrated Design Environment (IDE) was changed to Libero System-on-Chip (SoC) throughout the document (SAR 40274).	NA
Revision 14 (September 2012)	The "Security" section was modified to clarify that Microsemi does not support read-back of programmed data.	1-2
Revision 13 (June 2012)	Figure Figure 2-34 • FIFO Read and Figure 2-35 • FIFO Write have been added (SAR 34842).	2-82
	The following sentence was removed from the "VMVx I/O Supply Voltage (quiet)" section in the "Pin Descriptions" section: "Within the package, the VMV plane is decoupled from the simultaneous switching noise originating from the output buffer VCCI domain" and replaced with "Within the package, the VMV plane biases the input stage of the I/Os in the I/O banks" (SAR 38319). The datasheet mentions that "VMV pins must be connected to the corresponding VCCI pins" for an ESD enhancement.	3-1
Revision 12 (March 2012)	The "In-System Programming (ISP) and Security" section and "Security" section were revised to clarify that although no existing security measures can give an absolute guarantee, Microsemi FPGAs implement the best security available in the industry (SAR 34663).	I, 1-2
	Notes indicating that AGLN015 is not recommended for new designs have been added (SAR 35759). Notes indicating that nano-Z devices are not recommended for new designs have been added. The "Devices Not Recommended For New Designs" section is new (SAR 36759).	III, IV

Revision	Changes	Page
Revision 12 (continued)	The Y security option and Licensed DPA Logo were added to the "IGLOO nano Ordering Information" section. The trademarked Licensed DPA Logo identifies that a product is covered by a DPA counter-measures license from Cryptography Research (SAR 34722).	IV
	The following sentence was removed from the "Advanced Architecture" section: "In addition, extensive on-chip programming circuitry enables rapid, single-voltage (3.3 V) programming of IGLOO nano devices via an IEEE 1532 JTAG interface" (SAR 34683).	1-3
	The "Specifying I/O States During Programming" section is new (SAR 34694).	1-9
	The reference to guidelines for global spines and VersaTile rows, given in the "Global Clock Contribution—P _{CLOCK} " section, was corrected to the "Spine Architecture" section of the Global Resources chapter in the <i>IGLOO nano FPGA Fabric User's Guide</i> (SAR 34732).	2-12
	Figure 2-4 has been modified for DIN waveform; the Rise and Fall time label has been changed to tDIN (37106).	2-16
	The AC Loading figures in the "Single-Ended I/O Characteristics" section were updated to match tables in the "Summary of I/O Timing Characteristics – Default I/O Software Settings" section (SAR 34885).	2-26, 2-20
	The notes regarding drive strength in the "Summary of I/O Timing Characteristics – Default I/O Software Settings" section, "3.3 V LVCMOS Wide Range" section and "1.2 V LVCMOS Wide Range" section tables were revised for clarification. They now state that the minimum drive strength for the default software configuration when run in wide range is $\pm 100 \mu\text{A}$. The drive strength displayed in software is supported in normal range only. For a detailed I/V curve, refer to the IBIS models (SAR 34765).	2-20, 2-29, 2-40
	Added values for minimum pulse width and removed the FRMAX row from Table 2-88 through Table 2-98 in the "Global Tree Timing Characteristics" section. Use the software to determine the FRMAX for the device you are using (SAR 36953).	2-64 to 2-69
	Table 2-99 • IGLOO nano CCC/PLL Specification and Table 2-100 • IGLOO nano CCC/PLL Specification were updated. A note was added indicating that when the CCC/PLL core is generated by Mircosemi core generator software, not all delay values of the specified delay increments are available (SAR 34817).	2-70 and 2-71
	The port names in the SRAM "Timing Waveforms", SRAM "Timing Characteristics" tables, Figure 2-36 • FIFO Reset, and the FIFO "Timing Characteristics" tables were revised to ensure consistency with the software names (SAR 35754). Reference was made to a new application note, <i>Simultaneous Read-Write Operations in Dual-Port SRAM for Flash-Based cSoCs and FPGAs</i> , which covers these cases in detail (SAR 34865).	2-74, 2-77, 2-85
The "Pin Descriptions" chapter has been added (SAR 34770).	3-1	
Package names used in the "Package Pin Assignments" section were revised to match standards given in <i>Package Mechanical Drawings</i> (SAR 34770).	4-1	
Revision 11 (Jul 2010)	The status of the AGLN060 device has changed from Advance to Production.	III
	The values for PAC1, PAC2, PAC3, and PAC4 were updated in Table 2-15 • Different Components Contributing to Dynamic Power Consumption in IGLOO nano Devices for 1.5 V core supply voltage (SAR 26404).	2-10
	The values for PAC1, PAC2, PAC3, and PAC4 were updated in Table 2-17 • Different Components Contributing to Dynamic Power Consumption in IGLOO nano Devices for 1.2 V core supply voltage (SAR 26404).	2-11
July 2010	The versioning system for datasheets has been changed. Datasheets are assigned a revision number that increments each time the datasheet is revised. The "IGLOO nano Device Status" table on page III indicates the status for each device in the device family.	N/A

Revision	Changes	Page
Revision 10 (Apr 2010)	References to differential inputs were removed from the datasheet, since IGLOO nano devices do not support differential inputs (SAR 21449).	N/A
	A parenthetical note, "hold previous I/O state in Flash*Freeze mode," was added to each occurrence of bus hold in the datasheet (SAR 24079).	N/A
	The "In-System Programming (ISP) and Security" section was revised to add 1.2 V programming.	I
	The note connected with the "IGLOO nano Ordering Information" table was revised to clarify features not available for Z feature grade devices.	IV
	The "IGLOO nano Device Status" table is new.	III
	The definition of C in the "Temperature Grade Offerings" table was changed to "extended commercial temperature range".	V
	1.2 V wide range was added to the list of voltage ranges in the "I/Os with Advanced I/O Standards" section.	1-8
	A note was added to Table 2-2 • Recommended Operating Conditions ¹ regarding switching from 1.2 V to 1.5 V core voltage for in-system programming. The VJTAG voltage was changed from "1.425 to 3.6" to "1.4 to 3.6" (SAR 24052). The note regarding voltage for programming V2 and V5 devices was revised (SAR 25213). The maximum value for VPUMP programming voltage (operation mode) was changed from 3.45 V to 3.6 V (SAR 25220).	2-2
	Table 2-6 • Temperature and Voltage Derating Factors for Timing Delays (normalized to T _J = 70°C, VCC = 1.425 V) and Table 2-7 • Temperature and Voltage Derating Factors for Timing Delays (normalized to T _J = 70°C, VCC = 1.14 V) were updated. Table 2-8 • Power Supply State per Mode is new.	2-6, 2-7
	The tables in the "Quiescent Supply Current" section were updated (SAR 24882 and SAR 24112).	2-7
	VJTAG was removed from Table 2-10 • Quiescent Supply Current (IDD) Characteristics, IGLOO nano Sleep Mode* (SARs 24112, 24882, and 79503).	2-8
The note stating what was included in I _{DD} was removed from Table 2-11 • Quiescent Supply Current (IDD) Characteristics, IGLOO nano Shutdown Mode. The note, "per VCCI or VJTAG bank" was removed from Table 2-12 • Quiescent Supply Current (IDD), No IGLOO nano Flash*Freeze Mode ¹ . The note giving I _{DD} was changed to "I _{DD} = N _{BANKS} * I _{CCI} + I _{CCA} ."	2-8	
The values in Table 2-13 • Summary of I/O Input Buffer Power (per pin) – Default I/O Software Settings and Table 2-14 • Summary of I/O Output Buffer Power (per pin) – Default I/O Software Settings ¹ were updated. Wide range support information was added.	2-9	

Revision	Changes	Page
Revision 10 (continued)	<p>The following tables were updated with current available information. The equivalent software default drive strength option was added.</p> <p>Table 2-21 • Summary of Maximum and Minimum DC Input and Output Levels</p> <p>Table 2-25 • Summary of I/O Timing Characteristics—Software Default Settings</p> <p>Table 2-26 • Summary of I/O Timing Characteristics—Software Default Settings</p> <p>Table 2-28 • I/O Output Buffer Maximum Resistances ¹</p> <p>Table 2-29 • I/O Weak Pull-Up/Pull-Down Resistances</p> <p>Table 2-30 • I/O Short Currents IOSH/IOSL</p> <p>Timing tables in the "Single-Ended I/O Characteristics" section, including new tables for 3.3 V and 1.2 V LVCMOS wide range.</p> <p>Table 2-40 • Minimum and Maximum DC Input and Output Levels for LVCMOS 3.3 V Wide Range</p> <p>Table 2-63 • Minimum and Maximum DC Input and Output Levels</p> <p>Table 2-67 • Minimum and Maximum DC Input and Output Levels (new)</p>	2-19 through 2-40
	The formulas in the notes to Table 2-29 • I/O Weak Pull-Up/Pull-Down Resistances were revised (SAR 21348).	2-24
	The text introducing Table 2-31 • Duration of Short Circuit Event before Failure was revised to state six months at 100° instead of three months at 110° for reliability concerns. The row for 110° was removed from the table.	2-25
	The following sentence was deleted from the "2.5 V LVCMOS" section (SAR 24916): "It uses a 5-V tolerant input buffer and push-pull output buffer."	2-32
	The $F_{DDRIMAX}$ and F_{DDOMAX} values were added to tables in the "DDR Module Specifications" section (SAR 23919). A note was added stating that DDR is not supported for AGLN010, AGLN015, and AGLN020.	2-51
	Tables in the "Global Tree Timing Characteristics" section were updated with new information available.	2-64
	Table 2-99 • IGLOO nano CCC/PLL Specification and Table 2-100 • IGLOO nano CCC/PLL Specification were revised (SAR 79390).	2-70, 2-71
	Tables in the SRAM "Timing Characteristics" section and FIFO "Timing Characteristics" section were updated with new information available.	2-77, 2-85
	Table 3-3 • TRST and TCK Pull-Down Recommendations is new.	3-4
	A note was added to the "CS81" pin tables for AGLN060, AGLN060Z, AGLN125, AGLN125Z, AGLN250, and AGLN250Z indicating that pins F1 and F2 must be grounded (SAR 25007).	4-6, through 4-13
	A note was added to the "CS81" and "VQ100" pin tables for AGLN060 and AGLN060Z stating that bus hold is not available for pin H7 or pin 45 (SAR 24079).	4-6, 4-14
	The AGLN250 function for pin C8 in the "CS81" table was revised (SAR 22134).	4-8

Revision / Version	Changes	Page
Revision 9 (Mar2010) Product Brief Advance v0.9 Packaging Advance v0.8	All product tables and pin tables were updated to show clearly that AGLN030 is available only in the Z feature grade at this time. The nano-Z feature grade devices are designated with a Z at the end of the part number.	N/A
Revision 8 (Jan 2009) Product Brief Advance v0.8 Packaging Advance v0.7	The " Reprogrammable Flash Technology " section was revised to add "250 MHz (1.5 V systems) and 160 MHz (1.2 V systems) System Performance".	I
	The note for AGLN030 in the " IGLOO nano Devices " table and " I/Os Per Package " table was revised to remove the statement regarding package compatibility with lower density nano devices.	II, II
	The " I/Os with Advanced I/O Standards " section was revised to add definitions for hot-swap and cold-sparing.	1-8
	The " UC81 ", " CS81 ", " QN48 ", and " QN68 " pin tables for AGLN030 are new.	4-3, 4-4, 4-9, 4-11
	The " CS81 " pin table for AGLN060 is new.	4-6
	The " UC81 " and " VQ100 " pin tables for AGLN060Z are new.	4-3, 4-13
	The " UC81 " and " VQ100 " pin tables for AGLN125Z are new.	4-3, 4-13
Revision 7 (Apr 2009) Product Brief Advance v0.7 DC and Switching Characteristics Advance v0.3	The -F speed grade is no longer offered for IGLOO nano devices and was removed from the datasheet.	N/A
Revision 6 (Mar 2009) Packaging Advance v0.6	The " VQ100 " pin table for AGLN030 is new.	"VQ100"
Revision 5 (Feb 2009) Packaging Advance v0.5	The "100-Pin QFN" section was removed.	N/A
Revision 4 (Feb 2009) Product Brief Advance v0.6	The QN100 package was removed for all devices.	N/A
	" IGLOO nano Devices " table was updated to change the maximum user I/Os for AGLN030 from 81 to 77.	II
	The " Device Marking " section is new.	V
Revision 3 (Feb 2009) Product Brief Advance v0.5 Packaging Advance v0.4	The following table note was removed from " IGLOO nano Devices " table: "Six chip (main) and three quadrant global networks are available for AGLN060 and above."	II
	The CS81 package was added for AGLN250 in the GLOO nano Products Available in the Z Feature Grade table.	N/A
	The " UC81 " and " CS81 " pin tables for AGLN020 are new.	4-3, 4-5
	The " CS81 " pin table for AGLN250 is new.	4-8

Revision / Version	Changes	Page
Revision 2 (Dec 2008) Product Brief Advance v0.4 Packaging Advance v0.3	The second table note in "IGLOO nano Devices" table was revised to state, "AGLN060, AGLN125, and AGLN250 in the CS81 package do not support PLLs. AGLN030 and smaller devices do not support this feature."	II
	The I/Os per package for CS81 were revised to 60 for AGLN060, AGLN125, and AGLN250 in the "I/Os Per Package" table.	II
	The "UC36" pin table is new.	4-2
Revision 1 (Nov 2008) Product Brief Advance v0.3	The "Advanced I/Os" section was updated to include wide power supply voltage support for 1.14 V to 1.575 V.	I
	The AGLN030 device was added to product tables and replaces AGL030 entries that were formerly in the tables.	N/A
	The "I/Os Per Package" table was updated for the CS81 package to change the number of I/Os for AGLN060, AGLN125, and AGLN250 from 66 to 64.	II
	The "Wide Range I/O Support" section is new.	1-8
	The table notes and references were revised in Table 2-2 • Recommended Operating Conditions ¹ . VMV was included with VCCI and a table note was added stating, "VMV pins must be connected to the corresponding VCCI pins. See <i>Pin Descriptions</i> for further information." Please review carefully.	2-2
	VJTAG was added to the list in the table note for Table 2-9 • Quiescent Supply Current (IDD) Characteristics, IGLOO nano Flash*Freeze Mode* . Values were added for AGLN010, AGLN015, and AGLN030 for 1.5 V.	2-7
	VCCI was removed from the list in the table note for Table 2-10 • Quiescent Supply Current (IDD) Characteristics, IGLOO nano Sleep Mode* .	2-8
	Values for I _{CCA} current were updated for AGLN010, AGLN015, and AGLN030 in Table 2-12 • Quiescent Supply Current (IDD), No IGLOO nano Flash*Freeze Mode ¹ .	2-8
	Values for PAC1 and PAC2 were added to Table 2-15 • Different Components Contributing to Dynamic Power Consumption in IGLOO nano Devices and Table 2-17 • Different Components Contributing to Dynamic Power Consumption in IGLOO nano Devices .	2-10, 2-11
	Table notes regarding wide range support were added to Table 2-21 • Summary of Maximum and Minimum DC Input and Output Levels .	2-19
	1.2 V LVCMOS wide range values were added to Table 2-22 • Summary of Maximum and Minimum DC Input Levels and Table 2-23 • Summary of AC Measuring Points .	2-19, 2-20
	The following table note was added to Table 2-25 • Summary of I/O Timing Characteristics—Software Default Settings and Table 2-26 • Summary of I/O Timing Characteristics—Software Default Settings : "All LVCMOS 3.3 V software macros support LVCMOS 3.3 V wide range, as specified in the JESD8-B specification."	2-21
3.3 V LVCMOS Wide Range and 1.2 V Wide Range were added to Table 2-28 • I/O Output Buffer Maximum Resistances ¹ and Table 2-30 • I/O Short Currents IOSH/IOSL .	2-23, 2-24	

Revision / Version	Changes	Page
Revision 1 (cont'd)	The "QN48" pin diagram was revised.	4-10
Packaging Advance v0.2	Note 2 for the "QN48", "QN68", and "100-Pin QFN" pin diagrams was changed to "The die attach paddle of the package is tied to ground (GND)."	4-10, 4-11
	The "VQ100" pin diagram was revised to move the pin IDs to the upper left corner instead of the upper right corner.	4-13
Revision 0 (Oct 2008) Product Brief Advance v0.2	The following tables and sections were updated to add the UC81 and CS81 packages for AGL030: "IGLOO nano Devices" "I/Os Per Package" IGLOO nano Products Available in the Z Feature Grade "Temperature Grade Offerings"	1-V
	The "I/Os Per Package" table was updated to add the following information to table note 4: "For nano devices, the VQ100 package is offered in both leaded and RoHS-compliant versions. All other packages are RoHS-compliant only."	II
	The IGLOO nano Products Available in the Z Feature Grade section was updated to remove QN100 for AGLN250.	N/A
	The device architecture figures, Figure 1-3 • IGLOO Device Architecture Overview with Two I/O Banks (AGLN060, AGLN125) through Figure 1-4 • IGLOO Device Architecture Overview with Four I/O Banks (AGLN250) , were revised. Figure 1-1 • IGLOO Device Architecture Overview with Two I/O Banks and No RAM (AGLN010 and AGLN030) is new.	1-4 through 1-5
	The "PLL and CCC" section was revised to include information about CCC-GLs in AGLN020 and smaller devices.	1-7
	The "I/Os with Advanced I/O Standards" section was revised to add information about IGLOO nano devices supporting double-data-rate applications.	1-8

Datasheet Categories

Categories

In order to provide the latest information to designers, some datasheet parameters are published before data has been fully characterized from silicon devices. The data provided for a given device, as highlighted in the "IGLOO nano Device Status" table on page III, is designated as either "Product Brief," "Advance," "Preliminary," or "Production." The definitions of these categories are as follows:

Product Brief

The product brief is a summarized version of a datasheet (advance or production) and contains general product information. This document gives an overview of specific device and family information.

Advance

This version contains initial estimated information based on simulation, other products, devices, or speed grades. This information can be used as estimates, but not for production. This label only applies to the DC and Switching Characteristics chapter of the datasheet and will only be used when the data has not been fully characterized.

Preliminary

The datasheet contains information based on simulation and/or initial characterization. The information is believed to be correct, but changes are possible.

Unmarked (production)

This version contains information that is considered to be final.

Export Administration Regulations (EAR)

The products described in this document are subject to the Export Administration Regulations (EAR). They could require an approved export license prior to export from the United States. An export includes release of product or disclosure of technology to a foreign national inside or outside the United States.

Safety Critical, Life Support, and High-Reliability Applications Policy

The Microsemi products described in this advance status document may not have completed Microsemi's qualification process. Microsemi may amend or enhance products during the product introduction and qualification process, resulting in changes in device functionality or performance. It is the responsibility of each customer to ensure the fitness of any Microsemi product (but especially a new product) for a particular purpose, including appropriateness for safety-critical, life-support, and other high-reliability applications. Consult Microsemi's Terms and Conditions for specific liability exclusions relating to life-support applications. A reliability report covering all of the Microsemi SoC Products Group's products is at http://www.microsemi.com/socdocuments/ORT_Report.pdf. Microsemi also offers a variety of enhanced qualification and lot acceptance screening procedures. Contact your local Microsemi sales office for additional reliability information.



Microsemi Corporate Headquarters

One Enterprise, Aliso Viejo,
CA 92656 USA

Within the USA: +1 (800) 713-4113
Outside the USA: +1 (949) 380-6100

Sales: +1 (949) 380-6136
Fax: +1 (949) 215-4996

E-mail: sales.support@microsemi.com
www.microsemi.com

©2019 Microsemi, a wholly owned subsidiary of Microchip Technology Inc. All rights reserved. Microsemi and the Microsemi logo are registered trademarks of Microsemi Corporation. All other trademarks and service marks are the property of their respective owners.

Microsemi makes no warranty, representation, or guarantee regarding the information contained herein or the suitability of its products and services for any particular purpose, nor does Microsemi assume any liability whatsoever arising out of the application or use of any product or circuit. The products sold hereunder and any other products sold by Microsemi have been subject to limited testing and should not be used in conjunction with mission-critical equipment or applications. Any performance specifications are believed to be reliable but are not verified, and Buyer must conduct and complete all performance and other testing of the products, alone and together with, or installed in, any end-products. Buyer shall not rely on any data and performance specifications or parameters provided by Microsemi. It is the Buyer's responsibility to independently determine suitability of any products and to test and verify the same. The information provided by Microsemi hereunder is provided "as is, where is" and with all faults, and the entire risk associated with such information is entirely with the Buyer. Microsemi does not grant, explicitly or implicitly, to any party any patent rights, licenses, or any other IP rights, whether with regard to such information itself or anything described by such information. Information provided in this document is proprietary to Microsemi, and Microsemi reserves the right to make any changes to the information in this document or to any products and services at any time without notice.

About Microsemi

Microsemi, a wholly owned subsidiary of Microchip Technology Inc. (Nasdaq: MCHP), offers a comprehensive portfolio of semiconductor and system solutions for aerospace & defense, communications, data center and industrial markets. Products include high-performance and radiation-hardened analog mixed-signal integrated circuits, FPGAs, SoCs and ASICs; power management products; timing and synchronization devices and precise time solutions, setting the world's standard for time; voice processing devices; RF solutions; discrete components; enterprise storage and communication solutions, security technologies and scalable anti-tamper products; Ethernet solutions; Power-over-Ethernet ICs and midspans; as well as custom design capabilities and services. Learn more at www.microsemi.com.