

Hermetically Sealed Analog Isolation Amplifier

Data Sheet

Description

The HCPL-7850, HCPL-7851, and ACPL-785E are isolation amplifiers that provide accurate, electrically isolated and amplified representations of voltage and current. When used with a shunt resistor to monitor the motor phase current in a high-speed motor drive, the device offers superior reliability compared with the traditional solutions such as current transformers and Hall-effect sensors. These devices consist of a sigma-delta analog-to-digital converter optically coupled to a digital-to-analog converter in a hermetically sealed package. The products are capable of operation and storage over the full military temperature range and can be purchased as a commercial product (HCPL-7850), with full MIL-PRF-38534 Class H testing (HCPL-7851), with MIL-PRF-38534 Class E testing (ACPL-785E) (Class K with exceptions) or from the DLA Standard Microcircuit Drawing (SMD) 5962-97557. Details of the Class E program exceptions are listed here:

1. Nondestructive Bond Pull, Test method 2023 of MIL-STD-883 in screening is not required.
2. Particle Impact Noise Detection (PIND), Test method 2020 of MIL-STD-883 in device screening and group C testing is not required.
3. Die Shear Strength, Test method 2019 of MIL-STD-883 in group B testing is not required.
4. Internal Water Vapor Content, Test method 1018 of MIL-STD-883 in group C is not required.
5. Scanning Electron Microscope (SEM) inspection, Test method 2018 of MIL-STD-883 in element evaluation is not required.

1. See [Selection Guide – Lead Configuration Options](#) for available extensions.

Features

- Performance guaranteed over full military temperature range: -55°C to $+125^{\circ}\text{C}$
- Manufactured and tested on a MIL-PRF-38534 certified line
- Hermetically sealed packages
- Dual marked with device part number and DLA Standard Microcircuit Drawing (SMD)
- QML-38534, Class H and Class E
- HCPL-7840 function compatibility
- High common-mode rejection (CMR): $8\text{ kV}/\mu\text{s}$ at $\text{VCM} = 1000\text{V}$
- 5% gain tolerance
- 0.1% nonlinearity
- Low offset voltage and offset temperature coefficient
- 100 kHz bandwidth

Applications

- Industrial, military, and space systems
- High reliability systems
- Harsh industrial environments
- Transportation, medical, and life critical systems
- General-purpose analog signal isolation

CAUTION

It is advised that normal static precautions be taken in handling and assembly of this component to prevent damage and/or degradation which may be induced by ESD.

Schematic Diagram

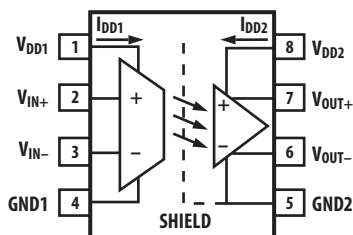

NOTE A 0.1- μ F bypass capacitor must be connected between pins 1 and 4 and between pins 5 and 8.

Superior performance in design-critical specifications, such as common-mode rejection, offset voltage, nonlinearity, and operating temperature, makes the HCPL-7850, HCPL-7851 and ACPL-785E excellent choices for designing reliable products such as motor controllers and inverters.

With common-mode rejection of 8 kV/ μ s, these devices are suitable for noisy electrical environments such as those generated by the high switching rates of power IGBTs.

Low offset voltage together with a low offset voltage temperature coefficient permits accurate use of auto-calibration techniques.

Gain tolerance of 5% with 0.1% nonlinearity further provide the performance necessary for accurate feedback and control.

Selection Guide – Lead Configuration Options

Part Number and Options		
Commercial	HCPL-7850	
MIL-PRF-38534, Class H	HCPL-7851	
MIL-PRF-38534, Class E		ACPL-785E
Standard Lead Finish	Gold Plate ^a	Gold Plate ^a
Solder Dipped ^b	Option #200	Option -200
Butt Cut/Gold Plate ^a	Option #100	Option -100
Gull Wing/Soldered ^b	Option #300	Option -300
SMD Part Number		
Prescript for all below	5962-	5962-
Gold Plate ^a	9755701HPC	9755701EPC
Solder Dipped ^b	9755701HPA	9755701EPA
Butt Cut/Gold Plate ^a	9755701HYC	9755701EYC
Butt Cut/Soldered ^b	9755701HYA	9755701EYA
Gull Wing/Soldered ^b	9755701HXA	9755701EXA

a. Gold Plate lead finish: Maximum gold thickness of leads is <100 micro inches. Typical is 60 to 90 micro inches.

b. Solder lead finish: Sn63/Pb37.

Device Marking

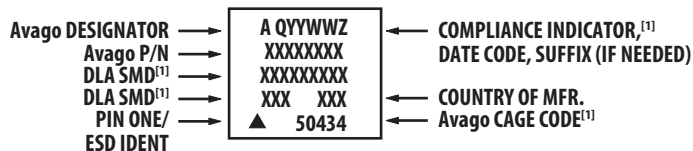

[1] QML PARTS ONLY

Outline Drawing

8-Pin DIP Through Hole

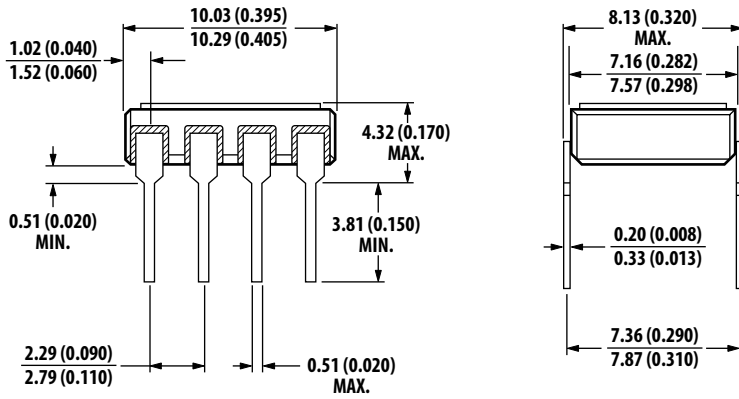

NOTE: DIMENSIONS IN MILLIMETERS (INCHES).

Hermetic Optocoupler Options

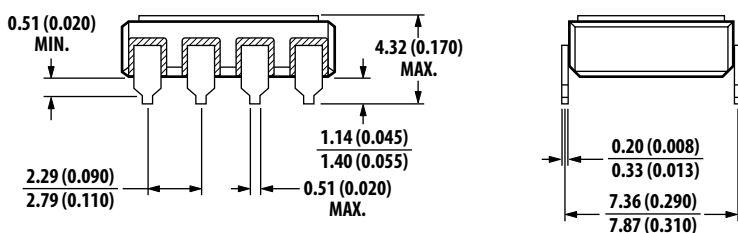
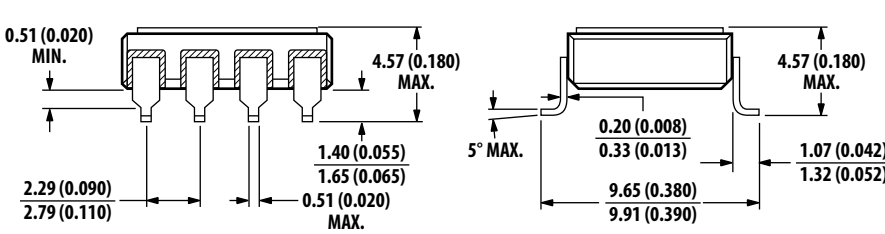
Option	Description
100	Surface-mountable hermetic optocoupler with leads trimmed for butt joint assembly. This option is available on Commercial, Class H and Class E product in 8-pin DIP.  <p>Technical drawing of an 8-pin DIP package with butt joint assembly. The drawing includes a top view and a side view. Dimensions are provided in millimeters (mm) and inches (in).</p> <p>Top View Dimensions:</p> <ul style="list-style-type: none"> Lead width: 0.51 (0.020) mm MIN. Lead spacing: 1.52 (0.060) mm Package width: 10.03 (0.395) mm Package length: 10.29 (0.405) mm Lead height: 0.51 (0.020) mm MIN. Lead length: 2.29 (0.090) mm Lead length: 2.79 (0.110) mm Lead length: 0.51 (0.020) mm MAX. Lead length: 1.40 (0.055) mm Lead length: 1.14 (0.045) mm Lead length: 4.32 (0.170) mm MAX. <p>Side View Dimensions:</p> <ul style="list-style-type: none"> Package height: 8.13 (0.320) mm MAX. Package height: 7.16 (0.282) mm Package height: 7.57 (0.298) mm Lead width: 0.20 (0.008) mm Lead width: 0.33 (0.013) mm Lead length: 7.36 (0.290) mm Lead length: 7.87 (0.310) mm <p>NOTE: DIMENSIONS IN MILLIMETERS (INCHES).</p>
200	Lead finish is solder dipped rather than gold plated. This option is available on Commercial, Class H and Class E product in 8-pin DIP. DLA Drawing (SMD) part numbers contain provisions for lead finish.
300	Surface-mountable hermetic optocoupler with leads cut and bent for gull wing assembly. This option is available on Commercial, Class H and Class E product in 8-pin DIP. This option has solder-dipped leads.  <p>Technical drawing of an 8-pin DIP package with gull wing assembly. The drawing includes a top view and a side view. Dimensions are provided in millimeters (mm) and inches (in).</p> <p>Top View Dimensions:</p> <ul style="list-style-type: none"> Lead width: 0.51 (0.020) mm MIN. Lead spacing: 1.52 (0.060) mm Package width: 10.03 (0.395) mm Package length: 10.29 (0.405) mm Lead height: 0.51 (0.020) mm MIN. Lead length: 2.29 (0.090) mm Lead length: 2.79 (0.110) mm Lead length: 0.51 (0.020) mm MAX. Lead length: 1.65 (0.065) mm Lead length: 1.40 (0.055) mm Lead length: 4.57 (0.180) mm MAX. <p>Side View Dimensions:</p> <ul style="list-style-type: none"> Package height: 8.13 (0.320) mm MAX. Package height: 7.16 (0.282) mm Package height: 7.57 (0.298) mm Lead width: 0.20 (0.008) mm Lead width: 0.33 (0.013) mm Lead length: 9.65 (0.380) mm Lead length: 9.91 (0.390) mm Lead angle: 5° MAX. Lead length: 1.07 (0.042) mm Lead length: 1.32 (0.052) mm <p>NOTE: DIMENSIONS IN MILLIMETERS (INCHES).</p>

Absolute Maximum Ratings

Parameter	Symbol	Min	Max	Unit	Notes
Storage Temperature	T_S	-65	+150	°C	
Operating Temperature	T_A	-55	+125	°C	
Supply Voltages	V_{DD1}, V_{DD2}	0.0	+5.5	V	
Steady-State Input Voltage	V_{IN+}, V_{IN-}	-2.0	$V_{DD1} + 0.5$	V	a
2 Second Transient Input Voltage		-6.0	$V_{DD1} + 0.5$	V	a
Output Voltages	V_{OUT+}, V_{OUT-}	-0.5	$V_{DD2} + 0.5$	V	
Lead Solder Temperature		—	260 for 10 sec	°C	

a. If V_{IN-} is brought above $V_{DD1} - 2V$ with respect to GND1 an internal test mode may be activated. This test mode is not intended for customer use.

ESD Classification

(MIL-STD-883, Method 3015)	
HCPL-7850, HCPL-7851, and ACPL-785E	▲, Class 1

Recommended Operating Conditions

Parameter	Symbol	Min	Max	Unit
Supply Voltages	V_{DD1}, V_{DD2}	4.5	5.5	V
Input Voltage ^a	V_{IN+}, V_{IN-}	-200	+200	mV

a. If V_{IN-} is brought above $V_{DD1} - 2V$ with respect to GND1 an internal test mode may be activated. This test mode is not intended for customer use.

DC Electrical Specifications

Over recommended operating conditions ($T_A = -55^\circ\text{C}$ to $+125^\circ\text{C}$, $V_{IN+} = 0\text{V}$, $V_{IN-} = 0\text{V}$, $V_{DD1} = 5\text{V}$ and $V_{DD2} = 5\text{V}$, unless otherwise specified).

Parameter	Symbol	Group A ^a Subgroups	Min	Typ ^b	Max	Unit	Test Conditions	Fig	Notes
Input Offset Voltage	V_{OS}	1, 2, 3	-1.0	0.6	5.0	mV	$4.5\text{V} \leq (V_{DD1}, V_{DD2}) \leq 5.5\text{V}$	1, 2, 3	c
Gain	G	2, 3	7.36	8.00	8.64	V/V	$-200\text{ mV} \leq V_{IN+} \leq 200\text{ mV}$, $4.5\text{V} \leq (V_{DD1}, V_{DD2}) \leq 5.5\text{V}$	5, 6, 7	
		1	7.60	8.00	8.4				
20-mV Nonlinearity	NL_{200}	2, 3	—	0.05	0.8	%	$-200\text{ mV} \leq V_{IN+} \leq 200\text{ mV}$, $4.5\text{V} \leq (V_{DD1}, V_{DD2}) \leq 5.5\text{V}$	5, 8, 9, 10, 12	d
		1	—	0.05	0.2				
10-mV Nonlinearity	NL_{100}	2, 3	—	0.01	0.2		$-100\text{ mV} \leq V_{IN+} \leq 100\text{ mV}$, $4.5\text{V} \leq (V_{DD1}, V_{DD2}) \leq 5.5\text{V}$	5, 8, 9, 11, 12	
		1	—	0.01	0.1				
Output Common-Mode Voltage	V_{OCM}	1, 2, 3	2.20	2.56	2.80	V	$-400\text{ mV} \leq V_{IN+} \leq 400\text{ mV}$, $4.5\text{V} \leq (V_{DD1}, V_{DD2}) \leq 5.5\text{V}$		
Input Supply Current	I_{DD1}	1, 2, 3	—	10.7	15.5	mA		14, 16	
Output Supply Current	I_{DD2}	1, 2, 3	—	9.4	17	mA		15, 16	
Input-Output Insulation Leakage Current	I_{I-O}	1	—	—	1.0	μA	$RH \leq 65\%$, $t = 5\text{ sec.}$ $V_{I-O} = 1500\text{ Vdc}$, $T_A = 25^\circ\text{C}$		e
Maximum Input Voltage Before Output Clipping	$ V_{IN+} _{MAX}$		—	320	—	mV		4, 12	
Average Input Bias Current	I_{IN}		—	-0.57	—	μA		13	f
Average Input Resistance	R_{IN}		—	480	—	k Ω			
Input DC Common-Mode Rejection Ratio	$CMRR_{IN}$		—	69	—	dB			g
Output Resistance	R_O		—	1	—	Ω			
Output Low Voltage	V_{OL}		—	1.28	—	V	$V_{IN+} = 400\text{ mV}$	4	h
Output High Voltage	V_{OH}		—	3.84	—	V	$V_{IN+} = -400\text{ mV}$		
Output Short-Circuit Current	$ I_{OSC} $		—	11	—	mA	$V_{OUT} = 0\text{V}$ or V_{DD2}		i
Resistance (Input-Output)	R_{I-O}		—	10^{12}	—	Ω	$V_{I-O} = 500\text{ Vdc}$		e
Capacitance (Input-Output)	C_{I-O}		—	2.7	—	pF	$f = 1\text{ MHz}$, $V_{I-O} = 0\text{ Vdc}$		

- Commercial parts receive 100% testing at 25°C (Subgroups 1 and 9). SMD, Class H and Class E receive 100% testing at 25, 125, and -55°C (Subgroups 1 and 9, 2 and 10, 3 and 11, respectively).
- All typicals are at the nominal operating conditions of $V_{IN+} = 0\text{V}$, $V_{IN-} = 0\text{V}$, $T_A = 25^\circ\text{C}$, $V_{DD1} = 5\text{V}$ and $V_{DD2} = 5\text{V}$.
- Exact offset value is dependent on layout of external bypass capacitors. The offset value in the data sheet corresponds to Broadcom's recommended layout (see [Figure 26](#) and [Figure 27](#)).
- Nonlinearity is defined as half of the peak-to-peak output deviation from the best-fit gain line, expressed as a percentage of the full-scale differential output voltage.
- Device considered a two-terminal device: Pins 1, 2, 3, and 4 are shorted together, and pins 5, 6, 7, and 8 are shorted together.
- Because of the switched capacitor nature of the sigma-delta A/D converter, time averaged values are shown.
- $CMRR_{IN}$ is defined as the ratio of the gain for differential inputs applied between pins 2 and 3 to the gain for both common-mode inputs applied to both pins 2 and 3 with respect to pin 4.
- When the differential input signal exceeds approximately 320 mV, the outputs will limit at the typical values shown.
- Short-circuit current is the amount of output current generated when either output is shorted to V_{DD2} or ground. Broadcom does not recommend operations under these conditions.

AC Electrical Specifications

Over recommended operating conditions ($T_A = -55^\circ\text{C}$ to $+125^\circ\text{C}$, $V_{IN+} = 0\text{V}$, $V_{IN-} = 0\text{V}$, $V_{DD1} = 5\text{V}$ and $V_{DD2} = 5\text{V}$, unless otherwise specified).

Parameter	Symbol	Group A ^a Subgroups	Min	Typ ^b	Max	Unit	Test Conditions	Fig	Notes
Common-Mode Rejection	CMR	9	5	8	5.0	kV/ μs	$V_{CM} = 1\text{ kV}$ $4.5\text{V} \leq (V_{DD1}, V_{DD2}) \leq 5.5\text{V}$, $T_A = 25^\circ\text{C}$	17	c, d
Propagation Delay to 50%	t_{PD50}	9, 10, 11	—	3.7	7.5	μs	$V_{IN+} = 0$ to 100 mV step $4.5\text{V} \leq (V_{DD1}, V_{DD2}) \leq 5.5\text{V}$	18, 19	
Propagation Delay to 90%	t_{PD90}	9, 10, 11	—	5.7	11.0				
Rise/Fall Time (10% to 90%)	$t_{R/F}$	9, 10, 11	—	3.4	7.5				
Small-Signal Bandwidth (-3 dB)	$f_{-3\text{dB}}$	9, 10, 11	45	100	—	kHz	$4.5\text{V} \leq (V_{DD1}, V_{DD2}) \leq 5.5\text{V}$ $V_{IN+} = 200\text{ mVpk-pk}$	18, 20, 21	e
Small-Signal Bandwidth (-45°)	f_{-45°		—	31	—				
RMS Input-Referred Noise	V_N		—	0.6	—	mV _{rms}	In recommended application circuit	22, 24	f
Power Supply Rejection	PSR		—	570	—	mV _{P-P}			g

- Commercial parts receive 100% testing at 25°C (Subgroups 1 and 9). SMD, Class H and Class E receive 100% testing at 25, 125, and -55°C (Subgroups 1 and 9, 2 and 10, 3 and 11, respectively).
- All typicals are at the nominal operating conditions of $V_{IN+} = 0\text{V}$, $V_{IN-} = 0\text{V}$, $T_A = 25^\circ\text{C}$, $V_{DD1} = 5\text{V}$ and $V_{DD2} = 5\text{V}$.
- CMR (also known as IMR or Isolation Mode Rejection) specifies the minimum rate of rise of a common-mode signal applied across the isolation boundary at which small output perturbations begin to occur. These output perturbations can occur with both the rising and falling edges of the common-mode waveform and may be of either polarity. A CMR failure is defined as a perturbation exceeding 200 mV at the output of the recommended application circuit (Figure 24). See Applications for more information on CMR.
- Parameters are tested as part of device initial characterization and after design and process changes only. Parameters are guaranteed to limits specified for all lots not specifically tested.
- The $f_{-3\text{dB}}$ test is guaranteed by the T_{RISE} test.
- Output noise comes from two primary sources: chopper noise and sigma-delta quantization noise. Chopper noise results from chopper stabilization of the output op-amps. It occurs at a specific frequency (typically 500 kHz) and is not attenuated by the on-chip output filter. The on-chip filter does eliminate most, but not all, of the sigma-delta quantization noise. An external filter circuit may be easily added to the external post-amplifier to reduce the total RMS output noise. See Applications for more information.
- Data sheet value is the amplitude of the transient at the differential output of the device when a 1 V_{P-P}, 1 MHz square wave with 100 ns rise and fall times (measured at pins 1 and 8) is applied to both V_{DD1} and V_{DD2} .

Figure 1 Input Offset Voltage Test Circuit

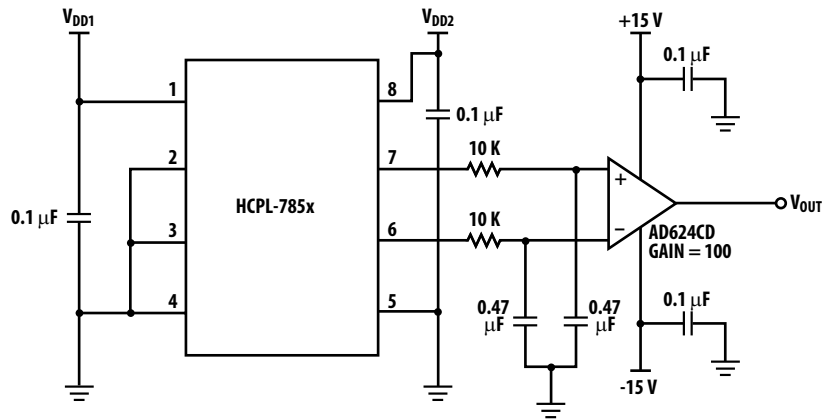

Figure 2 Gain Change vs. Temperature

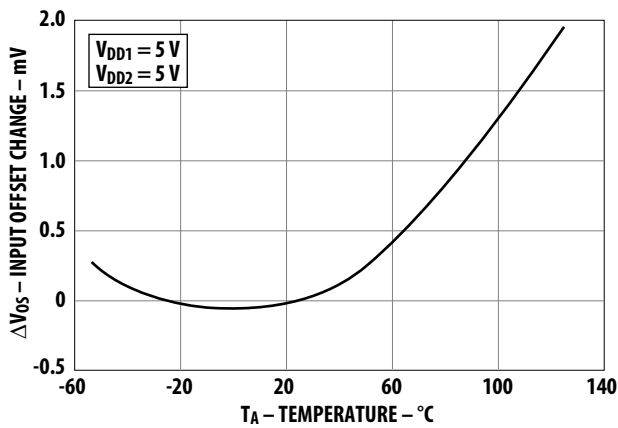

Figure 3 Input Off set Change vs. V_{DD1} and V_{DD2}

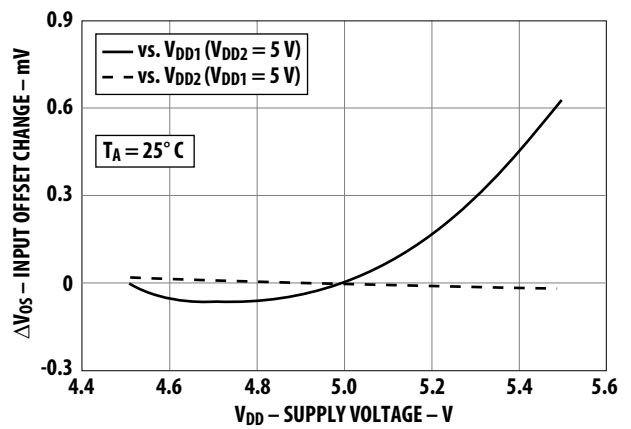

Figure 4 Output Voltages vs. Input Voltage

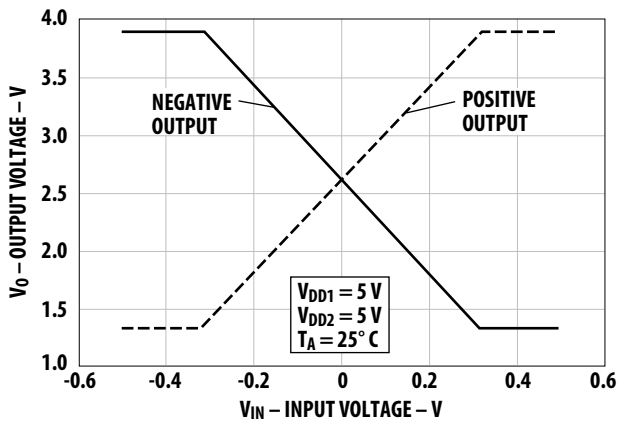

Figure 5 Gain and Nonlinearity Test Circuit

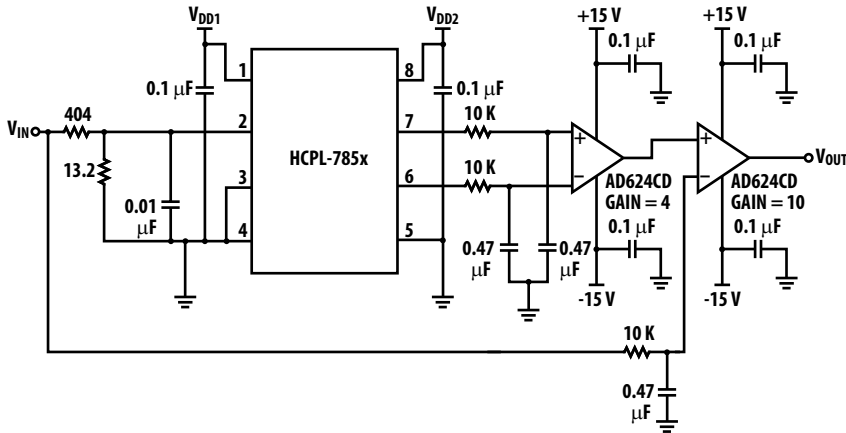

Figure 6 Gain Change vs. Temperature

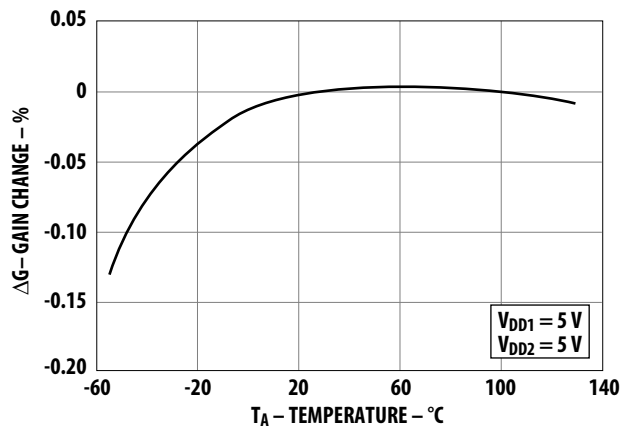

Figure 7 Gain Change vs. V_{DD1} and V_{DD2}

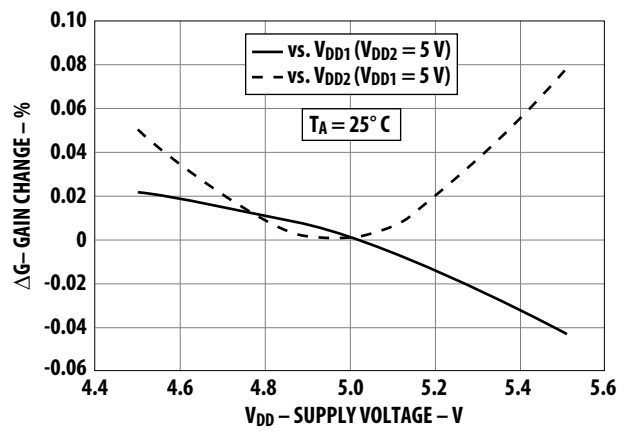

Figure 8 Nonlinearity Error Plot vs. Input Voltage

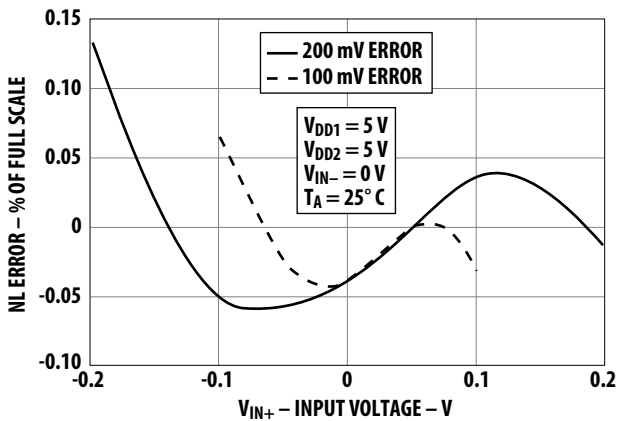

Figure 9 Nonlinearity vs. Temperature

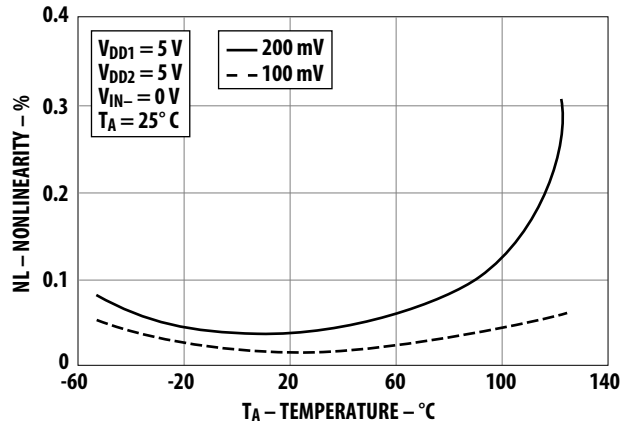

Figure 10 200-mV Nonlinearity vs. V_{DD1} and V_{DD2}

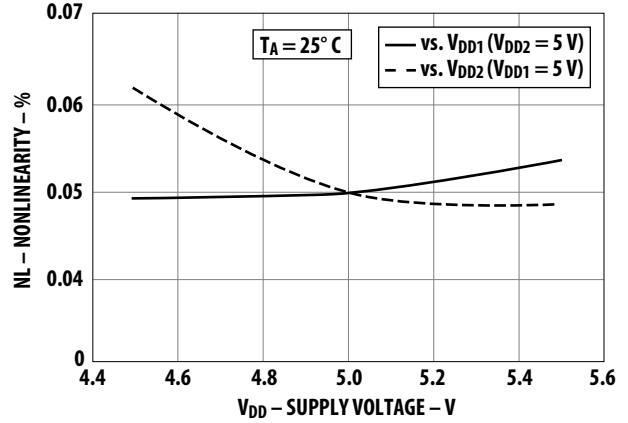

Figure 11 100-mV Nonlinearity vs. V_{DD1} and V_{DD2}

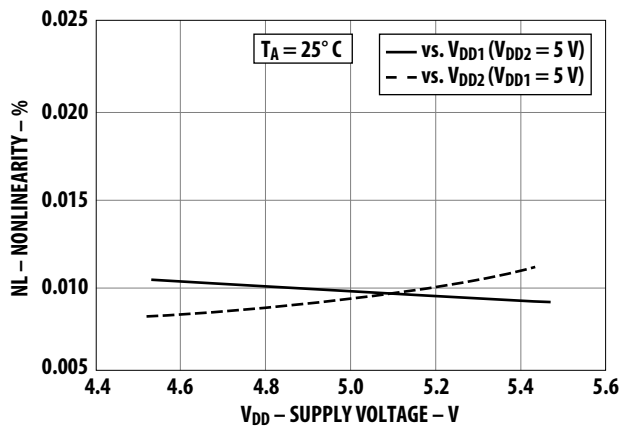

Figure 12 Nonlinearity vs. Full-Scale Input Voltage

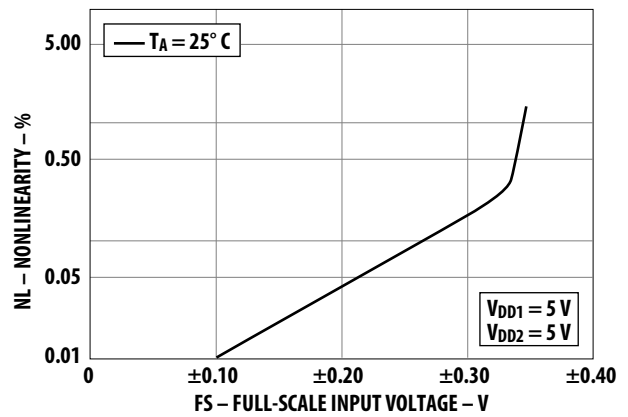

Figure 13 Input Current vs. Input Voltage

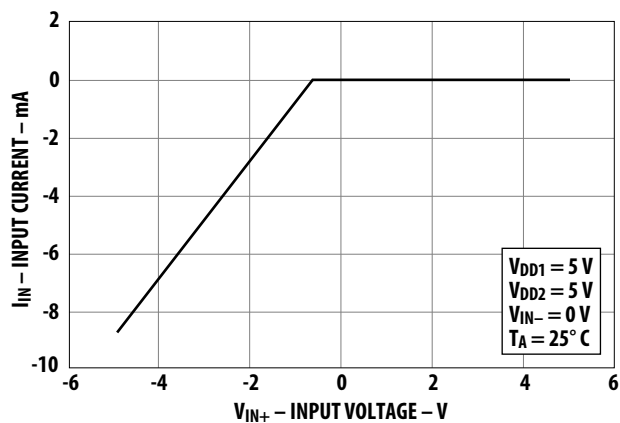

Figure 14 Input Supply Current vs. Input Voltage

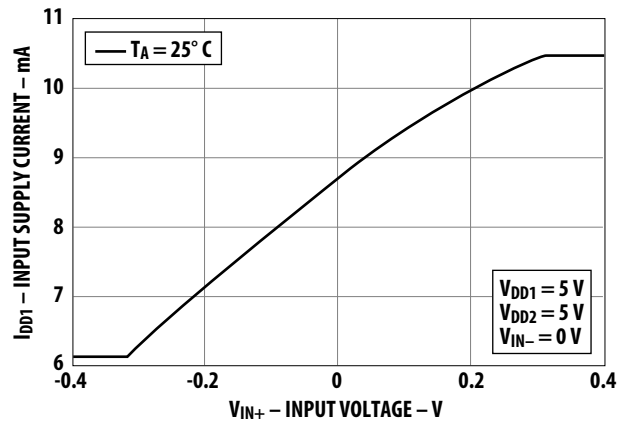

Figure 15 Output Supply Current vs. Input Voltage

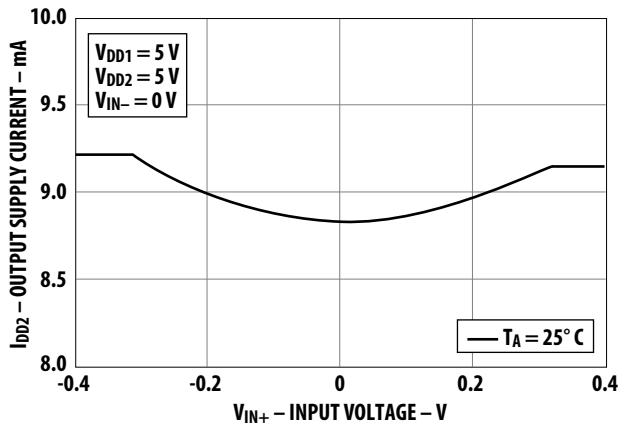

Figure 16 Input and Output Supply Current vs. Temperature

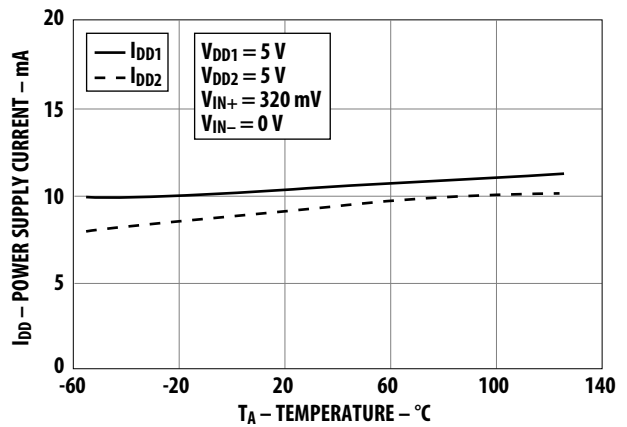

Figure 17 Common-Mode Rejection Test Circuit

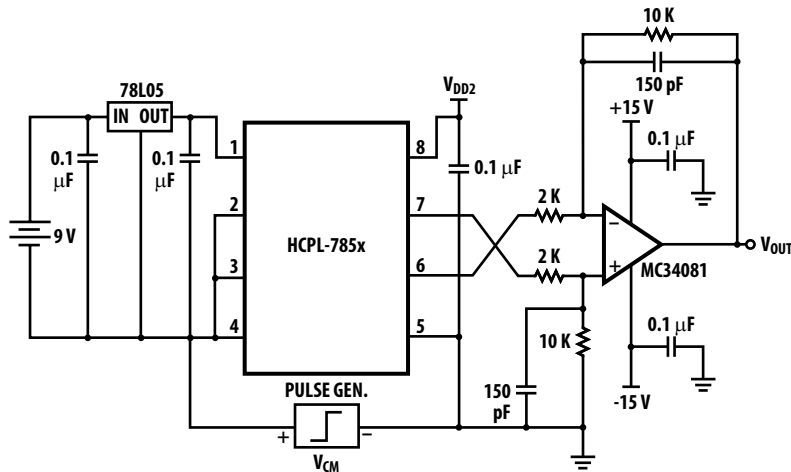
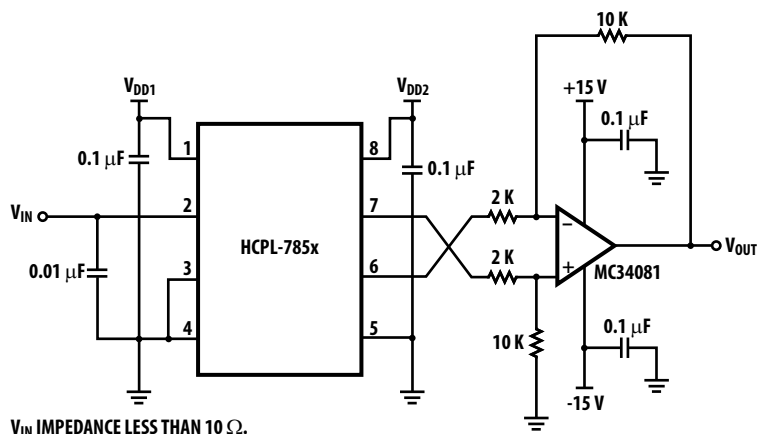

Figure 18 Propagation Delay, Rise/Fall Time and Bandwidth Test Circuit



V_{IN} IMPEDANCE LESS THAN 10 Ω .

Figure 19 Propagation Delays and Rise/Fall Time vs. Temperature

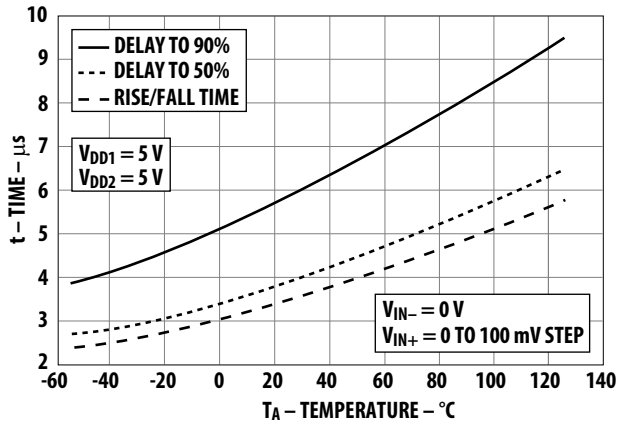

Figure 20 Amplitude Response vs. Frequency

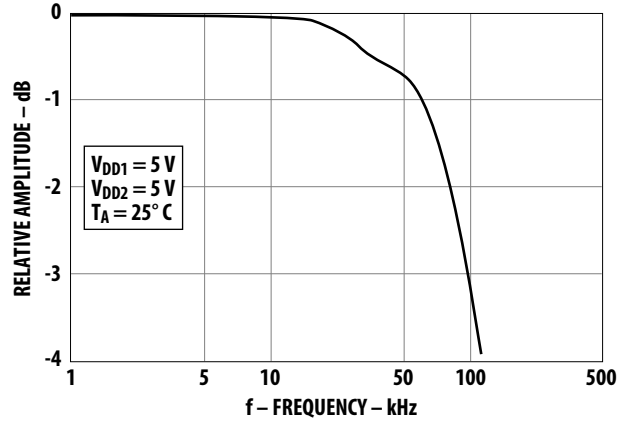

Figure 21 3-dB Bandwidth vs. Temperature

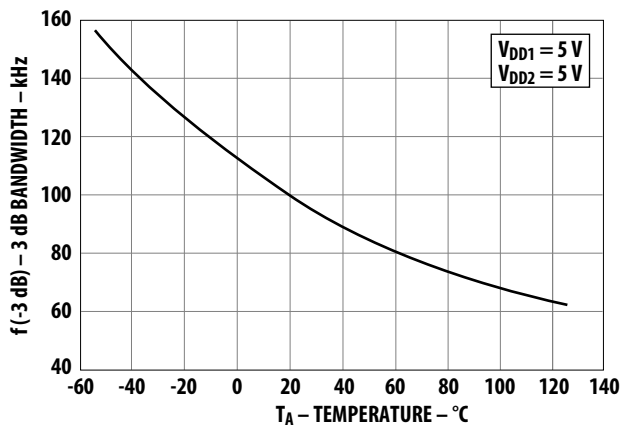

Figure 22 RMS Input-Referred Noise vs. Recommended Application Circuit Bandwidth

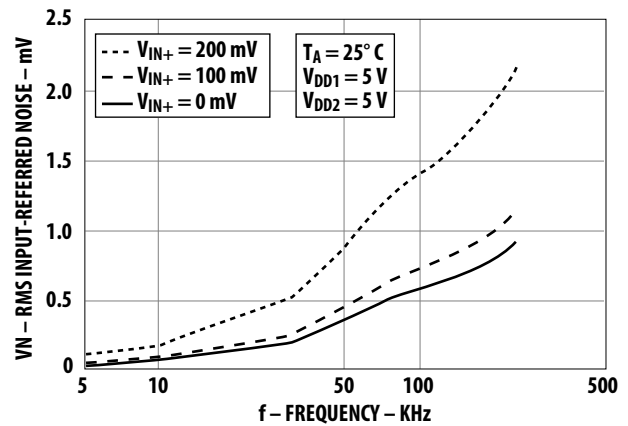

Figure 23 HCPL-785x Block Diagram

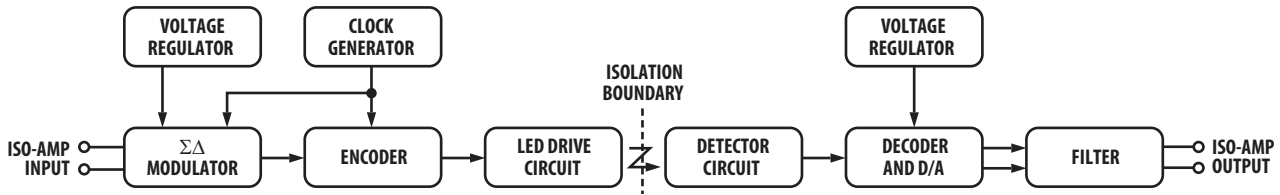
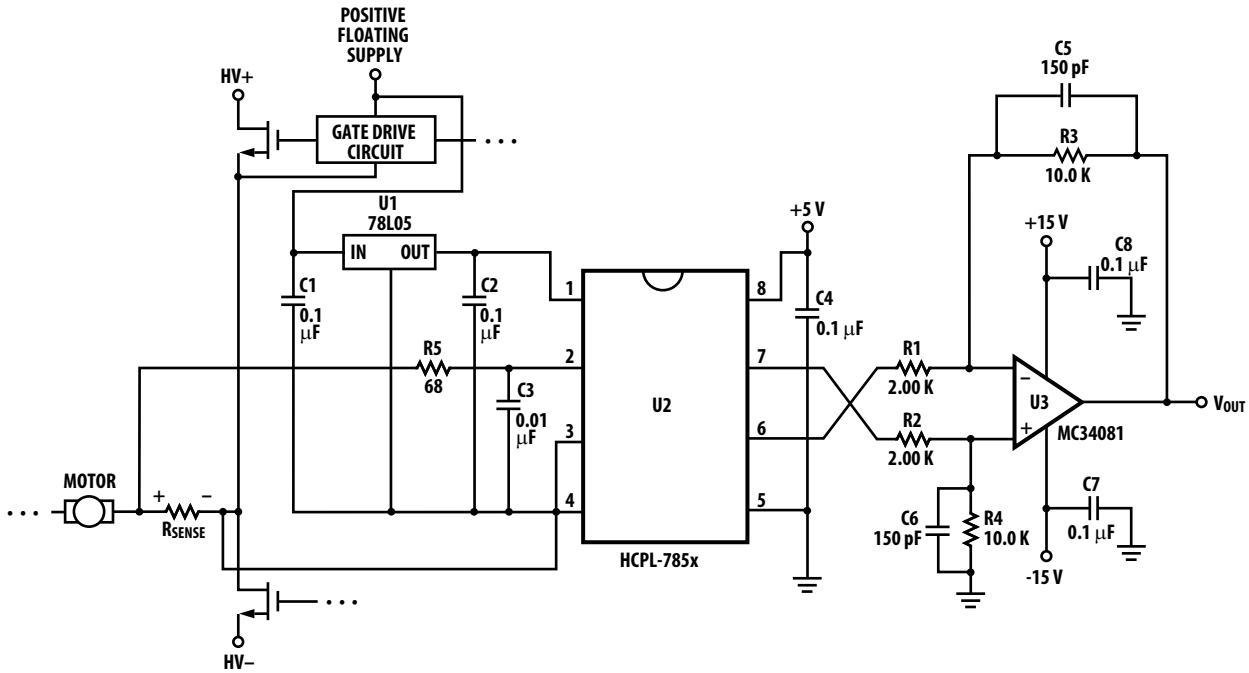

Figure 24 Recommended Application Circuit



Applications Information

Functional Description

Figure 23 shows the primary functional blocks of the HCPL-785x. In operation, the sigma-delta modulator converts the analog input signal into a high-speed serial bit stream. The time average of this bit stream is directly proportional to the input signal. This stream of digital data is encoded and optically transmitted to the detector circuit. The detected signal is decoded and converted back into an analog signal, which is filtered to obtain the final output signal.

Application Circuit

The recommended application circuit is shown in Figure 24. A floating power supply (which in many applications could be the same supply that is used to drive the high-side power transistor) is regulated to 5V using a simple three-terminal voltage regulator (U1). The voltage from the current sensing resistor, or shunt (R_{sense}), is applied to the input of the HCPL-785x through an RC anti-aliasing filter (R_5 , C_3). And finally, the differential output of the isolation amplifier is converted to a ground-referenced single-ended output voltage with a simple differential amplifier circuit (U_3 and associated components). Although the application circuit is relatively simple, a few recommendations should be followed to ensure optimal performance.

Figure 25 Single-Supply Post-Amplifier Circuit

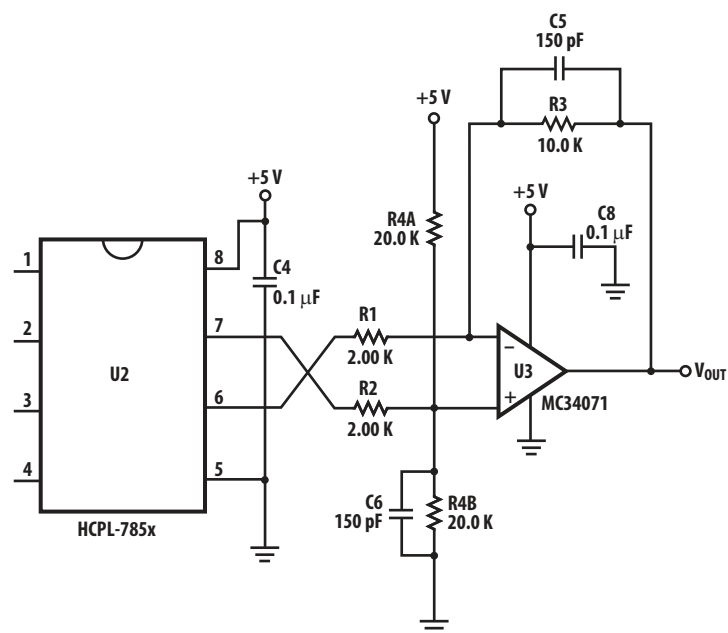

Supplies and Bypassing

As mentioned, an inexpensive three-terminal regulator can be used to reduce the gate-drive power supply voltage to 5V. To help attenuate high frequency power supply noise or ripple, a resistor or inductor can be used in series with the input of the regulator to form a low-pass filter with the regulator's input bypass capacitor.

As shown in Figure 24, a 0.1- μ F bypass capacitor (C_2 , C_4) should be located as close as possible to the input and output power supply pins of the HCPL-785x. The bypass capacitors are required because of the high-speed digital nature of the signals inside the isolation amplifier. A 0.01- μ F bypass capacitor (C_3) is also recommended at the input pin(s) due to the switched-capacitor nature of the input circuit. The input bypass capacitor should be at least 1000 pF to maintain gain accuracy of the isolation amplifier.

Inductive coupling between the input power-supply capacitor and the input circuit, including the input bypass capacitor and the input leads of the HCPL-785x, can introduce additional DC offset in the circuit. Several steps can be taken to minimize the mutual coupling between the two parts of the circuit, thereby improving the offset performance of the design. Separate the two bypass capacitors C_2 and C_3 as much as possible (even putting them on opposite sides of the PC board), while keeping the total lead lengths, including traces, of each bypass capacitor less than 20 mm. PC board traces should be made as short as possible and placed close together or over ground plane to minimize loop area and pickup of stray magnetic fields. Avoid using sockets, as they will typically increase both loop area and inductance. And finally, using capacitors with small body size and orienting them perpendicular to each other on the PC board can also help. For more information concerning this effect, see Application Note 1078, *Designing with Avago Technologies Isolation Amplifiers*.

Figure 26 Top Layer of Printed Circuit Board Layout



Figure 27 Bottom Layer of a Printed Circuit Board Layout



Shunt Resistor Selections

The current-sensing shunt resistor should have low resistance (to minimize power dissipation), low inductance (to minimize di/dt induced voltage spikes that could adversely affect operation), and reasonable tolerance (to maintain overall circuit accuracy). The value of the shunt should be chosen as a compromise between minimizing power dissipation by making the shunt resistance smaller and improving circuit accuracy by making it larger and utilizing the full input range of the HCPL-785x. Broadcom recommends four different shunts that can be used to sense average currents in motor drives up to 35A and 35 hp. Table 1 shows the maximum current and horsepower range for each of the LVR-series shunts from Dale. Even higher currents can be sensed with lower value shunts available from vendors such as Dale, IRC, and Isotek (Isabellenhuetten). When sensing currents large enough to cause significant heating of the shunt, the temperature coefficient of the shunt can introduce nonlinearity due to the signal dependent temperature rise of the shunt. Using a heat sink for the shunt or using a shunt with a lower tempco can help minimize this effect. The Application Note 1078, *Designing with Avago Technologies Isolation Amplifiers*, contains additional information on designing with current shunts.

The recommended method for connecting the isolation amplifier to the shunt resistor is shown in Figure 24. Pin 2 (V_{IN+}) is connected to the positive terminal of the shunt resistor, while pin 3 (V_{IN-}) is shorted to pin 4 (GND1), with the power-supply return path functioning as the sense line to the negative terminal of the current shunt. This allows a single pair of wires or PC board traces to connect the isolation amplifier circuit to the shunt resistor. In some applications, however, supply currents flowing through the power-supply return path may cause offset or noise problems. In this case, better performance may be obtained by connecting pin 3 to the negative terminal of the shunt resistor separate from the power supply return path. When connected this way, both input pins should be

bypassed. Whether two or three wires are used, it is recommended that twisted-pair wire or very close PC board traces be used to connect the current shunt to the isolation amplifier circuit to minimize electromagnetic interference to the sense signal.

The 68Ω resistor in series with the input lead forms a low-pass anti-aliasing filter with the input bypass capacitor with a 200 kHz bandwidth. The resistor performs another important function as well: it dampens any ringing that might be present in the circuit formed by the shunt, the input bypass capacitor, and the wires or traces connecting the two. Undampened ringing of the input circuit near the input sampling frequency can alias into the baseband producing what might appear to be noise at the output of the device. To be effective, the damping resistor should be at least 39Ω .

PC Board Layout

In addition to affecting offset, the layout of the PC board can also affect the common-mode rejection (CMR) performance of the isolation amplifier, due primarily to stray capacitive coupling between the input and the output circuits. To obtain optimal CMR performance, the layout of the printed circuit board (PCB) should minimize any stray coupling by maintaining the maximum possible distance between the input and output sides of the circuit and ensuring that any ground plane on the PCB does not pass directly below the HCPL-785x. Using surface-mount components can help achieve many of the PCB objectives discussed in the preceding paragraphs. An example through-hole PCB layout illustrating some of the more important layout recommendations is shown in Figure 26 and Figure 27. See Application Note 1078, *Designing with Avago Technologies Isolation Amplifiers*, for more information on PCB layout consideration.

Figure 28 Operating Circuit for Burn-In and Steady State Life Tests

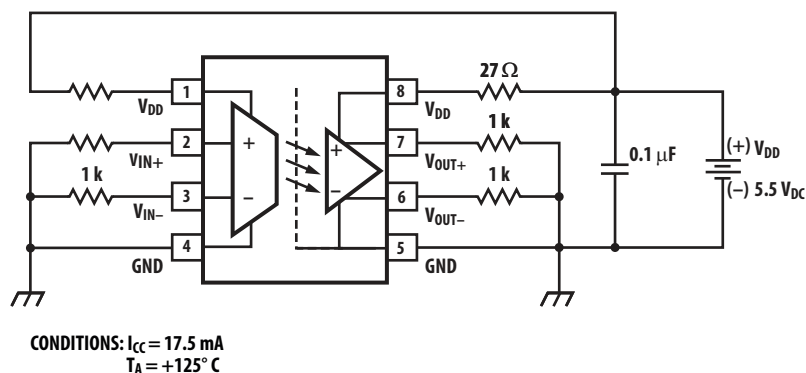

Post-Amplifier Circuit

The recommended application circuit (Figure 24) includes a post-amplifier circuit that serves three functions: to reference the output signal to the desired level (usually ground), to amplify the signal to appropriate levels, and to help filter output noise. The particular op-amp used in the post-amp is not critical; however, it should have low enough offset and high enough bandwidth and slew rate so that it does not adversely affect circuit performance. The offset of the op-amp should be low relative to the output offset of the HCPL-785x, or less than about 5 mV.

To maintain overall circuit bandwidth, the post-amplifier circuit should have a bandwidth at least twice the minimum bandwidth of the isolation amplifier, or about 200 kHz. To obtain a bandwidth of 200 kHz with a gain of 5, the op-amp should have a gain-bandwidth greater than 1 MHz. The post-amplifier circuit includes a pair of capacitors (C5 and C6) that form a single-pole low-pass filter. These capacitors allow the bandwidth of the post-amp to be adjusted independently of the gain and are useful for reducing the output noise from the isolation amplifier (doubling the capacitor values halves the circuit bandwidth). The component values shown in Figure 24 form a differential amplifier with a gain of 5 and a cutoff frequency of approximately 100 kHz, and were chosen as a compromise between low noise and fast response times. The overall recommended application circuit has a bandwidth of 66 kHz, a rise time of 5.2 μ s and a delay to 90% of 8.5 μ s.

The gain-setting resistors in the post-amp should have a tolerance of 1% or better to ensure adequate CMRR and gain tolerance for the overall circuit. Resistor networks with even better ratio tolerances can be used, which offer better performance, as well as reducing the total component count and board space.

The post-amplifier circuit can be easily modified to allow for single-supply operation. Figure 25 shows a schematic for a post amplifier for use in 5V single supply applications. One additional resistor is needed and the gain is decreased to 1 to allow circuit operation over the full input voltage range. See Application Note 1078, *Designing with Avago Technologies Isolation Amplifiers*, for more information on the post-amplifier circuit.

Other Information

As mentioned above, reducing the bandwidth of the post amplifier circuit reduces the amount of output noise. Figure 22 shows how the output noise changes as a function of the post-amplifier bandwidth. The post-amplifier circuit exhibits a first-order low-pass filter characteristic. For the same filter bandwidth, a higher-order filter can achieve even better attenuation of modulation noise due to the second-order noise shaping of the sigma-delta modulator. For more information on the noise characteristics of the HCPL-785x, see Application Note 1078, *Designing with Avago Technologies Isolation Amplifiers*.

The HCPL-785x can also be used to isolate signals with amplitudes larger than its recommended input range through the use of a resistive voltage divider at its input. The only restrictions are that the impedance of the divider be relatively small (less than 1 k Ω so that the input resistance (480 k Ω) and input bias current (0.6 μ A) do not affect the accuracy of the measurement. An input bypass capacitor is still required, although the 68 Ω series damping resistor is not. (The resistance of the voltage divider provides the same function.) The low-pass filter formed by the divider resistance and the input bypass capacitor may limit the achievable bandwidth.

Table 1 Current Shunt Summary

Shunt Resistor Part Number	Shunt Resistance	Maximum Power Dissipation	Maximum Average Current	Maximum Horsepower Range
LVR-3.05-1%	50 m Ω	3W	3A	0.8 to 3.0 hp
LVR-3.02-1%	20 m Ω	3W	8A	2.2 to 8.0 hp
LVR-3.01-1%	10 m Ω	3W	15A	4.1 to 15 hp
LVR-5.005-1%	5 m Ω	5W	35A	9.6 to 35 hp

For product information and a complete list of distributors, please go to our web site: www.broadcom.com.

Broadcom, the pulse logo, Connecting everything, Avago Technologies, Avago, and the A logo are among the trademarks of Broadcom in the United States, certain other countries and/or the EU.

Copyright © 2005-2017 Broadcom. All Rights Reserved.

The term "Broadcom" refers to Broadcom Limited and/or its subsidiaries. For more information, please visit www.broadcom.com.

Broadcom reserves the right to make changes without further notice to any products or data herein to improve reliability, function, or design.

Information furnished by Broadcom is believed to be accurate and reliable. However, Broadcom does not assume any liability arising out of the application or use of this information, nor the application or use of any product or circuit described herein, neither does it convey any license under its patent rights nor the rights of others.

AV02-3479EN – January 6, 2017

