

TAC/TAH series (4-30A)

TAC -10 -683 -□

① ② ③ ④

- ① Series Name
- ② Rated Current
- ③ Line to ground capacitor code: Refer to table 1.1.

table 1.1 Line to ground capacitor code

Code	Leakage Current (Input 250/500V 60Hz)	Line to ground capacitor (nominal value)
103	0.5mA/1.0mA max	10,000pF
223	1.0mA/2.0mA max	22,000pF
683	2.5mA/5.0mA max	68,000pF

* When the line to ground capacitor code is different, the attenuation characteristic is different.

- ④ Option
- D: DIN rail installation type

* The dimensions change when the option is set. Refer to External view.

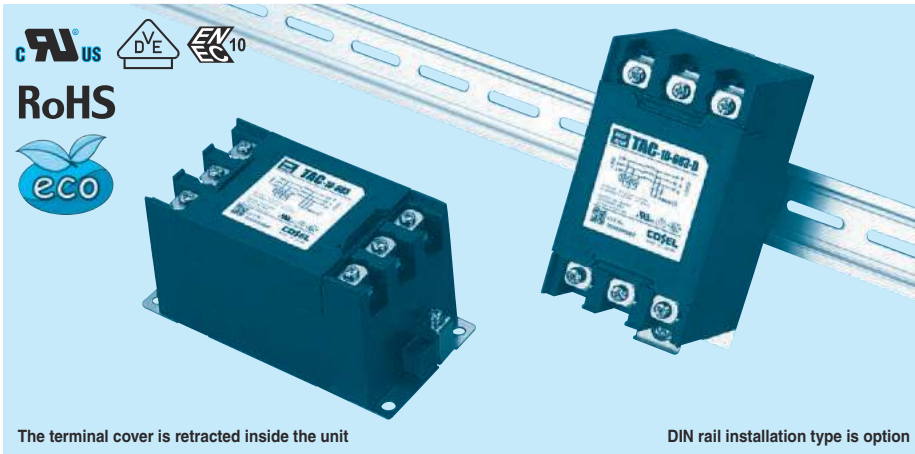

The terminal cover is retracted inside the unit

DIN rail installation type is option

Features of TAC/TAH series

- Three phase rated voltage 500VAC (voltage range:528V max) (1-Stage filter)
- Selectable leakage current value
- Quick and easy push-down terminal

Just connect the wires, push-down and tighten the screws with a screwdriver.

■ TAC: High-attenuation type from 150kHz to 1MHz

■ TAH: Ultra high-attenuation type from 9kHz to 1MHz

Specifications

No.	Items	TAC-04-683	TAC-06-683	TAC-10-683	TAC-20-683	TAC-30-683
		TAH-04-683	TAH-06-683	TAH-10-683	TAH-20-683	TAH-30-683
1	Rated Voltage[V]	AC Three Phase 500 (voltage range:528 max) 50/60Hz				
2	Rated Current[A]	4	6	10	20	30
3	Test Voltage (Terminal-Mounting Plate)	2,000 VAC (Cutoff Current = 100mA), 1minute at room temperature and humidity				
4	Isolation Resistance (Terminal-Mounting Plate)	500 VDC 100MΩ min at room temperature and humidity				
5	Leakage current	Refer to table 1.1				
6	Voltage drop	1.5V max		1.0V max		
7	Safety agency approval temperatures	-25 to +85°C (Refer to Derating Curve)				
8	Operating temperature	-40 to +85°C (Refer to Derating Curve)				
9	Operating humidity	20 to 95%RH (Non condensing)				
10	Storage temperature/humidity	-40 to +85°C/20 to 95%RH (Non condensing)				
11	Vibration	10 to 55Hz, 19.6m/s ² (2G), 3min. Period, 1hour each X, Y and Z axis				
12	Impact	196.1m/s ² (20G), 11ms Once each X, Y and Z axis				
13	Safety agency approvals	UL1283, CSA C22.2 No.8 (C-UL) , DIN EN60939 VDE0565 Teil3-1, ENEC				
14	Case size (without projection) /Weight	63×64×128 mm [2.48×2.52×5.04 inches] (W×H×D) / 620g max (Option : -D refer to external view)				

Circuit Diagram

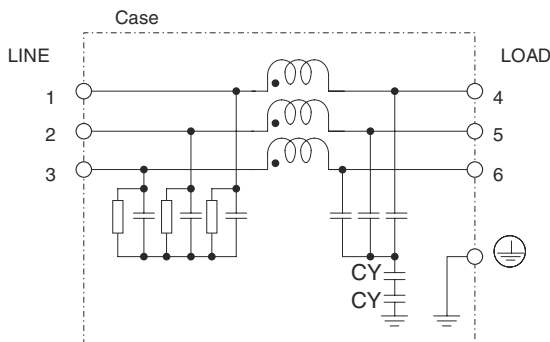

CY : Line to ground capacitor ⊥ : Mounting Plate

Derating Curve

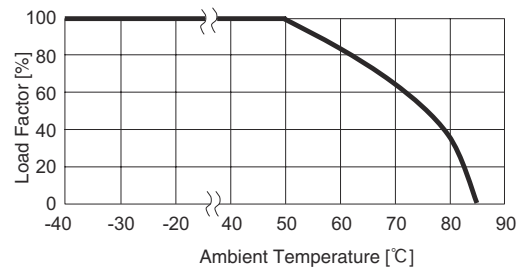

External view

This product is shipped in the following condition, because it is equipped with push-down terminals.

- ① The terminal cover is retracted inside the unit.
- ② The screws for connecting the terminals are held in the up right position.

Standard Type

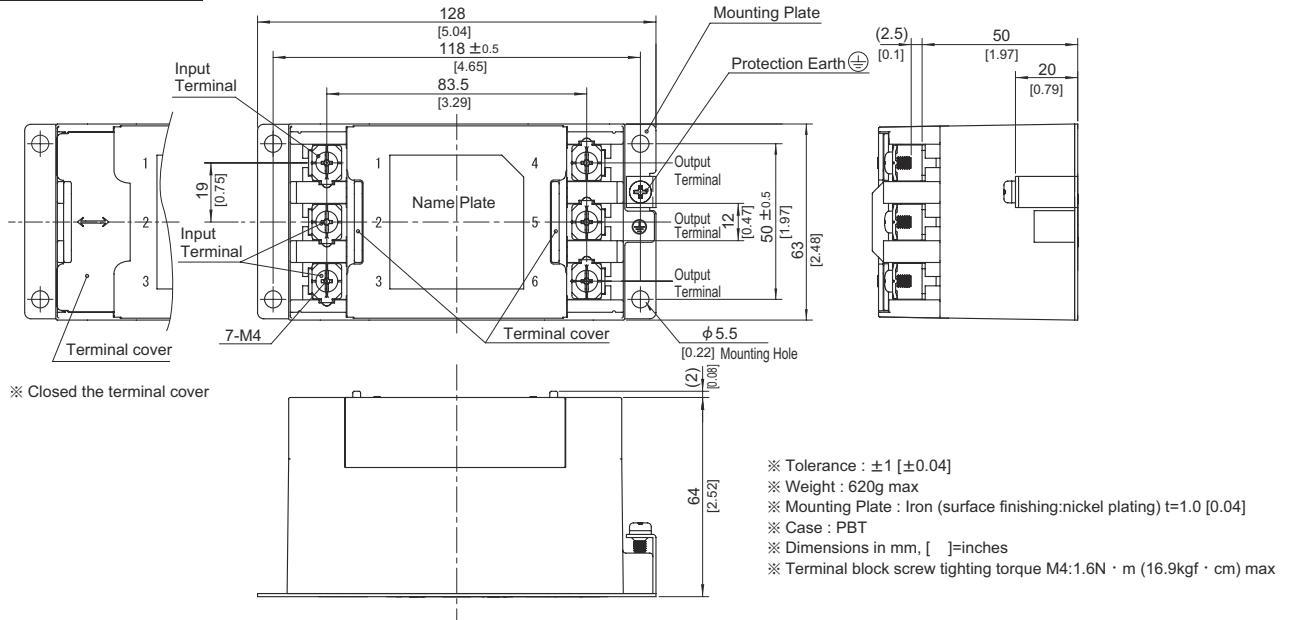

DIN rail installation Type

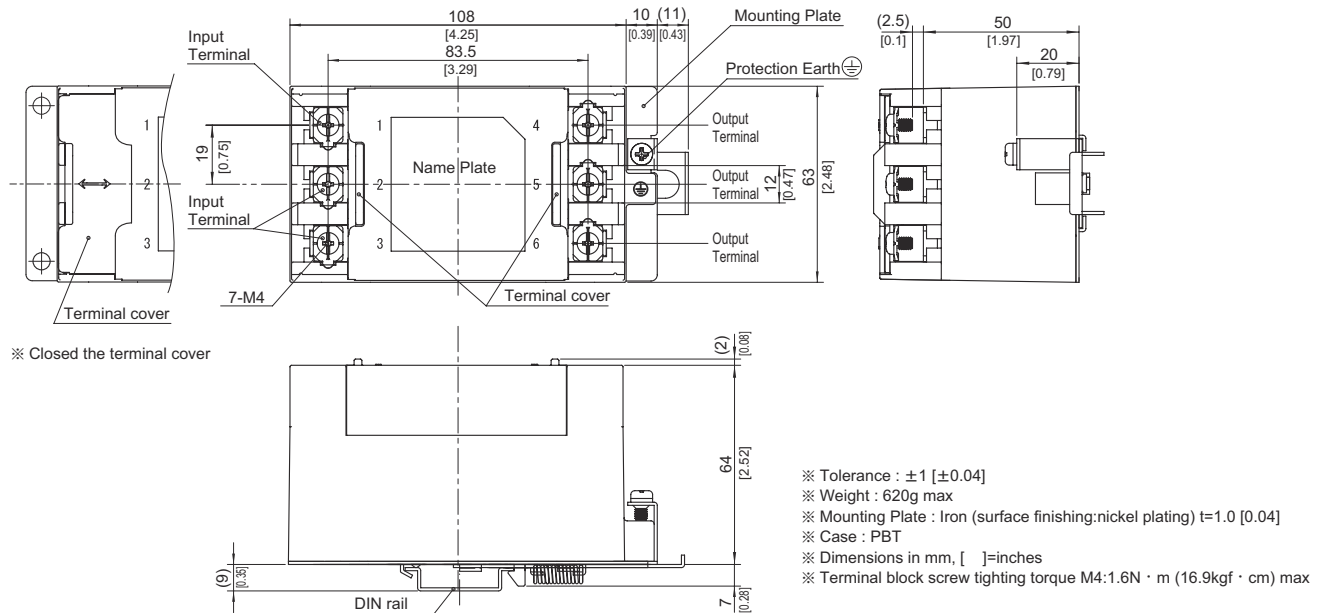

■Note when installing the EMI/EMC Filter on a DIN rail.

When the EMI/EMC Filter is grounded through the DIN rail, the proper noise attenuation may not be achieved.

Be sure to connect the protection earth (PE) of the EMI/EMC Filter body to the earth.

