

10 9 8 7 6 5 4 3 2 1

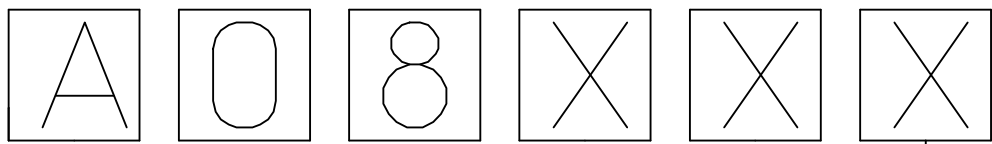

RODZAJ POLACZENIA/INTERNAL CIRCUIT
 PATRZ SCHEMATY POLACZEN/WIRING CONFIGURATION
 NAPIECIE ORAZ KOLOR DIODY/VOLTAGE AND LED COLOUR:

1= 12V	A= 12V	G= 12V	ZOLTA DIODA YELLOW LED
2= 24V	B= 24V	H= 24V	
3= 48V	C= 48V	K= 48V	
4= 115V	D= 115V	L= 115V	
5= 230V	E= 230V	M= 230V	

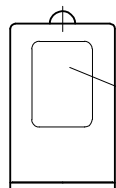

TAMPONADRUK SCHEMATU (BIALY)
 CIRCUIT TAMPOPRINT (WHITE)



TABELA 1 / CHART 1

MOLEX PN	ENGINEERING No
1210010277	A08A12
1210010280	A08A15
1210010291	A08C4B
1210010292	A08C4H
1210010294	A08C4M
1210010426	A08SOH
1210010428	A08A1L
1210010433	A08G2M
1210010439	A08C4L

SCHEMATY POLACZEN
 /WIRING CONFIGURATION

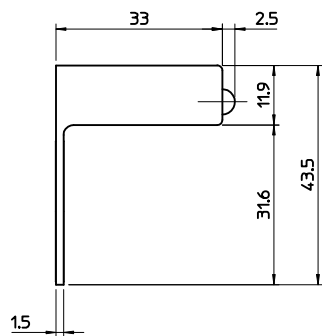
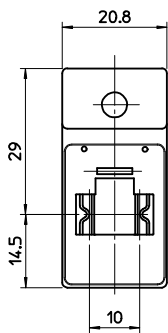
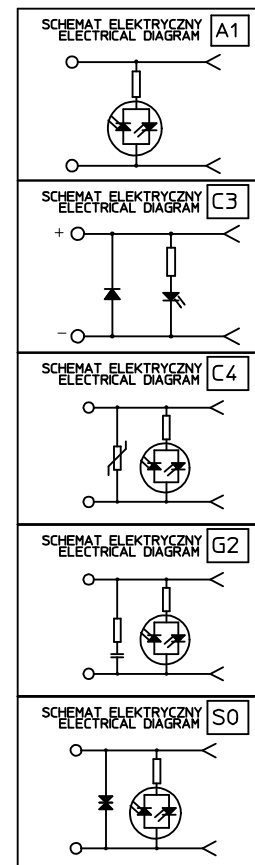

NEW PNs ADDED EC NO: IPG2016-1019 DRW:KALC IAK 2016/01/27 CHK:D-APAM LAK 2016/01/27 APPR:MIWAS IECZKO 2016/06/17	QUALITY SYMBOLS	GENERAL TOLERANCES (UNLESS SPECIFIED)	DIMENSION STYLE	SCALE	DESIGN UNITS	THIRD ANGLE PROJECTION
	▼=0 ◻=0	mm INCH	MM ONLY	---	METRIC	
	DESCRIPTION	4 PLACES ± --- ± ---	DRAWN BY DATE	TITLE		
	REV	3 PLACES ± --- ± ---	MLEVYTSKYY 2009/05/05	MPM A08 ADAPTORS		
		2 PLACES ± --- ± ---	CHECKED BY DATE	DOCUMENT NO.		
	1 PLACE ± --- ± ---	MDABROWSKA 2009/05/05	A08XXX			
	0 PLACE ± --- ± ---	APPROVED BY DATE	1 OF 1			
	ANGULAR ± --- °	MWOLSZCZAK 2009/05/05	THIS DRAWING CONTAINS INFORMATION THAT IS PROPRIETARY TO MOLEX INCORPORATED AND SHOULD NOT BE USED WITHOUT WRITTEN PERMISSION			
	DRAFT WHERE APPLICABLE MUST REMAIN WITHIN DIMENSIONS	MATERIAL NO.	SEE CHART 1			
		SIZE	A3			

9 8 7 6 5 4 3 2 1

A08 - ADAPTOR FOR DIN B

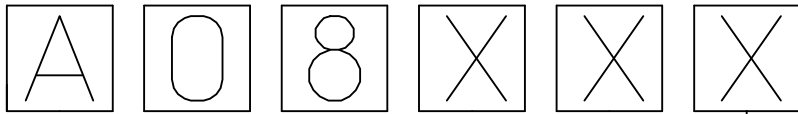

INTERNAL CIRCUIT

VOLTAGE AND LED COLOUR:

1= 12V	A= 12V	G= 12V
2= 24V	B= 24V	H= 24V
3= 48V	C= 48V	K= 48V
4= 115V	D= 115V	L= 115V
5= 230V	E= 230V	M= 230V

RED LED GREEN LED YELLOW LED

Chart 1

Engineering no.	SAP Part Number	Circuit type	LED Color
A08C4B	1210010291	C4 24V	Green
A08C4H	1210010292	C4 24V	Yellow
A08C4M	1210010294	C4 230V	Yellow
A08S0H	1210010426	S0 24V	Yellow
A08A1L	1210010428	A1 115V	Yellow
A08G2M	1210010433	G2 230V	Yellow
A08C4L	1210010439	C4 115V	Yellow

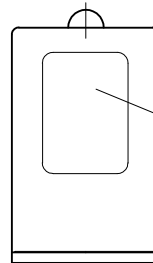

CIRCUIT TAMPOPRINT (WHITE)

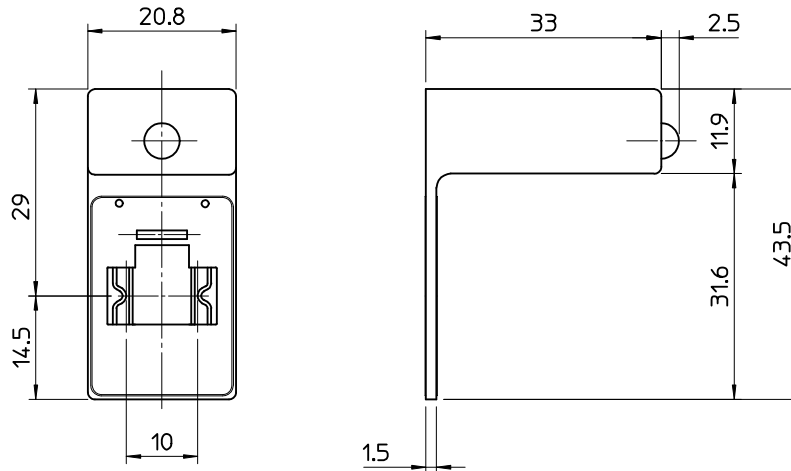

Wiring configuration

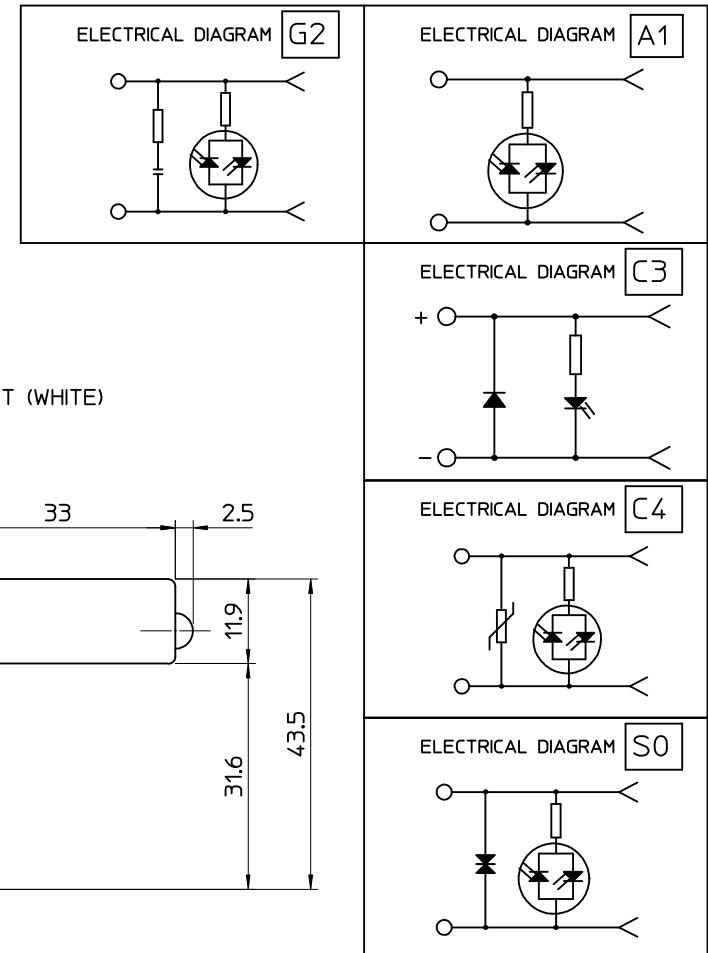

ORIGINAL RELEASE EC NO: IPG2013-1225 DRWN: JMARSZALEK 2013/02/11 CHKD: MSZWAJKOWSKI 2013/02/11 APPR: MIWASIECZKO 2013/02/12	QUALITY SYMBOLS ▽=0 ▽=0	GENERAL TOLERANCES (UNLESS SPECIFIED)		DIMENSION STYLE MM ONLY		SCALE -	DESIGN UNITS METRIC	FIRST ANGLE PROJECTION LIGHTS ADAPTORS SERIES A08XXX FOR DIN B molex	
				DRAWN BY DATE JMARSZALEK 2013/02/11		TITLE			
				CHECKED BY DATE MSZWAJKOWSKI 2013/02/11		DOCUMENT NO. SD-121001-008			
				APPROVED BY DATE MIWASIECZKO 2013/02/12		SHEET NO. 1 OF 1			
A	REV	ANGULAR ±---°		MATERIAL NO.		THIS DRAWING CONTAINS INFORMATION THAT IS PROPRIETARY TO MOLEX INCORPORATED AND SHOULD NOT BE USED WITHOUT WRITTEN PERMISSION			
		DRAFT WHERE APPLICABLE MUST REMAIN WITHIN DIMENSIONS		SEE CHART 1					