

THIS DRAWING IS UNPUBLISHED. RELEASED FOR PUBLICATION
 © COPYRIGHT - By - ALL RIGHTS RESERVED.

LOC		DIST		REVISIONS			
P	LTR	DESCRIPTION		DATE	DWN	APVD	
GP	00	L	REVISED PER ECO-12-021696	27FEB2013	CJV	SLB	

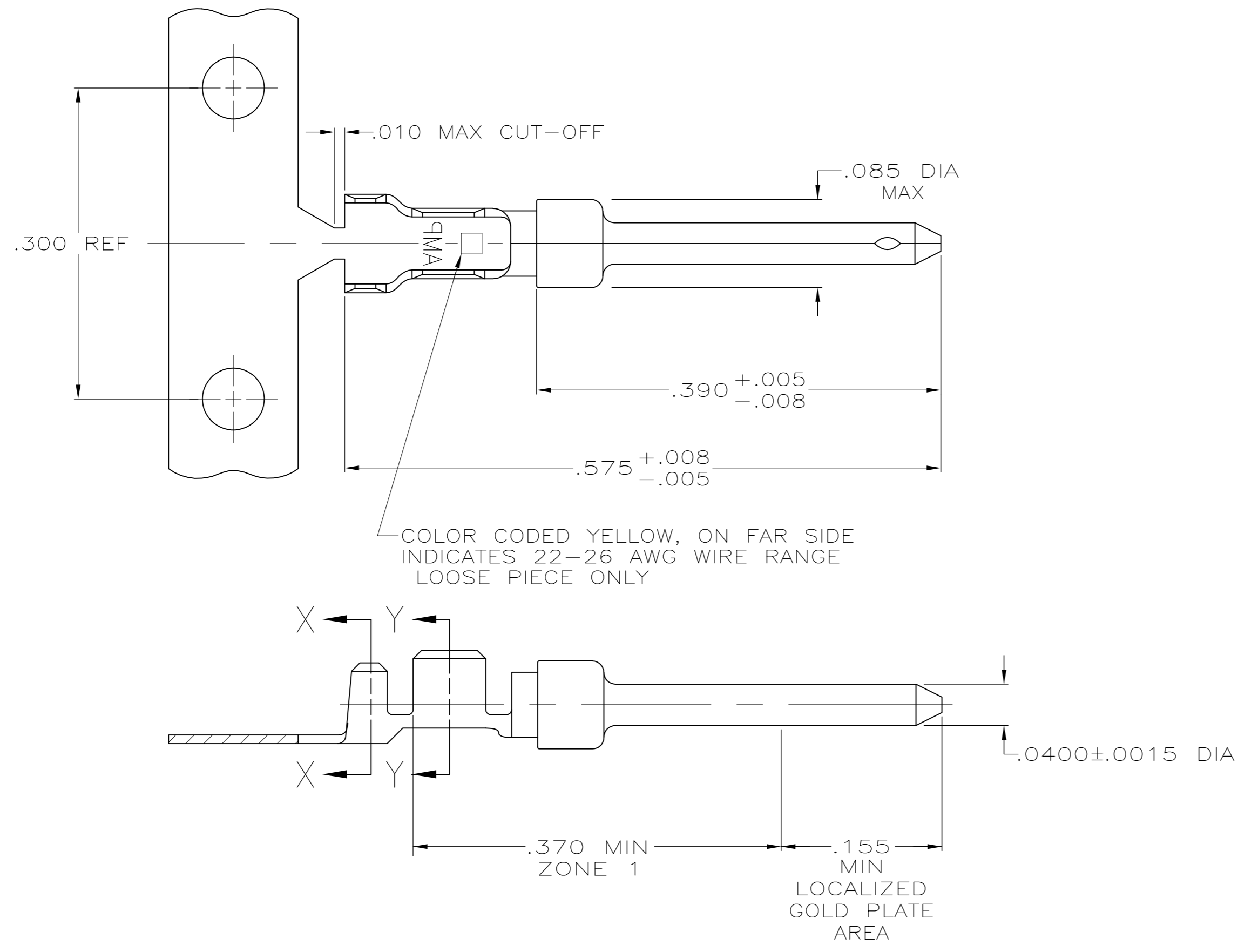

- 1 FOR MINI-APPLICATOR.
- 2 FOR HAND TOOL USE ONLY.
- 3. WIRE RANGE OF 22-26, INSULATION RANGE OF .040-.050.
- 4. GOLD PLATING MAY NOT APPEAR ON CARRIER STRIP. NICKEL UNDERPLATE COVERS ENTIRE CONTACT.
- 5 GOLD PLATING PER MIL-G-45204. NICKEL PLATING PER QQ-N-290. TIN PLATING PER MIL-T-10727.
- 6 GOLD PLATED IN LOCALIZED GOLD PLATE AREA AS FOLLOWS: .000030 MIN GOLD IN MATED AREA, GOLD FLASH ON REMAINDER OF LOCALIZED GOLD PLATE AREA AND ZONE 1 OF CONTACT, ALL OVER .000050 MIN NICKEL UNDERPLATE.
OR
GOLD FLASH OVER PALLADIUM-NICKEL PLATE, .000030 MIN TOTAL IN MATED AREA, GOLD FLASH ON REMAINDER OF LOCALIZED GOLD PLATE AREA AND ZONE 1 OF CONTACT, ALL OVER .000050 MIN NICKEL UNDERPLATE.
- 7 .000001 MIN GOLD ON LOCALIZED GOLD PLATE AREA AND ZONE 1 OVER .000030 MIN NICKEL.
- 8 GOLD PLATED IN LOCALIZED GOLD PLATED AREA, .000001 MIN GOLD IN MATED AREA, TIN PLATED WIRE BARRELS, OVER .000030 NICKEL.
- 9 GOLD PLATED IN LOCALIZED GOLD PLATED AREA, .000030 GOLD IN MATED AREA, TIN PLATED WIRE BARRELS, OVER .000050 NICKEL.

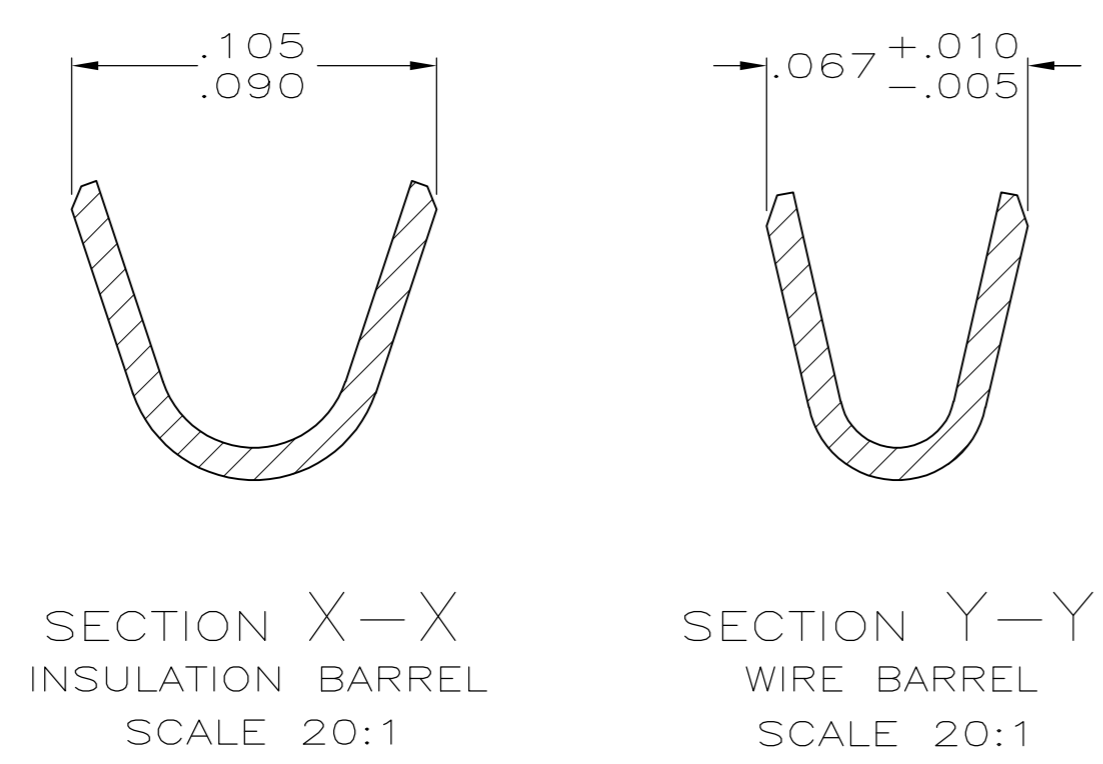

OBSELETE	SMALL PACK	7	2	LOOSE PIECE	1-745254-7
OBSELETE	STANDARD	9	2	LOOSE PIECE	1-745254-6
OBSELETE	STANDARD	9	1	STRIP	1-745254-4
OBSELETE	STANDARD	8	2	LOOSE PIECE	1-745254-3
OBSELETE	STANDARD	8	1	STRIP	1-745254-1
	STANDARD	7	2	LOOSE PIECE	745254-7
	STANDARD	6	2	LOOSE PIECE	745254-6
	STANDARD	7	1	STRIP	745254-3
	STANDARD	6	1	STRIP	745254-2
PACKAGING TYPE		FINISH	USE	TYPE	PART NUMBER

THIS DRAWING IS A CONTROLLED DOCUMENT. DIMENSIONING AND TOLERANCING PER ASME Y14.5M-2009

DWN S.WELDON 9-9-86
 CHK C.RICHARD 9-9-86
 APVD V. KUMAR 9-10-86
 PRODUCT SPEC
 APPLICATION SPEC 114-10000

MATERIAL BRASS PER MIL-C-50
 FINISH 5 SEE TABLE

TE Connectivity
 PIN CONTACT, SIZE 20 DF, 22-26 AWG, W/.040-.050 DIA INSULATION SUPPORT

SIZE A2 CAGE CODE 00779 DRAWING NO C=745254 RESTRICTED TO -
 SCALE 10:1 SHEET 1 of 1 REV L