

Features

- Dome lens provides intensified narrow, bright beam
- Available for both standard and reverse mounting
- Wider operating temperature: -40° ~ +100°C
(HBG: -40° ~ +85°C)

Applications

- High-beam indicator for automotive use
- Backlighting for automotive dashboards
- Indoor / outdoor full-color signboards

Outline Dimensions

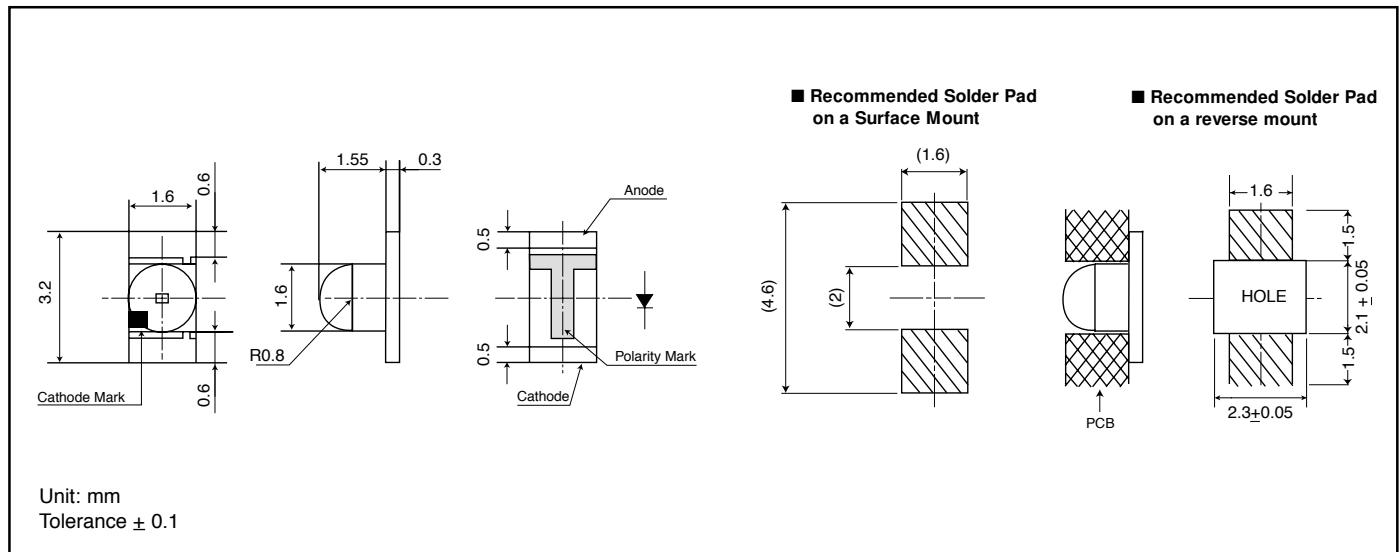

Electro-Optical Characteristics

(Ta=25°C)

Part No.	Material	Emitted Color	Lens Color	Luminous Intensity I _v			Wavelength				Forward Voltage V _f			Reverse Current I _r		Viewing Angle (2θ 1/2)
				MIN.	TYP.	I _f	Peak λ _p TYP.	Dominant λ _d TYP.	Spectral Line Half Width Δλ TYP.	I _f	TYP.	MAX.	I _f	MAX.	V _r	
HKR1105W	GaAlAs	Red	Water Clear	70	150	20	660	647	25	20	1.8	2.5	20	100	4	30°
HBR1105W	GaAlAs	Red		25	50	20	660	647	30	20	1.7	2.0	20	100	4	50°
HAA1105W	GaAsP	Orange		10	20	20	605	606	30	20	2.2	2.5	20	100	4	40°
HAY1105W	GaAsP	Yellow		10	20	20	580	590	30	20	2.2	2.5	20	100	4	
HPY1105W	GaP	Yellow-Green		20	50	20	570	572	30	20	2.1	2.5	20	100	4	
HPG1105W	GaP	Green		15	30	20	560	567	30	20	2.1	2.5	20	100	4	
HBG1105W	GaP	Pure Green		6	12	20	555	558	30	20	2.1	2.5	20	100	4	
Units				mcd	mA		nm		mA		V	mA		μA	V	Deg.

Absolute Maximum Ratings

(Ta=25°C)

Item	Symbol	Red	Orange	Yellow	Yellow-Green	Green	Pure Green	Units	
		HBR, HKR	HAA	HAY	HPY	HPG	HBG		
Power Dissipation	Pd	60(HBR),75(HKR)	75	75	75	75	75	mW	
Forward Current	I _F	30	30	30	30	30	30	mA	
Peak Forward Current	I _{FM}	70	70	70	70	70	70	mA	
Reverse Voltage	V _R	4	4	4	4	4	4	V	
Operating Temperature	Topr	-40 to +100					-40 to +85		°C
Storage Temperature	Tstg	-40 to +120					-40 to +100		°C
Derating*	ΔI _F	1.0 (DC) 2.33 (Pulse)					0.42 (DC) 0.93 (Pulse)		mA/°C

* Ta=25°C, I_{FM} applies for the pulse width ≤ 1msec. and duty cycle ≤ 1/20.

The current derating for operation applies when the temperature is above 25°C for HBG and 75°C for HVR, HBR, HKR, HAA, HAY, HPY & HPG

Taping Specifications

for Reverse Mount Type

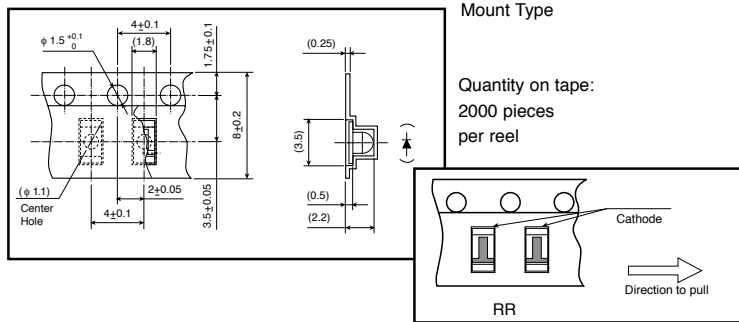

Taping Specifications

for Standard Mount Type

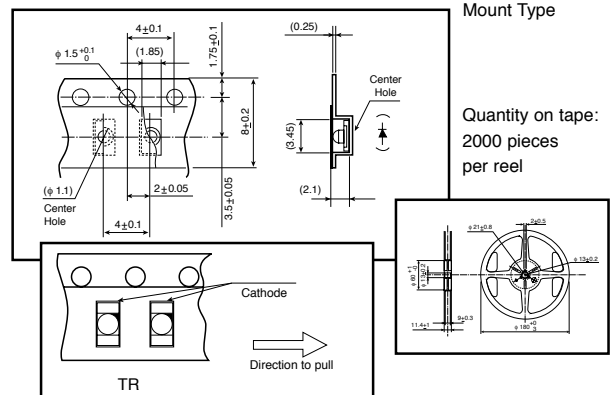

Operation Current Derating Chart (DC)

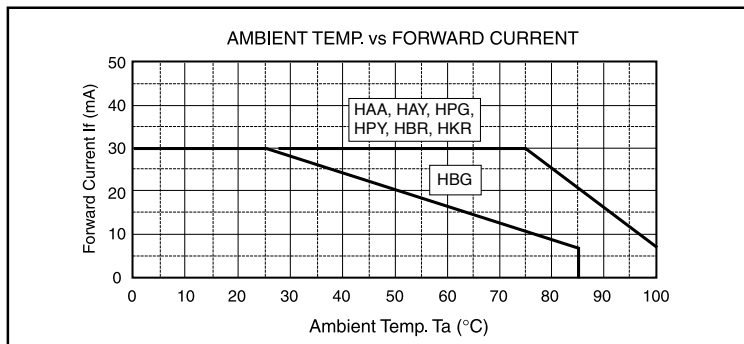

Spatial Distribution

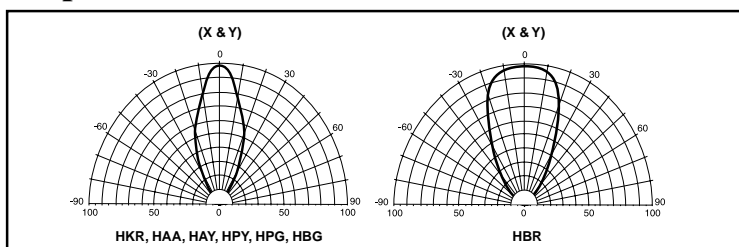

Precautions

Please follow these handling precautions to prevent damage to the chip and ensure its reliability.

1. Soldering conditions:

- **Soldering iron:** Temperature at tip of iron: 280°C max. (30W max.) Soldering time: 3 sec. max.
- **Dip soldering:** Preheating: 120 ~ 150°C max. (resin surface temp.) 60 ~ 120 sec. max. Bath temperature: 260°C max. Dipping Time: 5 sec. max.
- **Reflow Soldering:**

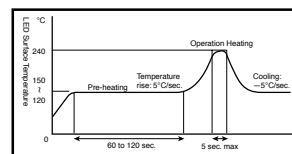

2. Cleaning:

- If cleaning is required, use the following solutions for less than 1 minute, at less than 40°C.
- Appropriate chemicals: Ethyl alcohol and isopropyl alcohol.
- Effect of ultrasonic cleaning on the LED resin body differs depending on such factors as the oscillator output, size of PCB and LED mounting method. The use of ultrasonic cleaning should be enforced at proper output after confirming there is no problem.

Product specifications subject to change without notice. PGH_1105W-0301

Stanley Electric Sales of America, Inc.

2660 Barranca Parkway, Irvine, CA 92606 • Tel: 800-LED-LCD1 (533-5231) • Fax: 949-222-0555
Website: www.stanley-electric.com