

REVISIONS					
P	LTR	DESCRIPTION	DATE	DWN	APVD
F3		REVISED PER ECN-22-150900	28APR2022	RK	CSD

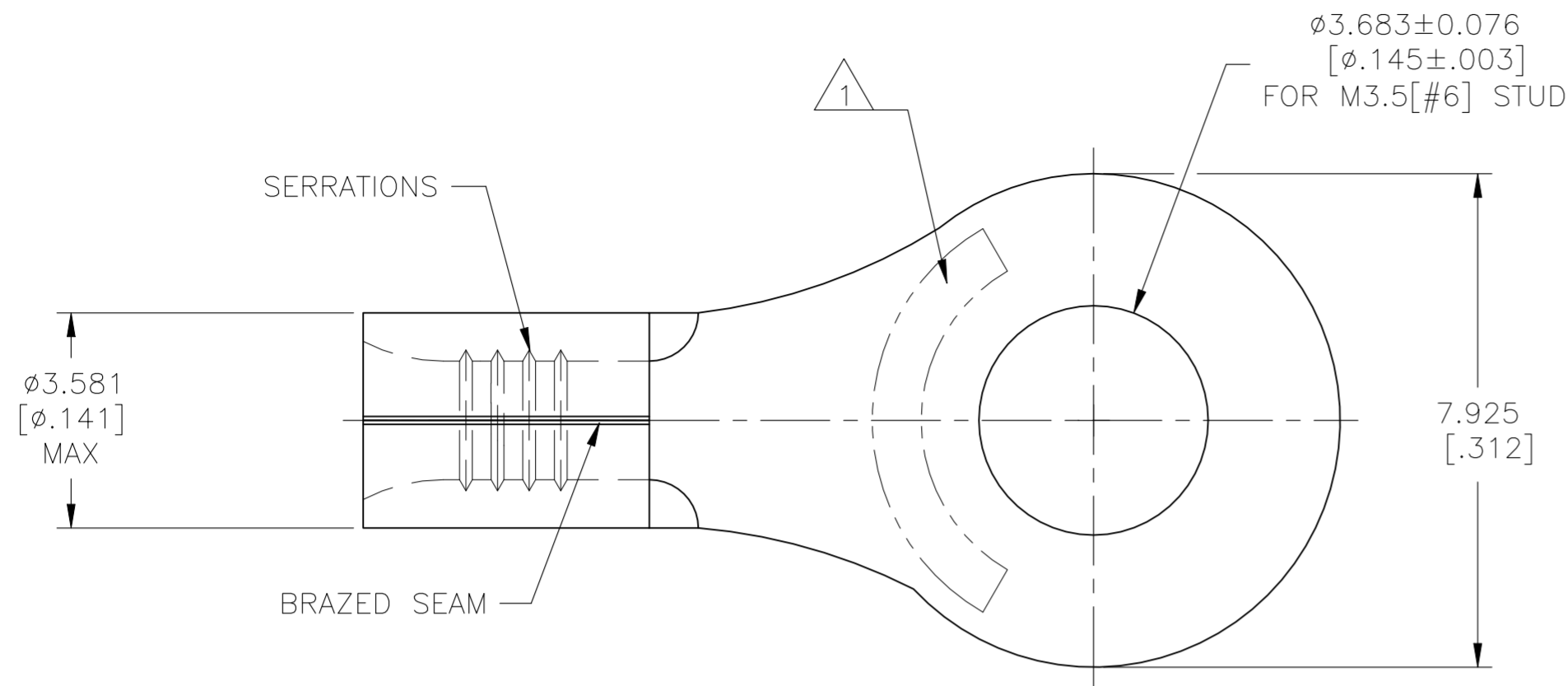

<b>AMP</b> WIRE RANGE	E13288 Listed
22-16 AWG SOLID OR STRANDED	22-16 AWG SOLID OR STRANDED

LR7189 Certified
22-16 AWG SOLID OR STRANDED

- △1 STAMP AMP 22-18\* APPROX AS SHOWN  
22-16 TERMINALS ARE STAMPED 22-18 IN  
ACCORDANCE WITH MILITARY SPECIFICATION  
SAE AS7928 COMMERCIAL WIRE RANGE IS 22-16
- △2 UL 486 A-B

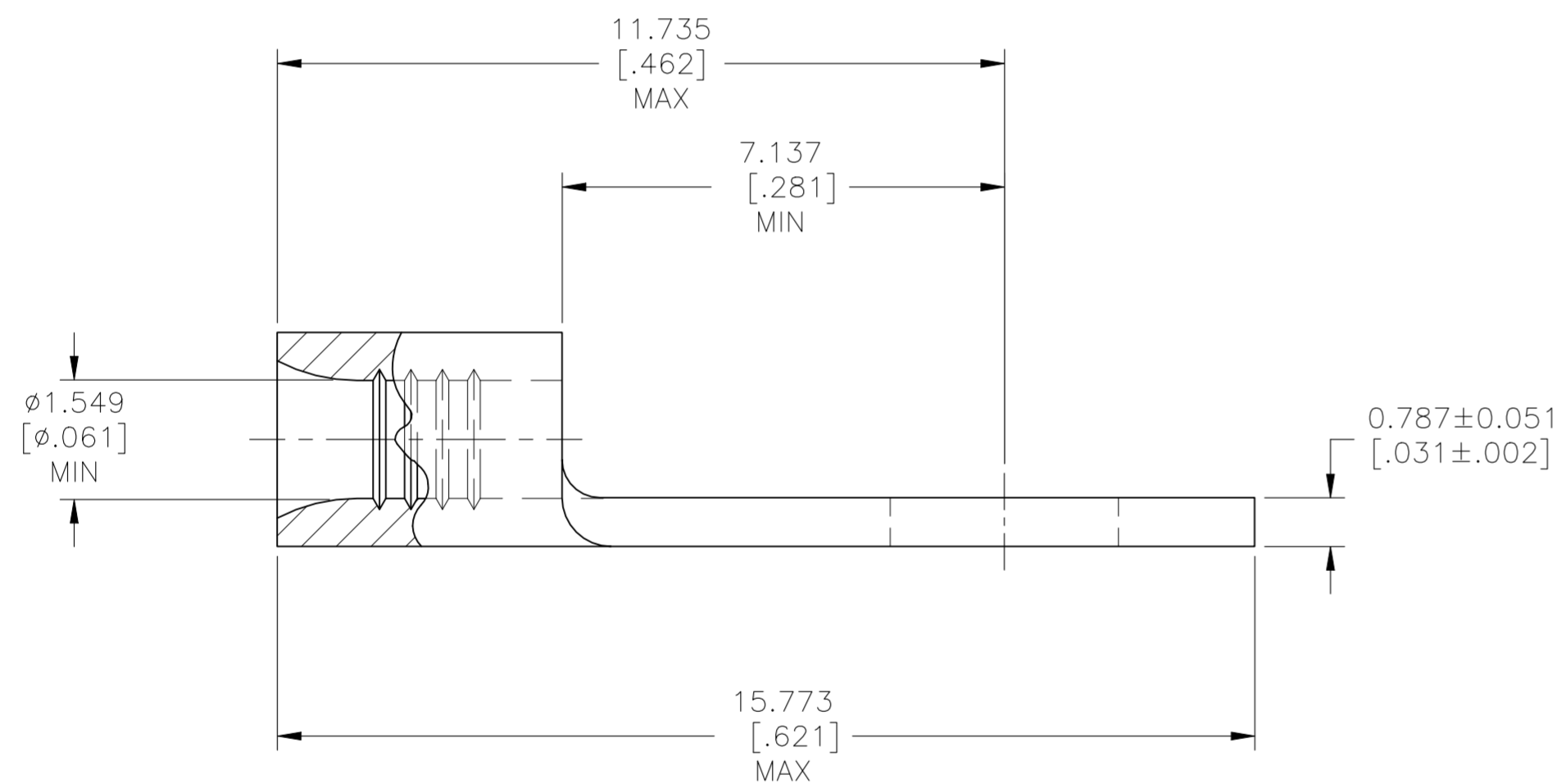

<b>AMP INCORPORATED CUSTOMER SERVICE SYSTEMS</b>		MAX RECOMMENDED OPERATING TEMPERATURE: 170° C[338°F] MAX
FOR ADDITIONAL PRODUCT INFORMATION OR COPIES OF DRAWINGS AND TECHNICAL DOCUMENTS	PRODUCT INFORMATION CENTER 1-800-522-6752	VOLTAGE RATING: NOT APPLICABLE
FOR APPLICATION TOOLING INFORMATION	TOOLING ASSISTANCE CENTER 1-800-722-1111	WIRE CROSS SECTIONAL AREA RANGE: 0.26-1.65mm <sup>2</sup> [509-3,260] CIR MILS SOLID OR STRANDED
FOR ORDER ENTRY	1-800-526-5142	THIS DRAWING IS A CONTROLLED DOCUMENT FOR AMP INCORPORATED. IT IS SUBJECT TO CHANGE AND THE CONTROLLING ENGINEERING ORGANIZATION SHOULD BE CONTACTED FOR THE LATEST REVISION.

5000	ON TAPE	2-34110-3
1000	LOOSE PIECE	34110
QUANTITY	PACKAGE TYPE	PART NO

THIS DRAWING IS A CONTROLLED DOCUMENT.		DWN TA BRINKMAN 3-10-93	TE Connectivity	
DIMENSIONS: mm [INCHES]		CHK DA PATTERSON 3-10-93		
TOLERANCES UNLESS OTHERWISE SPECIFIED:		APVD DE MILLER 3-10-93	NAME TERMINAL, RING TONGUE, SOLISTRAND 22-16 AWG	
0 PLC ± - 1 PLC ± - 2 PLC ± - 3 PLC ± 0.127[.005] 4 PLC ± - ANGLES ± -		PRODUCT SPEC APPLICATION SPEC	SIZE A2	
MATERIAL COPPER PER ASTM B-152 ANNEALED		FINISH TIN PLATE 0.00254[.000100] MIN THK PER ASTM B545	WEIGHT -	CAGE CODE 00779
		RESTRICTED TO -	DRAWING NO C=34110	SCALE 10:1
		CUSTOMER DRAWING	SHEET 1 of 1	REV F3