

UNIT : mm

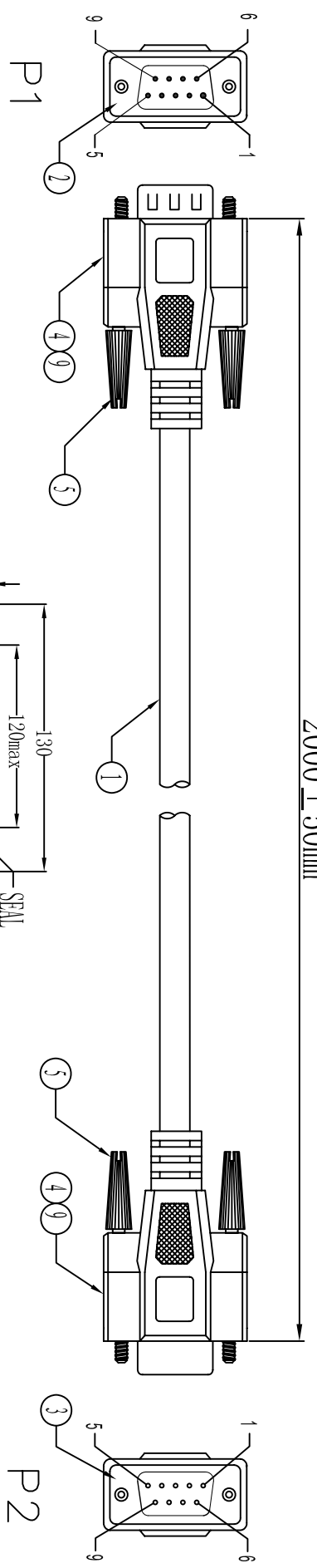

Electronic Test:
 1. 100% Test, (Open, Short, Miss Wire)
 2. Contact Resistance: 2 ohm max.
 3. Insulation Resistance: 5M ohm min.
 4. Hi-Pot: 100V DC/10ms

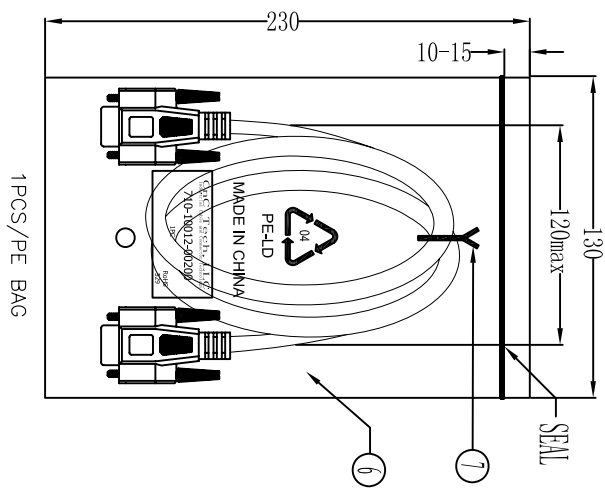

PIN ASSIGNMENT

P1	1	BLACK	P2	1
	2	GREY		2
	3	YELLOW		3
	4	PURPLE		4
	5	ORANGE		5
	6	RED		6
	7	BROWN		7
	8	GREEN		8
	9	BLUE		9
SHELL		D.W	SHELL	

⑨	TUBE	2	HEAT SHRINK TUBE BLACK OD1.5*1.5MM
⑧	PE BAG	1/10	CLEAR SIZE:280*330*0.05mm PRINT BLACK"MADE IN CHINA"+"10PCS"
⑦	TIE	1	WHITE L=120mm
⑥	PE BAG	1	CLEAR SIZE:130*230*0.05mm PRINT BLACK"MADE IN CHINA"
⑤	SCREW	4	SCREW:#4-40UNC L47mm,NICKEL PLATED,INSULATION COLOR BEIGE(V-29)
④	OUT JACKET	43.5g	BEIGE(V-29) 40P PVC(MOULD NO:WM-113)
③	IN JACKET	8g	CLEAR LDPE(MOULD NO:NM-049)
②	CONN	1	DB 9PIN FEMALE PIN G/F SHELL-NICKEL SOLDER TYPE INSULATION COLOR BLUE
①	CABLE	1	NOUL 28AWG*9C+D+W+AL/MV+JACKET COROL:BEIGE(V-29) OD:5.0mm. L2000±10mm.

CNC Tech, LLC
 Industrial Cable and Connector Technology

DRAWN BY	ZHONGHSH	DRAWING NO.	
CHECKED BY		CUSTOMER	
APPROVAL BY		ITEM NO.	710-10012-00200
DECIDE BY		DATE	2012-02-06
VERSIONS/EDITION	A/0	PROJECTION	