



## Evaluating the **AD5675/AD5675R** Octal, 16-Bit *nanoDAC+*

### FEATURES

Full featured evaluation board for the **AD5675/AD5675R**  
Various link options  
PC control in conjunction with the Analog Devices, Inc.,  
**EVAL-SDP-CB1Z** system demonstration platform (SDP)

### EVALUATION KIT CONTENTS

**AD5675/AD5675R** evaluation board

### ADDITIONAL EQUIPMENT AND SOFTWARE NEEDED

**EVAL-SDP-CB1Z** SDP board, includes a USB cable  
Bench power supply (6 V dc)  
PC running Windows 7 or later with USB 2.0 port

### ONLINE RESOURCES

#### Documents Needed

**AD5675/AD5675R** data sheet  
**EVAL-AD5675SDZ/EVAL-AD5675RSDZ** user guide

#### Required Software

**ACE** software

### GENERAL DESCRIPTION

This user guide details the operation of the evaluation boards for the **AD5675/AD5675R** octal channel, voltage output digital-to-analog converters (DACs).

The **EVAL-AD5675SDZ/EVAL-AD5675RSDZ** evaluation boards help customers to quickly prototype new **AD5675/AD5675R** circuits and reduce design time. The **AD5675/AD5675R** operate from a single 2.7 V to 5.5 V supply. The **AD5675R** has an internal 2.5 V reference giving a maximum output voltage of 2.5 V or 5 V. The **AD5675** does not have an internal reference; therefore, an **ADR431** is provided on-board as a 2.5 V reference source. A different reference voltage can be applied via the EXT\_REF SMB connector, if required.

Full data on the **AD5675/AD5675R** are available in the respective product data sheets, available from Analog Devices, which should be consulted in conjunction with this user guide when using the evaluation boards.

The evaluation boards interface to the USB port of a PC via the SDP board. The Analysis Control Evaluation (ACE) software is available for use with the evaluation board to allow the user to program the **AD5675/AD5675R**.

The evaluation boards are compatible the **EVAL-SDP-CB1Z** Blackfin® SDP controller board (**SDP-B**), which is available for order on the Analog Devices website at [www.analog.com](http://www.analog.com).

**TABLE OF CONTENTS**

Features .....	1	Memory Map .....	6
Evaluation Kit Contents.....	1	Evaluation Board Hardware.....	7
Additional Equipment and Software Needed.....	1	Power Supplies.....	7
Online Resources .....	1	Input Signals.....	7
General Description .....	1	Output Signals .....	7
Revision History .....	2	Link Configuration Options .....	8
Typical Evaluation Setup .....	3	Setup Conditions.....	8
Getting Started .....	4	Evaluation Board Circuitry .....	9
Installing the Software .....	4	Evaluation Board Schematics.....	10
Initial Set Up .....	4	Bill of Materials.....	12
Block Diagram And Description.....	5		

**REVISION HISTORY**

**5/2017—Rev. 0 to Rev. A**

Changes to Features Section, Additional Equipment and Software Needed Section, Online Resources Section, and General Description Section .....	1
Changes to Installing the Software Section, Changed Evaluation Board Setup Procedures Section to Initial Set-Up Section .....	4
Added Figure 3 and Figure 4; Renumbered Sequentially .....	4
Added Block Diagram and Description Section and Figure 4 .....	5
Added Table 1; Renumbered Sequentially .....	5
Added Memory Map Section, Figure 5, and Figure 6 .....	6
Deleted How to Use the Software Section.....	8

**3/2015—Revision 0: Initial Version**

# TYPICAL EVALUATION SETUP

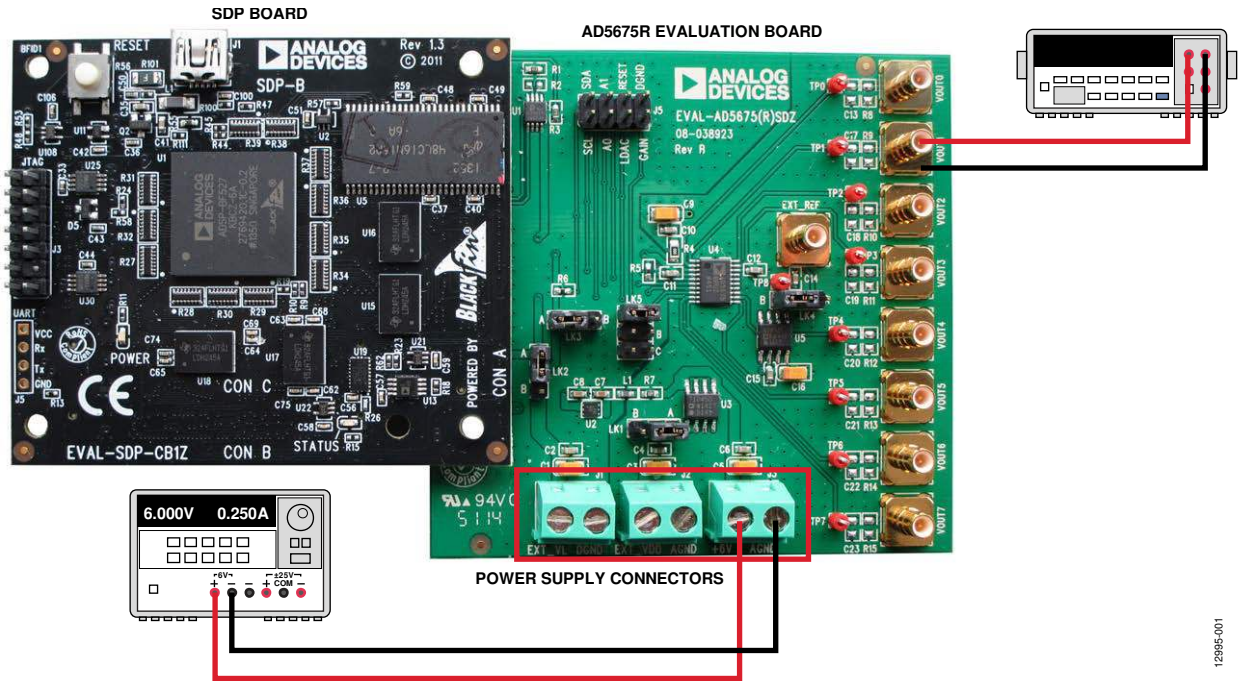

Figure 1.

12995-001

## GETTING STARTED

### INSTALLING THE SOFTWARE

The [EVAL-AD5675SDZ](#) and [EVAL-AD5675RSDZ](#) evaluation boards use the Analog Devices ACE software. ACE is a desktop software application that allows the evaluation and control of multiple evaluation systems.

The ACE installer installs necessary SDP drivers and .NET Framework 4 by default. Install ACE before connecting the SDP board to the USB port of the PC to ensure that the SDP board is recognized when it connects to the PC. Use the following link to download the software, and access full instructions on how to install and use this software: <http://www.analog.com/ace>.

After the installation is finished the [EVAL-AD5675SDZ](#) and [EVAL-AD5675RSDZ](#) evaluation board plug-ins appear when you open ACE.

### INITIAL SETUP

To set up the evaluation board, take the following steps:

1. Connect the evaluation board to the [SDP-B](#) board and connect the USB cable between the [SDP-B](#) board and the PC.
2. Power the [SDP-B](#) and evaluation board by connecting 6 V dc to the J3 connector.
3. Run the ACE application. The [EVAL-AD5675SDZ](#)/[EVAL-AD5675RSDZ](#) board plug-ins appear in the attached hardware section of the Start tab.
4. Double-click on the board plug-in to open the board view seen in Figure 2.
5. The chip block diagram can be accessed by double-clicking on the [AD5675](#) or [AD5675R](#) chip. This view provides a basic representation of functionality of the board. The main functions are labeled in Figure 3.

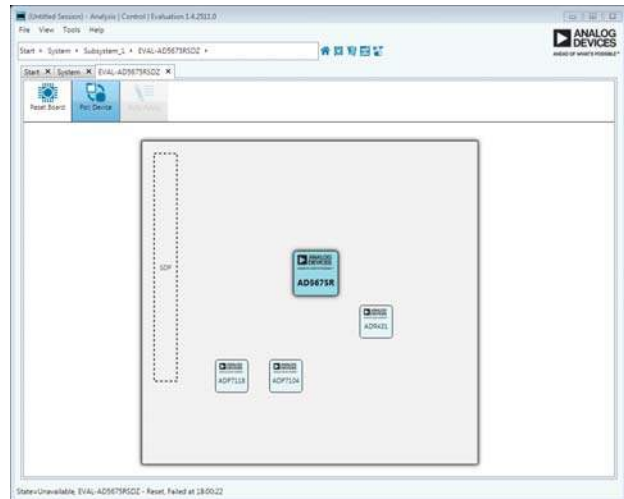

Figure 2. Board View of the [EVAL-AD5675RSDZ](#)

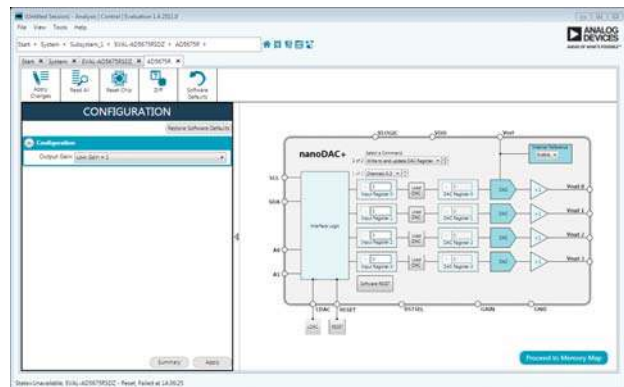

Figure 3. Chip Block Diagram view for the [AD5675R](#)

## BLOCK DIAGRAM AND DESCRIPTION

The EVAL-AD5675SDZ/EVAL-AD5675RSDZ software is organized so that it appears similar to the functional block diagram shown in the data sheets. This way, it is easy to correlate the functions on the board with the description in the data sheets. A full description of each block, register, and its settings is given in the AD5675/AD5675R data sheets.

Some of the blocks and their functions are described here as they pertain to the evaluation board. The full screen block diagram shown in Figure 4 and Table 1 describes the functionality of each block.

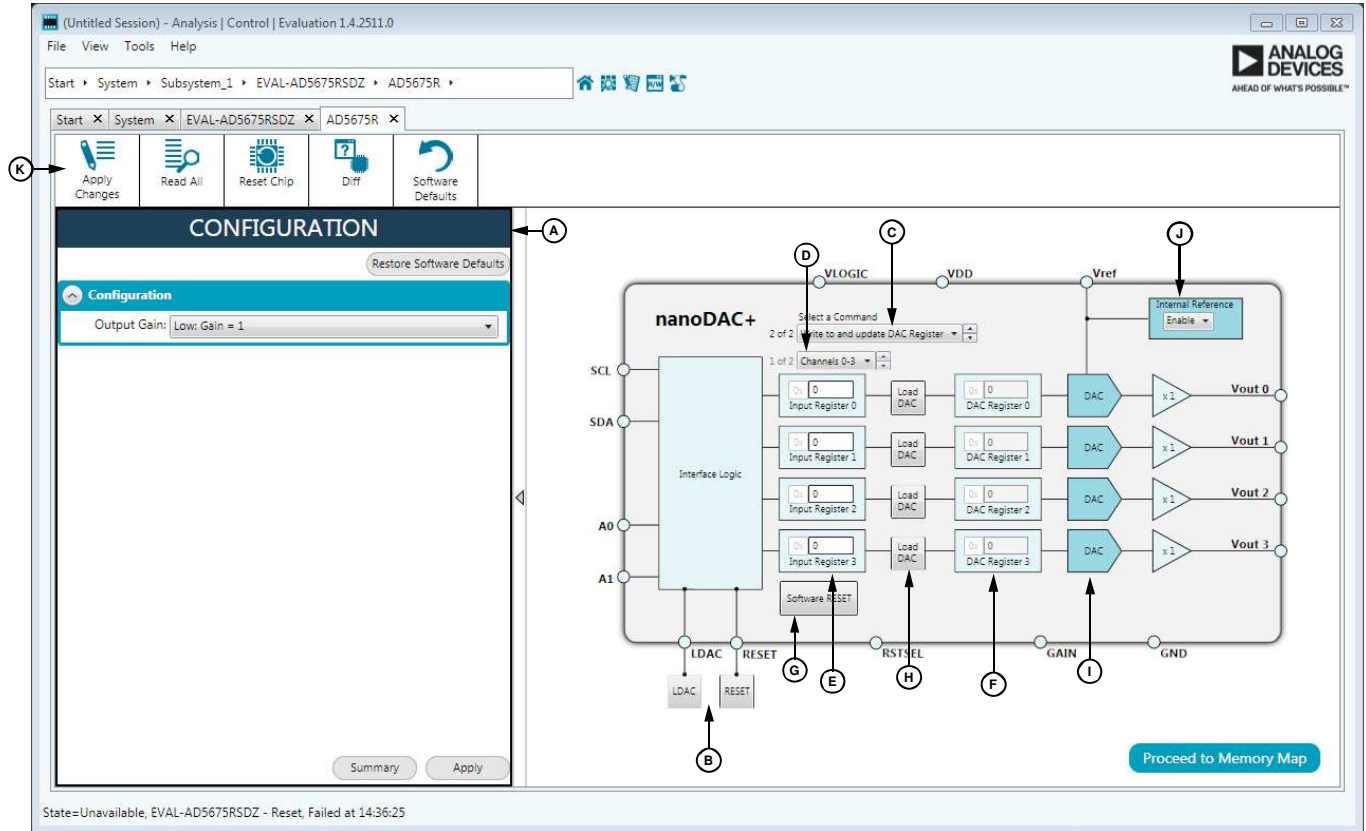

Figure 4. Block Diagram with Labels

Table 1. Block Diagram Functions

Label	Function
A	The configuration wizard sets up the initial configuration for the board. From the <b>Output Gain</b> drop-down menu, the reference gain case be selected. A gain of 1 is the default. After setting up the initial configuration, click <b>Apply</b> and the values are applied. These settings can be modified at any stage while testing.
B	The <b>GPIO</b> buttons act as external GPIO pulses to the <b>LDAC</b> and <b>RESET</b> pins. The <b>LDAC</b> button pushes data from both input registers (E) to the DAC registers (F). The <b>RESET</b> button clears all data from input registers and DAC registers. These buttons are live, so there is no need to click <b>Apply Changes</b> (K).
C	The <b>Command Option</b> drop-down menu selects how the data being transferred to the device affects the Input and DAC registers. After a data value is entered in an input register (see E), this menu determines if the data is transferred to the input register only, or to the channel input register (E) and channel DAC register (F).
D	The <b>Change Page Display</b> drop-down menu selects which page of 4 DAC channel settings are displayed
E	The input registers transfer 16-bit data word to the device. Upon clicking the <b>Apply Changes</b> (K), this 16-bit data word is transferred to the device.
F	The <b>DAC registers</b> display the value that is currently present in the DAC register on the device. The DAC registers can be updated by selecting the appropriate command option or by toggling <b>LDAC</b> (B).
G	<b>Software reset</b> returns the board and software to default values. This button is live, so there is no need to click <b>Apply Changes</b> .
H	The <b>Load LDAC</b> buttons per channel control to control the loading of Input Register contents to the DAC Register.

Label	Function
I	The <b>DAC Configuration</b> options provide access to per channel configuration options such as power-down options and hardware LDAC mask setting.
J	Selecting enabled from the internal reference setting enables the on-chip reference for the board, if disabled is selected, an external reference must be applied. This control is only available on the <a href="#">AD5675R</a> .
K	The <b>Apply Changes</b> button applies all modified values to the device. Note that if an evaluation board is not connected, values entered into the Input Registers are not transferred to the DAC registers.

**MEMORY MAP**

All registers are fully accessible from the memory map tab, this allows the registers to be edited at a bit level. The bits shaded in dark gray are read only bits and cannot be accessed from the ACE; all other bits are toggled. **Apply Changes** is used to transfer data to the device. All changes here correspond to the block diagram, for example, if the internal register bit is enabled, it shows as enabled on the block diagram. Any bits or registers that are in bold are modified values that have not been transferred to the board. After **Apply Changes** is clicked the data is transferred to the board.



Figure 5. AD5675R Memory Map



Figure 6. AD5675R Memory Map with Unapplied Changes in DAC0 Input Register

## EVALUATION BOARD HARDWARE

### POWER SUPPLIES

To use the evaluation board with the [SDP-B](#) board, a 6 V dc power supply is required, which is connected to Connector J3. The evaluation board can be used without the [SDP-B](#) board, in which case, the J1 and J2 connectors are used as the power supply inputs.

Both AGND and DGND inputs are provided on the board. The AGND and DGND planes are connected at one location close to the [AD5675/AD5675R](#). It is recommended that AGND and DGND not be connected elsewhere in the system to avoid ground loop problems.

All supplies are decoupled to ground with 10  $\mu$ F tantalum and 0.1  $\mu$ F ceramic capacitors.

Table 2. Power Supply Connectors

Connector Number	Voltage
J1	External, $V_{LOGIC}$ supply
J2	Analog power supply, $V_{CC}$
J3	6 V dc board positive power supply

### INPUT SIGNALS

When the [SDP-B](#) board is used to control the evaluation board, the digital input signals are applied to Connector J4. When the [SDP-B](#) board is not used, apply the digital signal to Connector J5.

### OUTPUT SIGNALS

The DAC output voltages are available on the SMB connectors, VOUT0 to VOUT7.

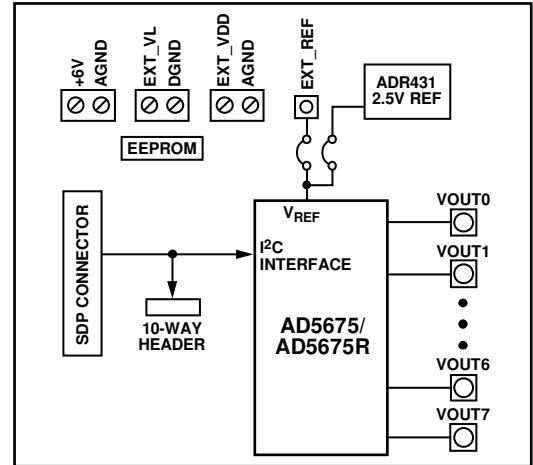

Figure 7. Evaluation Board Block Diagram

## LINK CONFIGURATION OPTIONS

Multiple link (LKx) options must be set correctly to select the appropriate operating setup before using the evaluation board. The functions of these options are described in Table 3.

### SETUP CONDITIONS

Before applying power and signals to the evaluation board, ensure that all link positions are as required by the operating mode. There are two modes in which to operate the evaluation

board. The evaluation board can be operated in SDP controlled mode to be used with the [SDP-B](#) board, or the evaluation board can be used in standalone mode.

The Default Position column of Table 3 shows the default positions in which the links are set when the evaluation board is packaged. When the boards is shipped, it is set up to operate with the [SDP-B](#) board in SDP controlled mode.

**Table 3. Link Functions**

Link No.	Function	Default Position
LK1	This link selects the DAC analog voltage source. Position A selects the internal voltage source (INT_VCC) from the <a href="#">ADP7104</a> (U3). Position B selects an external supply voltage (EXT_VCC).	A
LK2	This link selects the DAC digital voltage source. Position A selects the digital voltage source from the <a href="#">SDP-B</a> board (V_IO). Position B selects an external digital supply voltage (EXT_VLOGIC).	A
LK3	This link selects the power-on voltage for the DAC outputs. Position A selects midscale as the power-on voltage for the DAC outputs Position B selects 0 V as the power-on voltage for the DAC outputs	B
LK4	This link selects the reference source. Position A selects the internal reference of the <a href="#">AD5675R</a> as the reference source or an external reference source from the SMB connector EXT_REF. Use only Position A with the <a href="#">EVAL-AD5675RSDZ</a> . Position B selects U5, the <a href="#">ADR431</a> , as the 2.5 V reference source. Do not use Position B with the <a href="#">EVAL-AD5675RSDZ</a> .	A/B <sup>1</sup>
LK5	This link selects the gain setting of the <a href="#">AD5675/AD5675R</a> . Position A allows the SDP software to set the state of RSTSEL. Position B selects a DAC output span of 0 V to $2 \times V_{REF}$ . Position C selects a DAC output span of 0 V to $V_{REF}$ .	A

<sup>1</sup> Position A is the default for the [EVAL-AD5675RSDZ](#). Position B is the default for the [EVAL-AD5675SDZ](#).



## EVALUATION BOARD CIRCUITRY

The [EVAL-AD5675SDZ/EVAL-AD5675RSDZ](#) evaluation boards allow the function and performance of the [AD5675/AD5675R](#) to be easily tested. Each evaluation board contains two voltage regulators that generate the analog and digital power supplies and that also power the [SDP-B](#) board if it is connected. The two regulators are powered via a 6 V supply attached to Connector J3. Alternatively, a separate analog supply can be attached via Connector J2, and an external  $V_{\text{LOGIC}}$  supply can be connected to Connector J1.

Control of the [AD5675/AD5675R](#) is typically performed by the [SDP-B](#) board, which is attached to Connector J4. The [SDP-B](#) board allows the software provided with the kit to be used to load register values, set the voltage of the DAC outputs, and write to the control register of the [AD5675/AD5675R](#). When the [SDP-B](#) board is not required, the control signals can be applied to the [AD5675/AD5675R](#) by connecting them to the relevant pins on Connector J5.

The DAC output voltages are available on the SMB connectors, VOUT0 to VOUT7.

EVALUATION BOARD SCHEMATICS

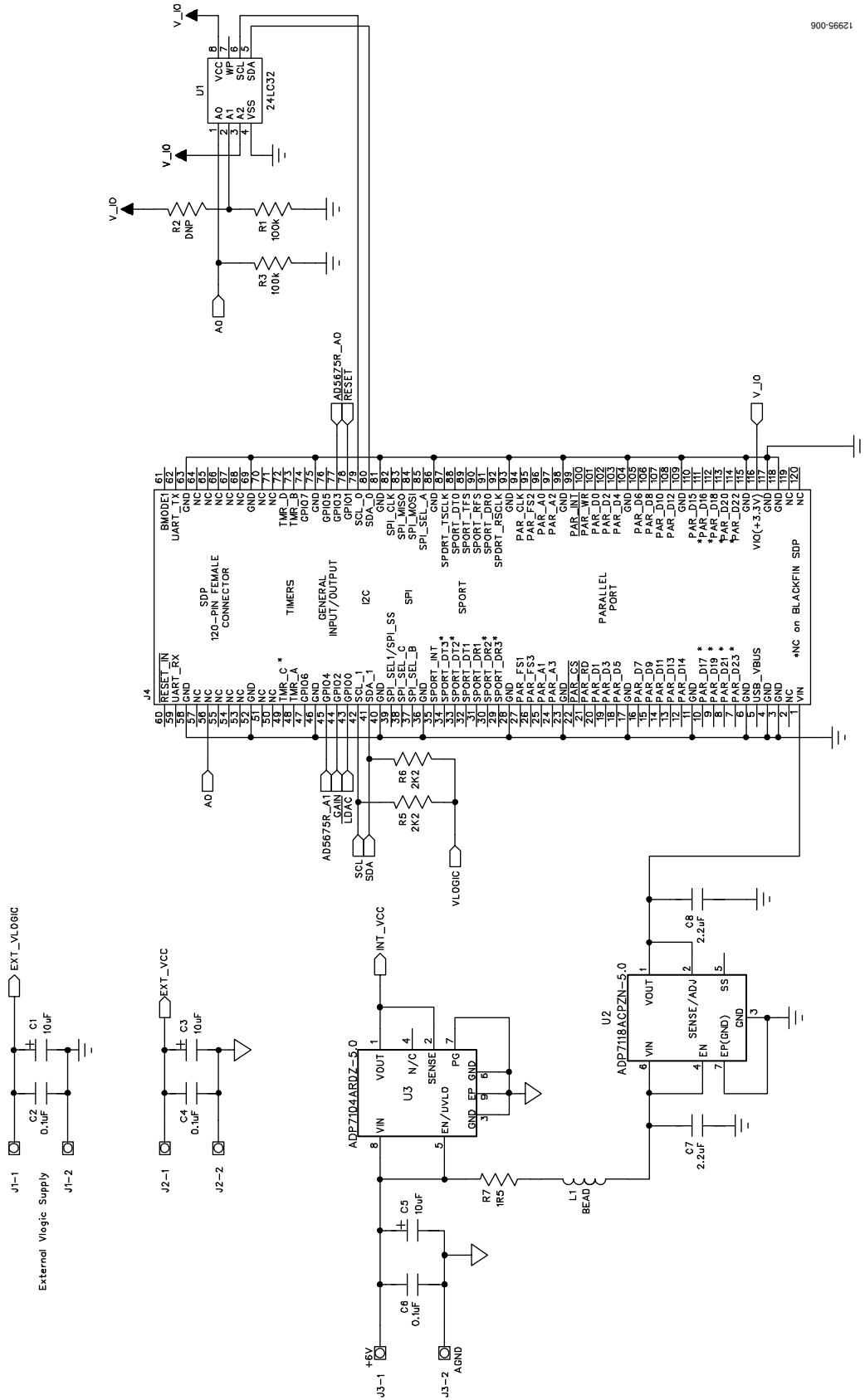

90059621

Figure 8. EVAL-AD5675SDZ/EVAL-AD5675RSDZ Schematic, Page 1 of 2

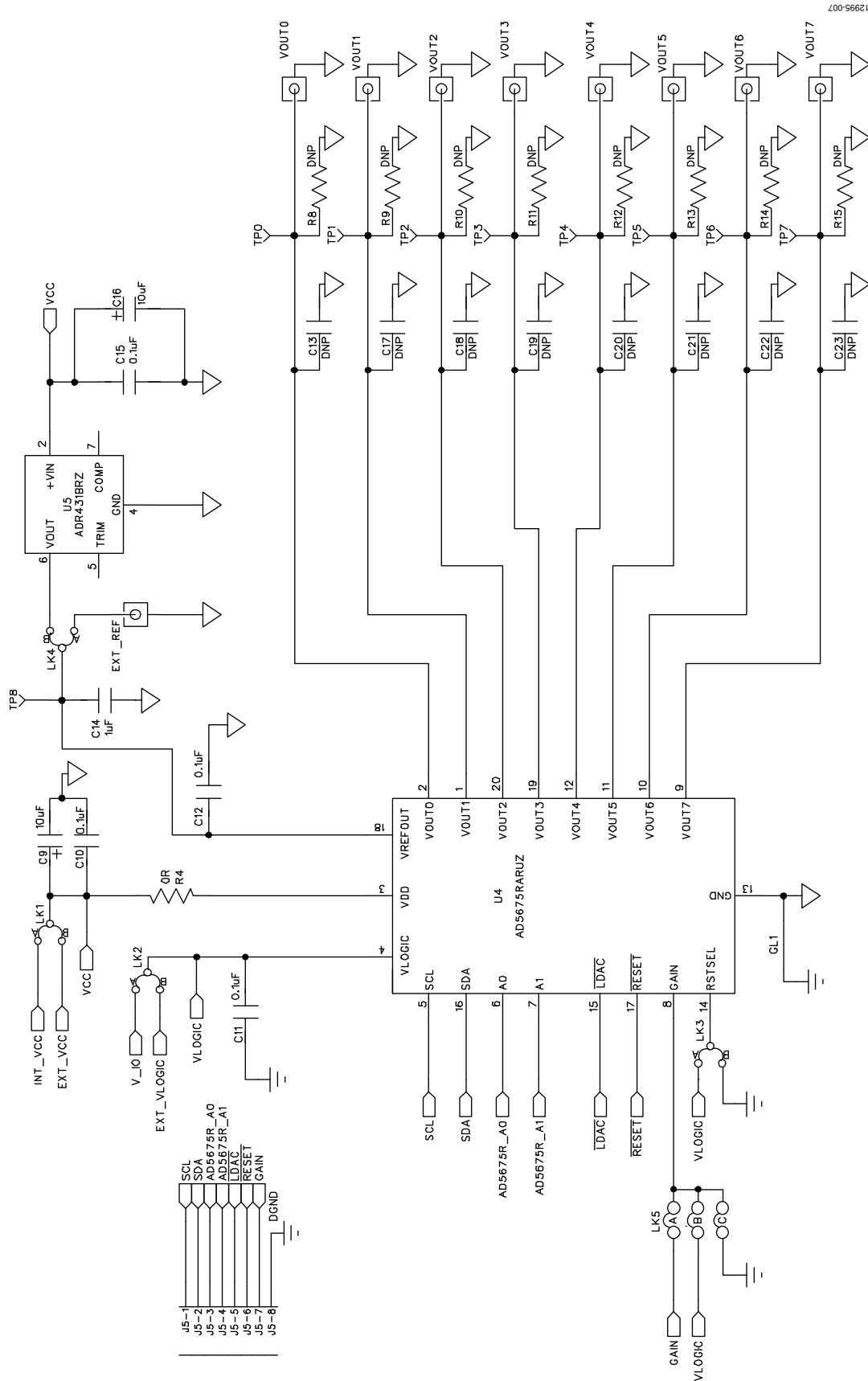

Figure 9. EVAL-AD5675SDZ/EVAL-AD5675RSDZ Schematic, Page 2 of 2

## BILL OF MATERIALS

Table 4.

Qty	Reference Designator	Description	Supplier/Part Number <sup>1</sup>
4	C1, C3, C5, C9	Capacitor, Case A, 10 $\mu$ F, 10 V	FEC 197-130
1	C16 <sup>2</sup>	Capacitor, Case A, 10 $\mu$ F, 10 V	FEC 197-130
6	C2, C4, C6, C10 to C12	Capacitor, 100 nF, 50 V, 0603	FEC 8820023
1	C15 <sup>2</sup>	Capacitor, 100 nF, 50 V, 0603	FEC 8820023
2	C7-C8	Capacitor, 2.2 $\mu$ F, 10 V, 0603	FEC 1797012
7	C13, C17 to C23	Do not insert	Do not insert
1	C14	Capacitor, 0603, 1 $\mu$ F, 10 V	FEC 318-8840
9	EXT_REF, VOUT0 to VOUT7	Straight PCB mount SMB jack, 50 $\Omega$	FEC 1206013
3	J1-J3	2-pin terminal block (5 mm pitch)	FEC 151789
1	J4	120-way female connector, 0.6 mm pitch	FEC 1324660 or Digikey H1219-ND
1	J5	8-pin (2x4), 0.1" pitch SMT header	FEC 1022244 (36-pin strip)
1	L1	Ferrite bead	Digikey 490-1024-1-ND
4	LK1-LK4	Jumper block using 3-pin SIP header (insert in Position A)	FEC 1022248 and 150410
4	R1, R3, R5, R6	SMD resistor	FEC 9330402
10	R2, R8-R15	Do not insert	Do not insert
1	R4	Resistor, 0805 0R0	FEC 9333681
1	R7	Resistor, 1R5, 5%, 0.063 W, 0603	FEC 9331832
1	R8	Do not insert	Do not insert
9	TP0-TP8	Red test point	FEC 8731144 (pack)
1	U1	32k I <sup>2</sup> C serial EEPROM	FEC 1331330
1	U2	Linear regulator, 5.0 V, ultralow noise, CMOS	<a href="#">ADP7118ACPZN-5.0-R7</a>
1	U3	Linear regulator, 5 V, 20 V, 500 mA, ultralow noise, CMOS	<a href="#">ADP7104ARDZ-5.0-R7</a>
1	U4	16-bit DAC	<a href="#">AD5675RARUZ</a> <sup>3</sup> or <a href="#">AD5675ARUZ</a> <sup>4</sup>
1	U5 <sup>2</sup>	Ultralow noise XFET voltage references	<a href="#">ADR431BRZ</a>
1	Screw1, Screw2	Screw, cheese, nylon, M3X10, PK100	FEC 7070597
2	Nut1, Nut2	Nut/washer, nylon, M3, PK100	FEC 7061857

<sup>1</sup> FEC is Farnell Electronics Components<sup>2</sup> Not populated on [EVAL-AD5675RSDZ](#)<sup>3</sup> Populated on [EVAL-AD5675RSDZ](#)<sup>4</sup> Populated on [EVAL-AD5675SDZ](#)

## NOTES

I<sup>2</sup>C refers to a communications protocol originally developed by Philips Semiconductors (now NXP Semiconductors).

**ESD Caution**

**ESD (electrostatic discharge) sensitive device.** Charged devices and circuit boards can discharge without detection. Although this product features patented or proprietary protection circuitry, damage may occur on devices subjected to high energy ESD. Therefore, proper ESD precautions should be taken to avoid performance degradation or loss of functionality.

**Legal Terms and Conditions**

By using the evaluation board discussed herein (together with any tools, components documentation or support materials, the "Evaluation Board"), you are agreeing to be bound by the terms and conditions set forth below ("Agreement") unless you have purchased the Evaluation Board, in which case the Analog Devices Standard Terms and Conditions of Sale shall govern. Do not use the Evaluation Board until you have read and agreed to the Agreement. Your use of the Evaluation Board shall signify your acceptance of the Agreement. This Agreement is made by and between you ("Customer") and Analog Devices, Inc. ("ADI"), with its principal place of business at One Technology Way, Norwood, MA 02062, USA. Subject to the terms and conditions of the Agreement, ADI hereby grants to Customer a free, limited, personal, temporary, non-exclusive, non-sublicensable, non-transferable license to use the Evaluation Board FOR EVALUATION PURPOSES ONLY. Customer understands and agrees that the Evaluation Board is provided for the sole and exclusive purpose referenced above, and agrees not to use the Evaluation Board for any other purpose. Furthermore, the license granted is expressly made subject to the following additional limitations: Customer shall not (i) rent, lease, display, sell, transfer, assign, sublicense, or distribute the Evaluation Board; and (ii) permit any Third Party to access the Evaluation Board. As used herein, the term "Third Party" includes any entity other than ADI, Customer, their employees, affiliates and in-house consultants. The Evaluation Board is NOT sold to Customer; all rights not expressly granted herein, including ownership of the Evaluation Board, are reserved by ADI. CONFIDENTIALITY. This Agreement and the Evaluation Board shall all be considered the confidential and proprietary information of ADI. Customer may not disclose or transfer any portion of the Evaluation Board to any other party for any reason. Upon discontinuation of use of the Evaluation Board or termination of this Agreement, Customer agrees to promptly return the Evaluation Board to ADI. ADDITIONAL RESTRICTIONS. Customer may not disassemble, decompile or reverse engineer chips on the Evaluation Board. Customer shall inform ADI of any occurred damages or any modifications or alterations it makes to the Evaluation Board, including but not limited to soldering or any other activity that affects the material content of the Evaluation Board. Modifications to the Evaluation Board must comply with applicable law, including but not limited to the RoHS Directive. TERMINATION. ADI may terminate this Agreement at any time upon giving written notice to Customer. Customer agrees to return to ADI the Evaluation Board at that time. LIMITATION OF LIABILITY. THE EVALUATION BOARD PROVIDED HEREUNDER IS PROVIDED "AS IS" AND ADI MAKES NO WARRANTIES OR REPRESENTATIONS OF ANY KIND WITH RESPECT TO IT. ADI SPECIFICALLY DISCLAIMS ANY REPRESENTATIONS, ENDORSEMENTS, GUARANTEES, OR WARRANTIES, EXPRESS OR IMPLIED, RELATED TO THE EVALUATION BOARD INCLUDING, BUT NOT LIMITED TO, THE IMPLIED WARRANTY OF MERCHANTABILITY, TITLE, FITNESS FOR A PARTICULAR PURPOSE OR NON-INFRINGEMENT OF INTELLECTUAL PROPERTY RIGHTS. IN NO EVENT WILL ADI AND ITS LICENSORS BE LIABLE FOR ANY INCIDENTAL, SPECIAL, INDIRECT, OR CONSEQUENTIAL DAMAGES RESULTING FROM CUSTOMER'S POSSESSION OR USE OF THE EVALUATION BOARD, INCLUDING BUT NOT LIMITED TO LOST PROFITS, DELAY COSTS, LABOR COSTS OR LOSS OF GOODWILL. ADI'S TOTAL LIABILITY FROM ANY AND ALL CAUSES SHALL BE LIMITED TO THE AMOUNT OF ONE HUNDRED US DOLLARS (\$100.00). EXPORT. Customer agrees that it will not directly or indirectly export the Evaluation Board to another country, and that it will comply with all applicable United States federal laws and regulations relating to exports. GOVERNING LAW. This Agreement shall be governed by and construed in accordance with the substantive laws of the Commonwealth of Massachusetts (excluding conflict of law rules). Any legal action regarding this Agreement will be heard in the state or federal courts having jurisdiction in Suffolk County, Massachusetts, and Customer hereby submits to the personal jurisdiction and venue of such courts. The United Nations Convention on Contracts for the International Sale of Goods shall not apply to this Agreement and is expressly disclaimed.