

DO NOT SCALE FROM THIS PRINT

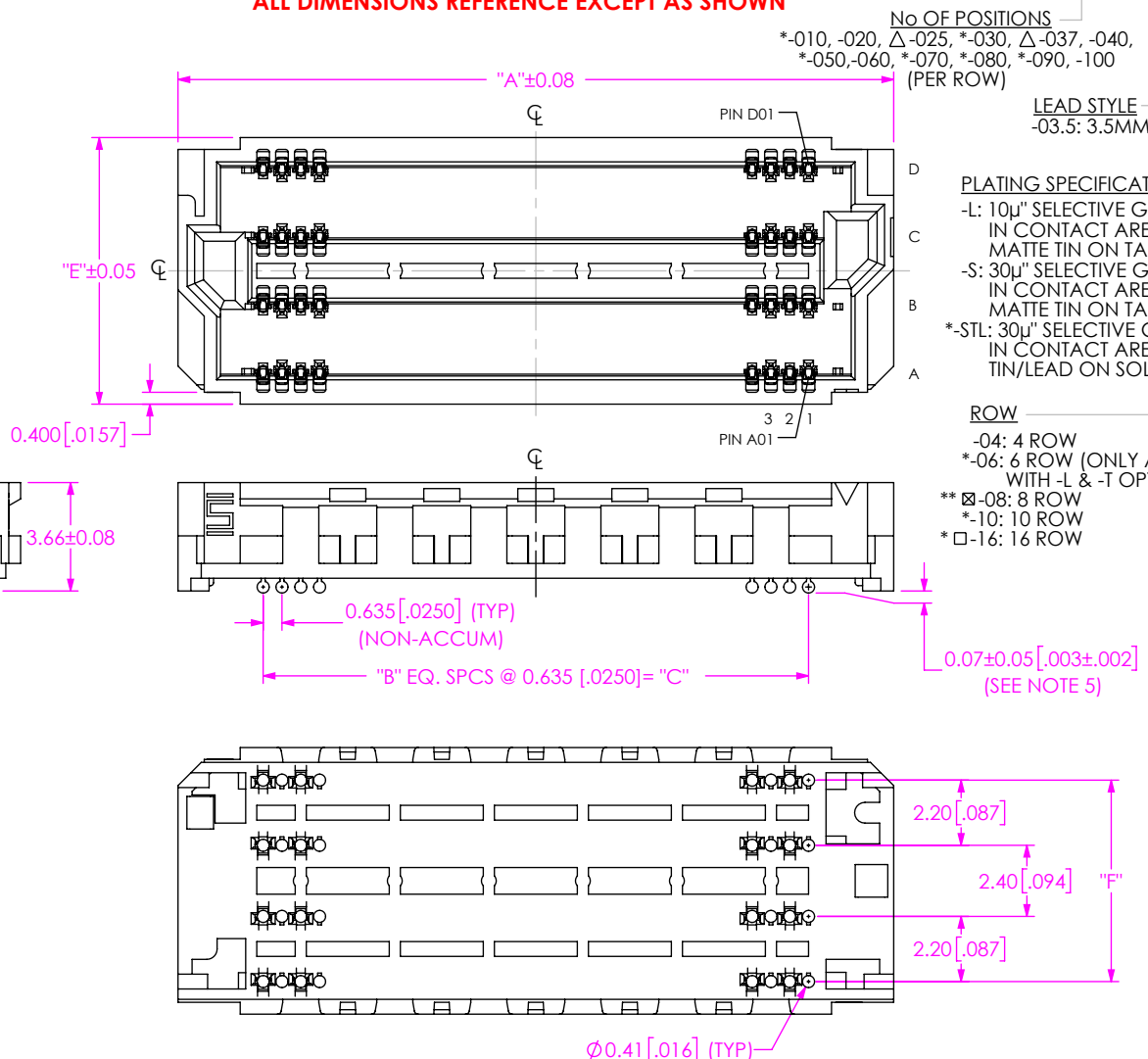

No OF POSITIONS  
\*-010, -020, Δ-025, \*-030, Δ-037, -040, \*-050, -060, \*-070, \*-080, \*-090, -100 (PER ROW)

LEAD STYLE  
-03.5: 3.5MM

PLATING SPECIFICATION  
-L: 10μ" SELECTIVE GOLD IN CONTACT AREA, MATTE TIN ON TAIL  
-S: 30μ" SELECTIVE GOLD IN CONTACT AREA, MATTE TIN ON TAIL  
\*-STL: 30μ" SELECTIVE GOLD IN CONTACT AREA, TIN/LEAD ON SOLDER TAIL.

ROW  
-04: 4 ROW  
\*-06: 6 ROW (ONLY AVAILABLE WITH -L & -T OPTIONS)  
\*\* ⊠-08: 8 ROW  
\*-10: 10 ROW  
\* □-16: 16 ROW

TAPE & REEL (SEE NOTES 3 & 7)  
-TR: TAPE & REEL  
-FR: FULL QTY TAPE AND REEL

OPTION  
BLANK: NO ALIGNMENT PIN  
-A: ALIGNMENT PIN (SEE SHT 5, FIG 3)  
-L: SQUEEZE LATCH (SEE SHT 3, FIG 5, NOT AVAILABLE WITH -A OPTION, ONLY AVAILABLE IN -025 & -037 POS WITH -04 & -06 ROW)  
\*\* -T: TH LOCKING TOOL (SEE SHT 3, FIG 6, NOT AVAILABLE WITH -A OPTION, ONLY AVAILABLE IN -025 & -037 POS WITH -04, -06 & -08 ROW)  
\*\* -TS: SM LOCKING TOOL (SEE SHT 4, FIG 7, NOT AVAILABLE WITH -A OPTION, ONLY AVAILABLE IN -025 & -037 POS WITH -08 ROW)

SOLDERBALL COMPOSITION  
\*\* -0: NO SOLDER BALL  
\* -1: 63.0% TIN/37.0% LEAD  
-2: 95.5% TIN/3.8% SILVER/0.7% COPPER

(\* = NOT TOOLED)  
(PACKAGING: TAPE & REEL, SEE NOTES 1, 2 & 3)  
□ = ONLY AVAILABLE IN -50 POS)  
⊠ = ONLY AVAILABLE IN -025, -037 & -100 POS)  
Δ = ONLY AVAILABLE IN -L, -T & -TS OPTION)  
(\*\* = NOT RELEASED)

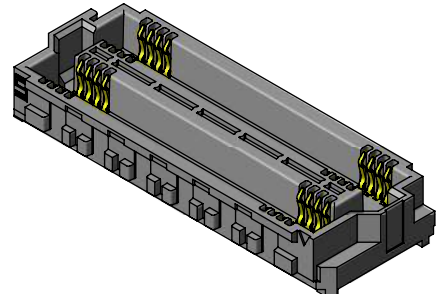

No. OF ROWS	"E"	"F"
-04	9.00 [0.354]	6.80 [0.268]
-06	13.60 [0.535]	11.40 [0.449]
-08	18.20 [0.717]	16.00 [0.630]
-10	22.80 [0.898]	20.60 [0.811]
-16	36.60 [1.441]	34.40 [1.354]

APF6 LEAD STYLE	APM6 LEAD STYLE	
	-01.5	-06.5
-03.5	5.00 [0.197]	10.00 [0.394]

No OF POS PER ROW	"A"	"B"	"C"
-010	11.47 [0.451]	9	5.72 [0.225]
-020	17.82 [0.701]	19	12.07 [0.475]
-030	24.17 [0.951]	29	18.42 [0.725]
-040	30.52 [1.201]	39	24.77 [0.975]
-050	36.87 [1.451]	49	31.12 [1.225]
-060	43.22 [1.701]	59	37.47 [1.475]
-070	49.57 [1.951]	69	43.82 [1.725]
-080	55.92 [2.201]	79	50.17 [1.975]
-090	62.27 [2.451]	89	56.52 [2.225]
-100	68.62 [2.701]	99	62.87 [2.475]

FIG 1  
APF6-030-03.5-XXX-04-X SHOWN  
(SOME CENTER FEATURES REMOVED FOR CLARITY)

- NOTES:
1. TAPE & REEL IS STANDARD PACKAGING.
  2. NOTE DELETED.
  3. ATTACH LABEL-4X2 TO EACH TAPE & REEL PACKAGE.
  4. K-DOT PROVIDED AS STANDARD.
  5. MEASURE BOTH OUTSIDE ROWS ONLY.
  6. SEE SHEET 3 FOR PROCESSING INFORMATION.
  7. ORDERS WILL BE PACKAGED ACCORDING TO THE SAMTEC PACKAGING EFFICIENCY STANDARDS (SPES) FOUND ON WWW.SAMTEC.COM

PROPRIETARY NOTE  
THIS DOCUMENT CONTAINS CONFIDENTIAL AND PROPRIETARY INFORMATION AND ALL DESIGN, MANUFACTURING, REPRODUCTION, USE, PATENT RIGHTS AND SALES RIGHTS ARE EXPRESSLY RESERVED BY SAMTEC, INC. THIS DOCUMENT SHALL NOT BE DISCLOSED, IN WHOLE OR PART, TO ANY UNAUTHORIZED PERSON OR ENTITY NOR REPRODUCED, TRANSFERRED OR INCORPORATED IN ANY OTHER PROJECT IN ANY MANNER WITHOUT THE EXPRESS WRITTEN CONSENT OF SAMTEC, INC.

DO NOT SCALE DRAWING  
SHEET SCALE: 4:1  
MATERIAL: INSULATOR: LCP, UL 94 V-0; COLOR: BLACK CONTACT: COPPER ALLOY

520 PARK EAST BLVD, NEW ALBANY, IN 47150  
PHONE: 812-944-6733 FAX: 812-948-5047  
e-Mail: info@SAMTEC.com code 53322

DESCRIPTION:  
APF6 0.635MM SOCKET ARRAY ASSEMBLY

DWG. NO.  
APF6-XXX-XX.X-XXX-XX-X-XX-XR

BY: B BLESSING 5/26/2018 SHEET 1 OF 6

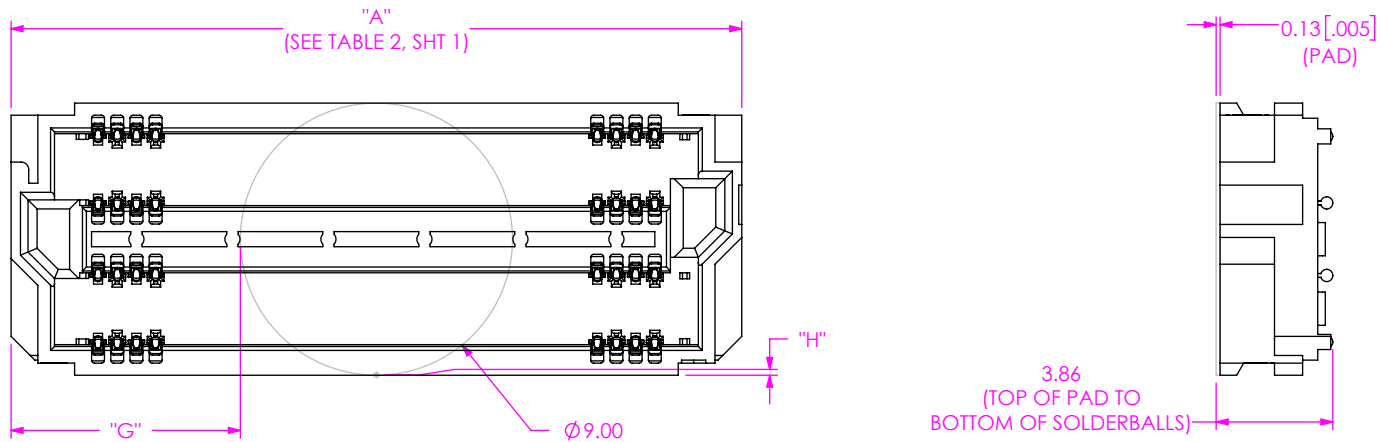

FIG 2  
 POLYIMIDE PAD  
 APF6-030-03.5-XXX-04-X SHOWN  
 (SOME CENTER FEATURES REMOVED FOR CLARITY)

-No. OF ROWS	-010	-020	-025	-030	-037	-040	-050	-060	-070	-080	-090	-100	"H"
-04													0.00 [0.000]
-06													2.30 [0.091]
-08	1.23 [0.049]	4.41 [0.174]	6.70 [0.264]	7.58 [0.299]	10.51 [0.414]	10.76 [0.424]	13.93 [0.549]	17.11 [0.674]	20.28 [0.799]	23.46 [0.924]	26.63 [1.049]	29.81 [1.174]	4.60 [0.181]
-10													6.90 [0.272]
-16													13.80 [0.543]

**PROPRIETARY NOTE**  
 THIS DOCUMENT CONTAINS CONFIDENTIAL AND PROPRIETARY INFORMATION AND ALL DESIGN, MANUFACTURING, REPRODUCTION, USE, PATENT RIGHTS AND SALES RIGHTS ARE EXPRESSLY RESERVED BY SAMTEC, INC. THIS DOCUMENT SHALL NOT BE DISCLOSED, IN WHOLE OR PART, TO ANY UNAUTHORIZED PERSON OR ENTITY NOR REPRODUCED, TRANSFERRED OR INCORPORATED IN ANY OTHER PROJECT IN ANY MANNER WITHOUT THE EXPRESS WRITTEN CONSENT OF SAMTEC, INC.

**samtec**  
 520 PARK EAST BLVD, NEW ALBANY, IN 47150  
 PHONE: 812-944-6733 FAX: 812-948-5047  
 e-Mail info@SAMTEC.com code 55322

DO NOT SCALE DRAWING  
 SHEET SCALE: 4:1

DESCRIPTION:  
 APF6 0.635MM SOCKET ARRAY ASSEMBLY  
 DWG. NO.  
**APF6-XXX-XX.X-XXX-XX-X-XX-XR**  
 BY: B BLESSING 5/26/2018 SHEET 2 OF 6

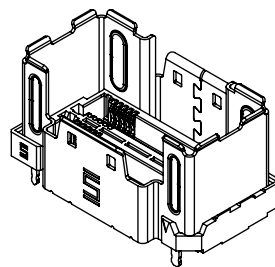
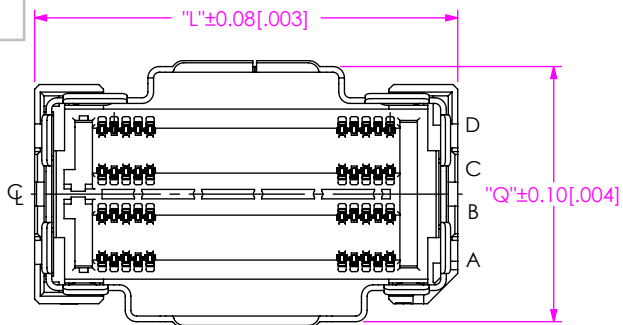

No OF POS	"L"	"M"	"N"	"P"	"U"
-025	22.39 [.881]	24	15.24 [.600]	17.59 [.693]	21.18 [.834]
-037	30.01 [1.181]	36	22.86 [.900]	25.21 [.993]	28.80 [1.134]

-No. OF ROWS	"Q"	"R"	"S"
-04	13.50 [.531]	9.90 [.390]	11.60 [.457]
-06	18.10 [.713]	14.50 [.571]	16.20 [.638]
-08 (AVAILABLE FOR -T OPTION ONLY)	N/A	19.10 [.752]	20.80 [.819]

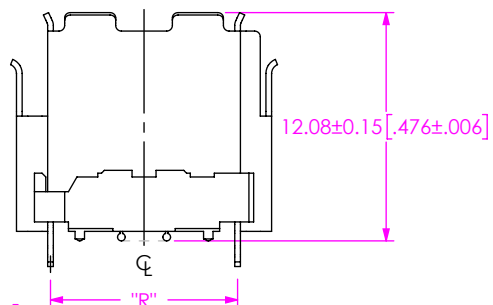
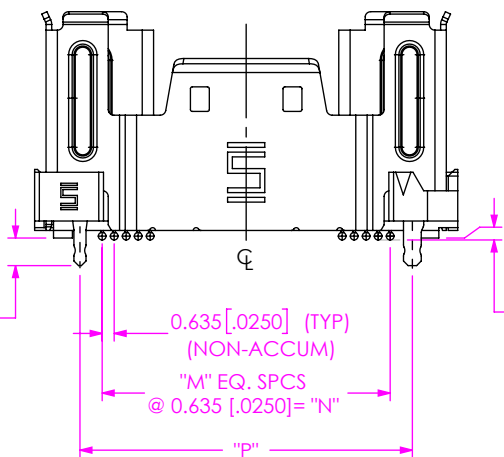

FIG 5  
-L: SQUEEZE LATCH  
APF6-025-03.5-XXX-04-X-L SHOWN  
(SAME AS FIG 1, EXCEPT AS SHOWN)  
(SOME CENTER FEATURES REMOVED FOR CLARITY)

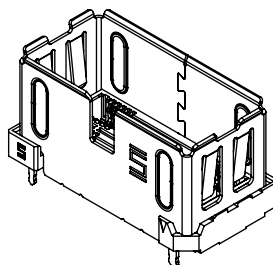
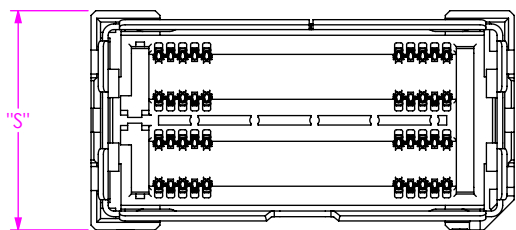
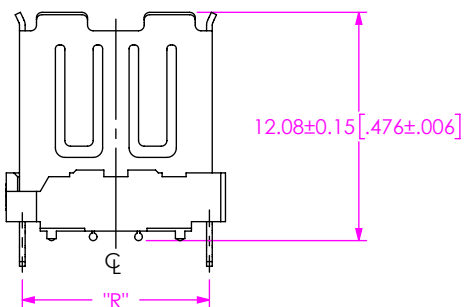
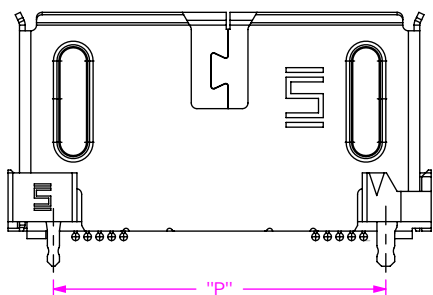

FIG 6  
-T: LOCKING TOOL  
APF6-025-03.5-XXX-04-X-T SHOWN  
(SAME AS FIG 1 & FIG5, EXCEPT AS SHOWN)  
(SOME CENTER FEATURES REMOVED FOR CLARITY)



**PROPRIETARY NOTE**  
THIS DOCUMENT CONTAINS CONFIDENTIAL AND PROPRIETARY INFORMATION AND ALL DESIGN, MANUFACTURING, REPRODUCTION, USE, PATENT RIGHTS AND SALES RIGHTS ARE EXPRESSLY RESERVED BY SAMTEC, INC. THIS DOCUMENT SHALL NOT BE DISCLOSED, IN WHOLE OR PART, TO ANY UNAUTHORIZED PERSON OR ENTITY NOR REPRODUCED, TRANSFERRED OR INCORPORATED IN ANY OTHER PROJECT IN ANY MANNER WITHOUT THE EXPRESS WRITTEN CONSENT OF SAMTEC, INC.



520 PARK EAST BLVD., NEW ALBANY, IN 47150  
PHONE: 812-944-6733 FAX: 812-948-5047  
e-Mail: info@SAMTEC.com code 5332

SHEET SCALE: 5:2

DESCRIPTION:  
APF6 0.635MM SOCKET ARRAY ASSEMBLY

DWG. NO.  
APF6-XXX-XX.X-XXX-XX-X-XX-XR

BY: B BLESSING 5/26/2018 SHEET 3 OF 6

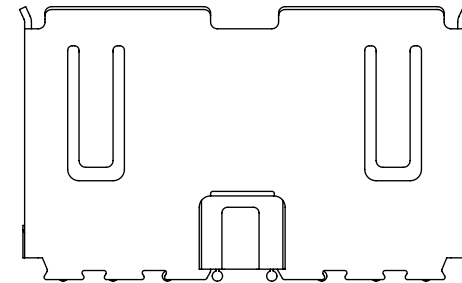
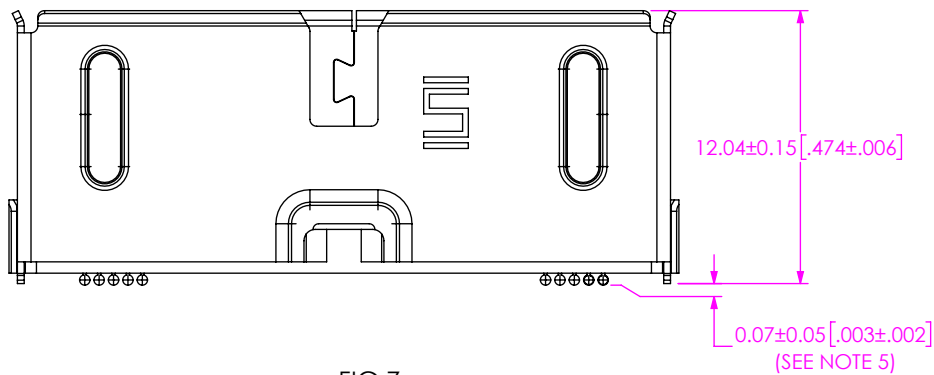
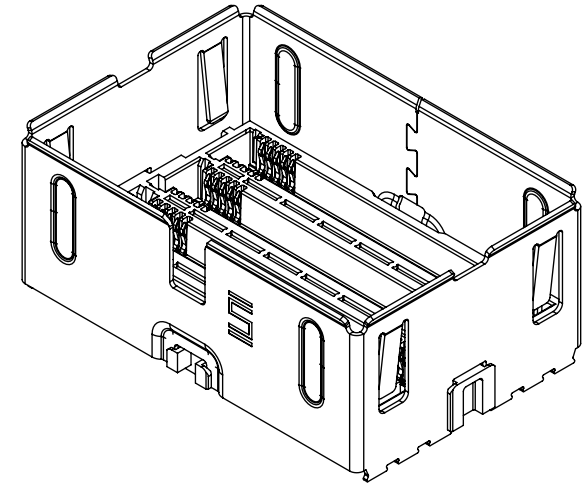
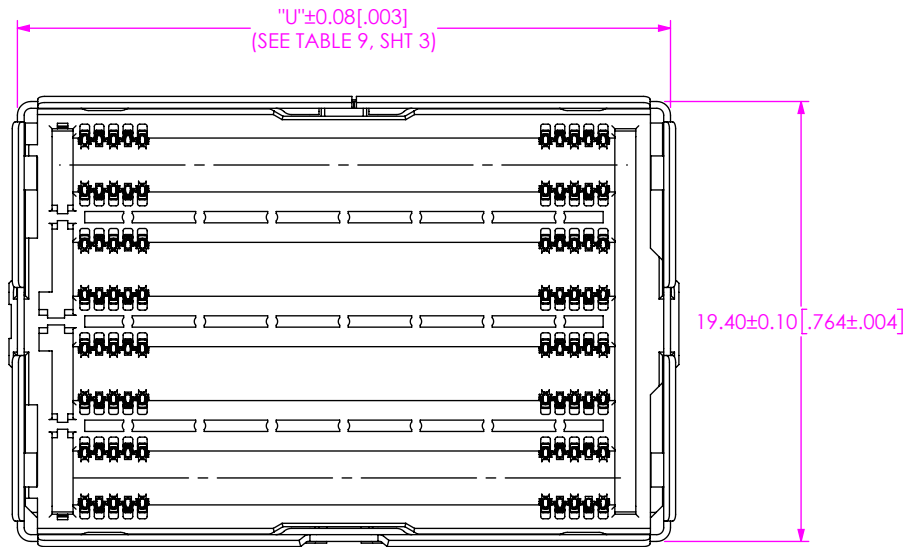

FIG 7  
 -TS: SM LOCKING TOOL  
 APF6-037-03.5-XXX-08-X-TS SHOWN  
 (SAME AS FIG 1 & FIG 5, EXCEPT AS SHOWN)  
 (SOME CENTER FEATURES REMOVED FOR CLARITY)

<p>PROPRIETARY NOTE</p> <p>THIS DOCUMENT CONTAINS CONFIDENTIAL AND PROPRIETARY INFORMATION AND ALL DESIGN, MANUFACTURING, REPRODUCTION, USE, PATENT RIGHTS AND SALES RIGHTS ARE EXPRESSLY RESERVED BY SAMTEC, INC. THIS DOCUMENT SHALL NOT BE DISCLOSED, IN WHOLE OR PART, TO ANY UNAUTHORIZED PERSON OR ENTITY NOR REPRODUCED, TRANSFERRED OR INCORPORATED IN ANY OTHER PROJECT IN ANY MANNER WITHOUT THE EXPRESS WRITTEN CONSENT OF SAMTEC, INC.</p>	<p>520 PARK EAST BLVD. NEW ALBANY, IN 47150          PHONE: 812-944-6733 FAX: 812-948-5047          e-Mail info@SAMTEC.com code 55322</p>	
	<p>DESCRIPTION:          APF6 0.635MM SOCKET ARRAY ASSEMBLY</p>	
	<p>DWG. NO.          APF6-XXX-XX.X-XXX-XX-X-XX-XR</p>	<p>BY: B BLESSING 5/26/2018 SHEET 4 OF 6</p>

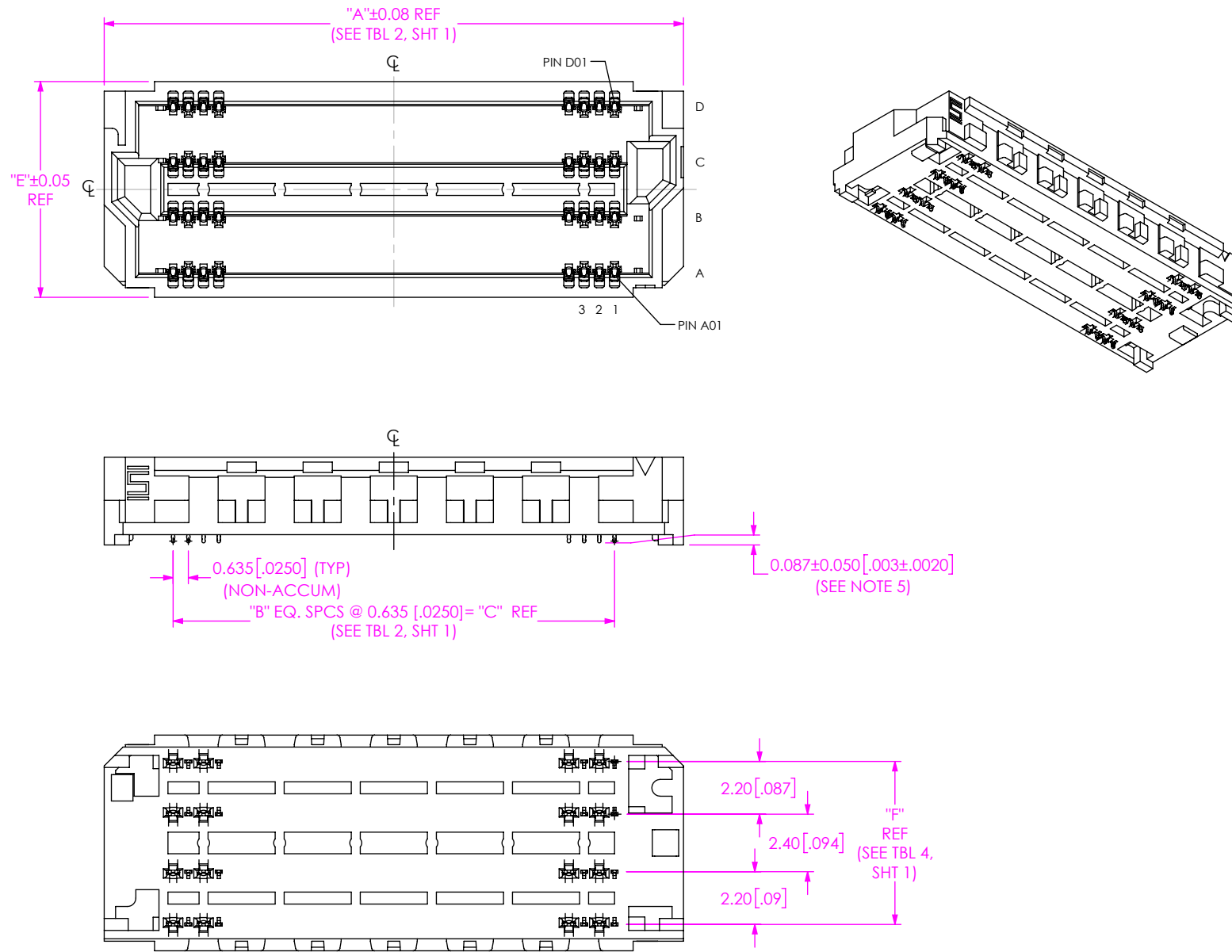

FIG 8  
 APF6-030-03.5-XXX-04-0 SHOWN  
 (NO SOLDER BALL OPTION)  
 (SOME CENTER FEATURES REMOVED FOR CLARITY)

**PROPRIETARY NOTE**  
 THIS DOCUMENT CONTAINS CONFIDENTIAL AND PROPRIETARY INFORMATION AND ALL DESIGN, MANUFACTURING, REPRODUCTION, USE, PATENT RIGHTS AND SALES RIGHTS ARE EXPRESSLY RESERVED BY SAMTEC, INC. THIS DOCUMENT SHALL NOT BE DISCLOSED, IN WHOLE OR PART, TO ANY UNAUTHORIZED PERSON OR ENTITY NOR REPRODUCED, TRANSFERRED OR INCORPORATED IN ANY OTHER PROJECT IN ANY MANNER WITHOUT THE EXPRESS WRITTEN CONSENT OF SAMTEC, INC.



520 PARK EAST BLVD, NEW ALBANY, IN 47150  
 PHONE: 812-944-6733 FAX: 812-948-5047  
 e-Mail info@SAMTEC.com code 55322

DO NOT SCALE DRAWING

SHEET SCALE: 4:1

DESCRIPTION:  
 APF6 0.635MM SOCKET ARRAY ASSEMBLY

DWG. NO.  
 APF6-XXX-XX.X-XXX-XX-X-XX-XR

BY: B BLESSING 5/26/2018 SHEET 5 OF 6

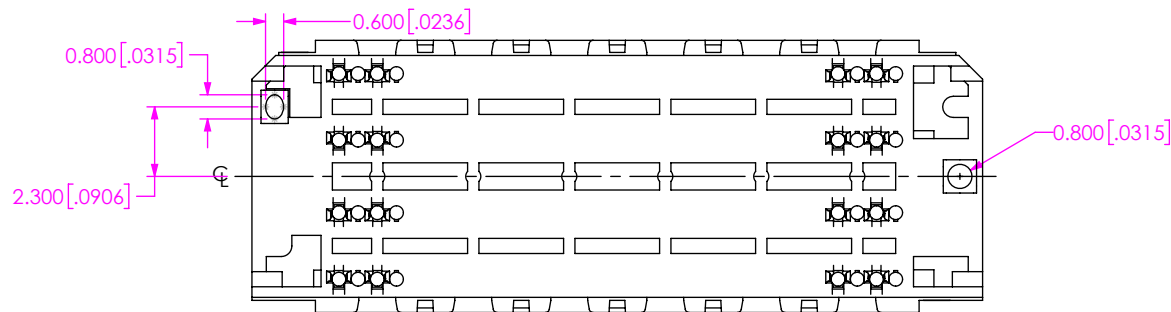
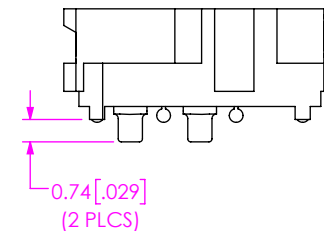
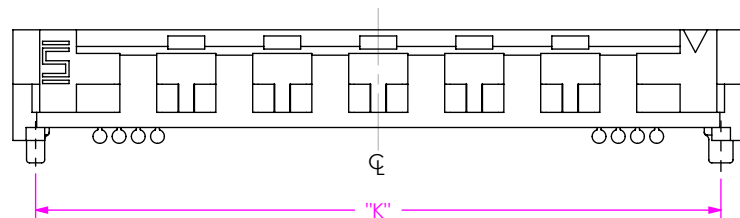

FIG 3  
 -A: ALIGNMENT PIN  
 APF6-030-03.5-XXX-04-X-A SHOWN  
 (SAME AS FIG 1, EXCEPT AS SHOWN)  
 (SOME CENTER FEATURES REMOVED FOR CLARITY)

No OF POS PER ROW	"K"
-010	9.97 [0.392]
-020	16.32 [0.642]
-030	22.67 [0.892]
-040	29.02 [1.142]
-050	35.37 [1.392]
-060	41.72 [1.642]
-070	48.07 [1.892]
-080	54.42 [2.142]
-090	60.77 [2.392]
-100	67.12 [2.642]

PART NUMBER	POSITIONS	ROW
CAT-APF6-100-04-VT	-100	-04
CAT-APF6-100-08-VT	-100	-08

CAT-APF6-XXX-XX-VT  
 PROCESSING FIXTURE  
 (SEE TABLE 8)

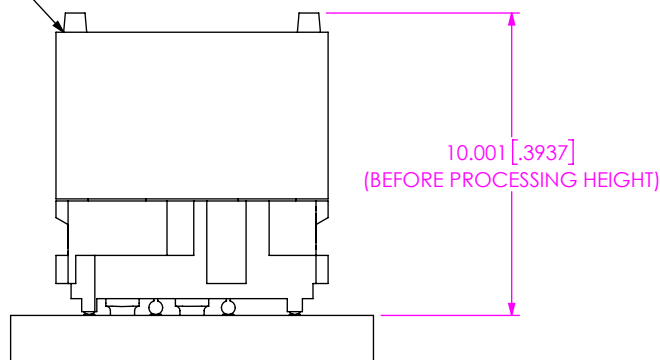

FIG 4  
 APF6-100-03.5-XXX-XX-X PROCESSING VIEW  
 (CAT-APF6-XXX-XX-VT)

NOTE:  
 FIG 4 DIMENSION 10.001 (TOP OF PCB TO TOP OF PROCESSING FIXTURE) INDICATES CONNECTOR/FIXTURE HEIGHT ON PCB TO GUARANTEE ENOUGH REFLOW OVEN WORKING SPACE, DIMENSION 10.001, PCB THICKNESS AND THE HEIGHT OF THE COMPONENTS ON THE OTHER SIDE OF THE BOARD NEED TO BE CONSIDERED.

**PROPRIETARY NOTE**  
 THIS DOCUMENT CONTAINS CONFIDENTIAL AND PROPRIETARY INFORMATION AND ALL DESIGN, MANUFACTURING, REPRODUCTION, USE, PATENT RIGHTS AND SALES RIGHTS ARE EXPRESSLY RESERVED BY SAMTEC, INC. THIS DOCUMENT SHALL NOT BE DISCLOSED, IN WHOLE OR PART, TO ANY UNAUTHORIZED PERSON OR ENTITY NOR REPRODUCED, TRANSFERRED OR INCORPORATED IN ANY OTHER PROJECT IN ANY MANNER WITHOUT THE EXPRESS WRITTEN CONSENT OF SAMTEC, INC.



520 PARK EAST BLVD, NEW ALBANY, IN 47150  
 PHONE: 812-944-6733 FAX: 812-948-5047  
 e-Mail info@SAMTEC.com code 55322

DO NOT SCALE DRAWING

SHEET SCALE: 4:1

DESCRIPTION:  
 APF6 0.635MM SOCKET ARRAY ASSEMBLY

DWG. NO.  
**APF6-XXX-XX.X-XXX-XX-X-XX-XR**

BY: B BLESSING 5/26/2018 SHEET 6 OF 6