

| PART NUMBER | DIMENSION "L" |
|-------------|---------------|
| 203263-8034 | 18.65 |
| 203263-8134 | 25.65 |
| 203263-8234 | 21.05 |
| 203263-8334 | 31.05 |
| 203263-8434 | 29.55 |
| 203263-8534 | 23.90 |
| 203263-8634 | 16.00 |
| 203263-8734 | 20.00 |
| 203263-8834 | 26.00 |
| 203263-8934 | 36.00 |
| 203263-9034 | 48.00 |

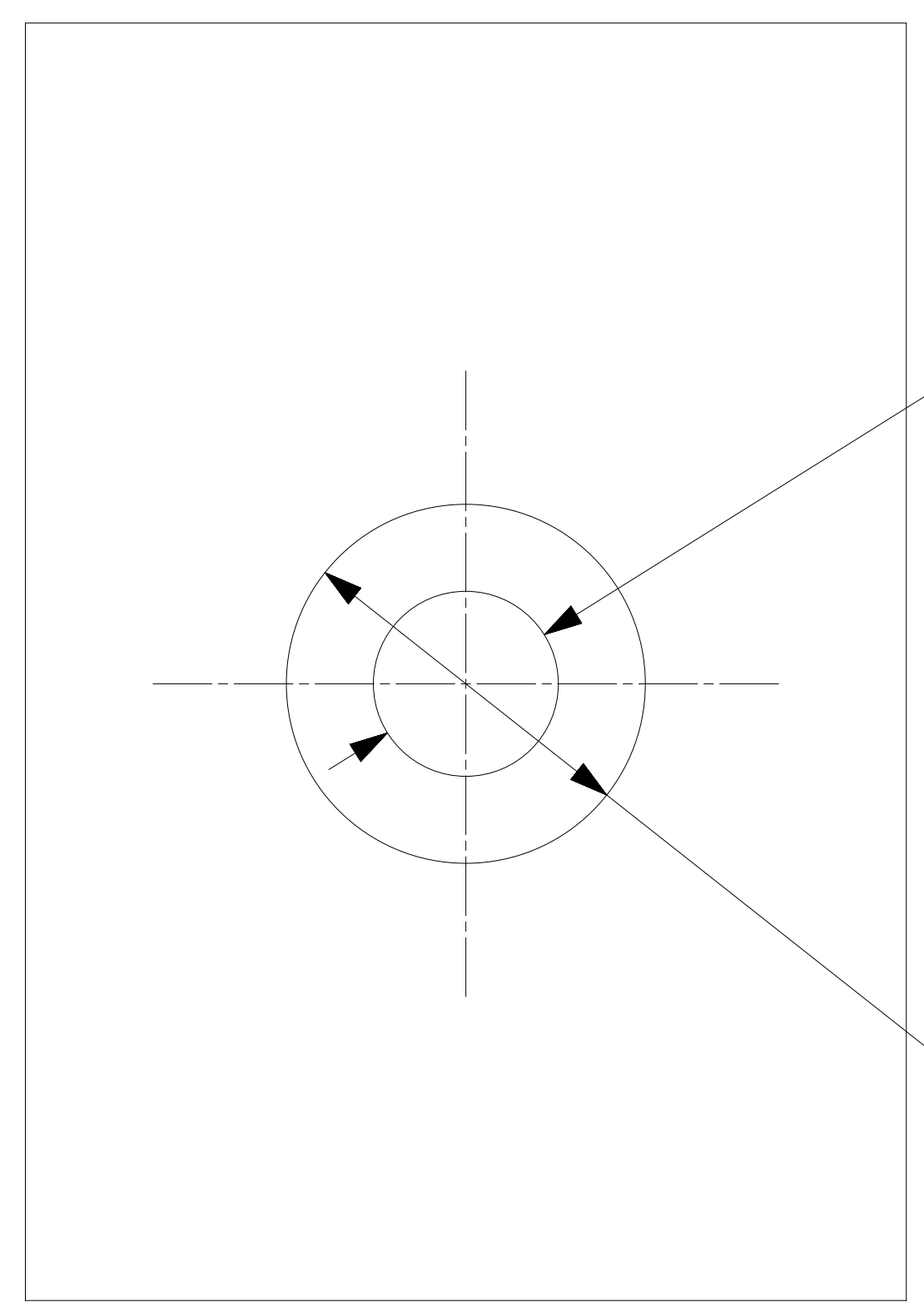

Ø4.20 ±0.05 PTH
SUGGESTED DRILL HOLE SIZE: Ø4.40MM

Ø8.15 PAD (2X)
TOP AND BOTTOM OF BOARD

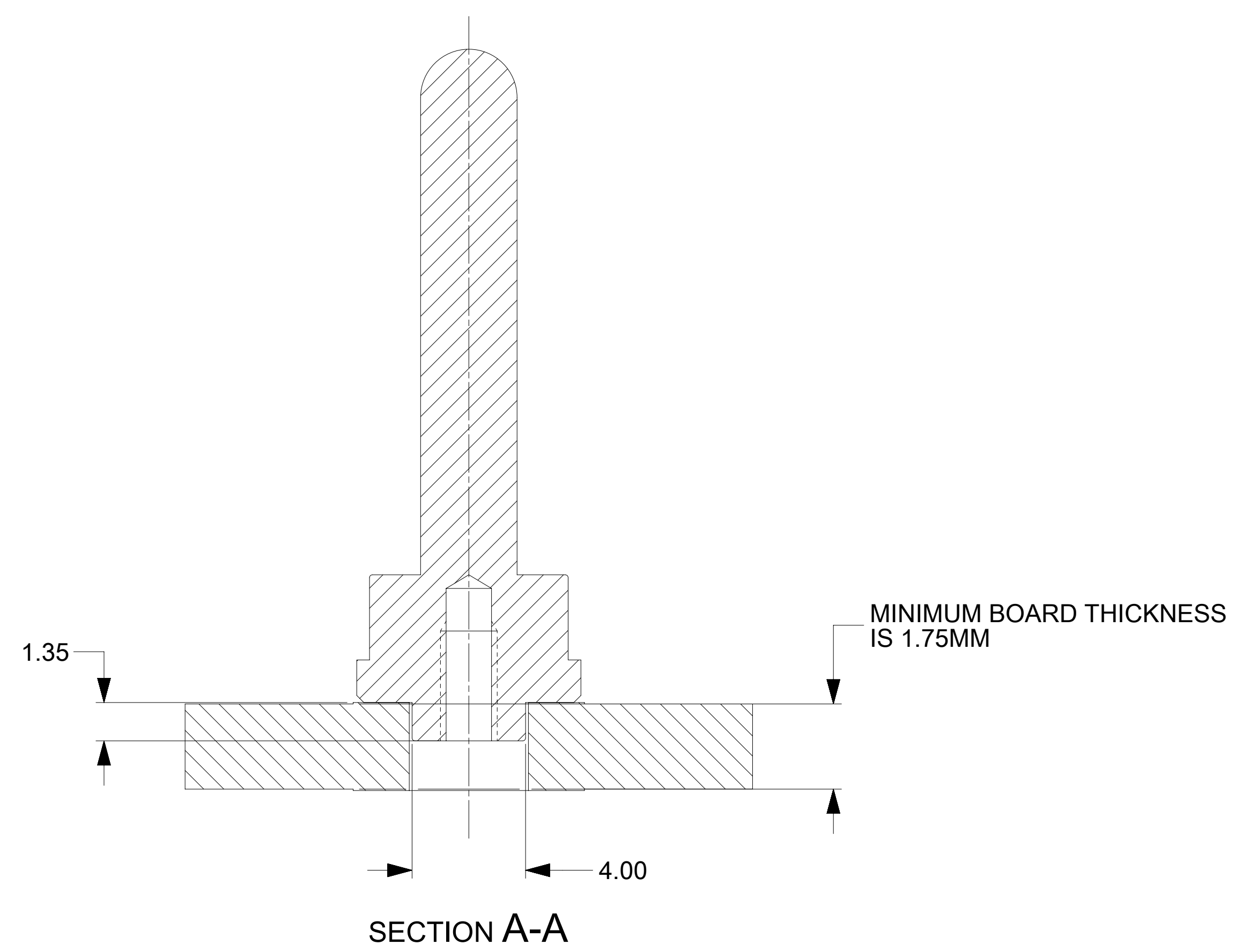
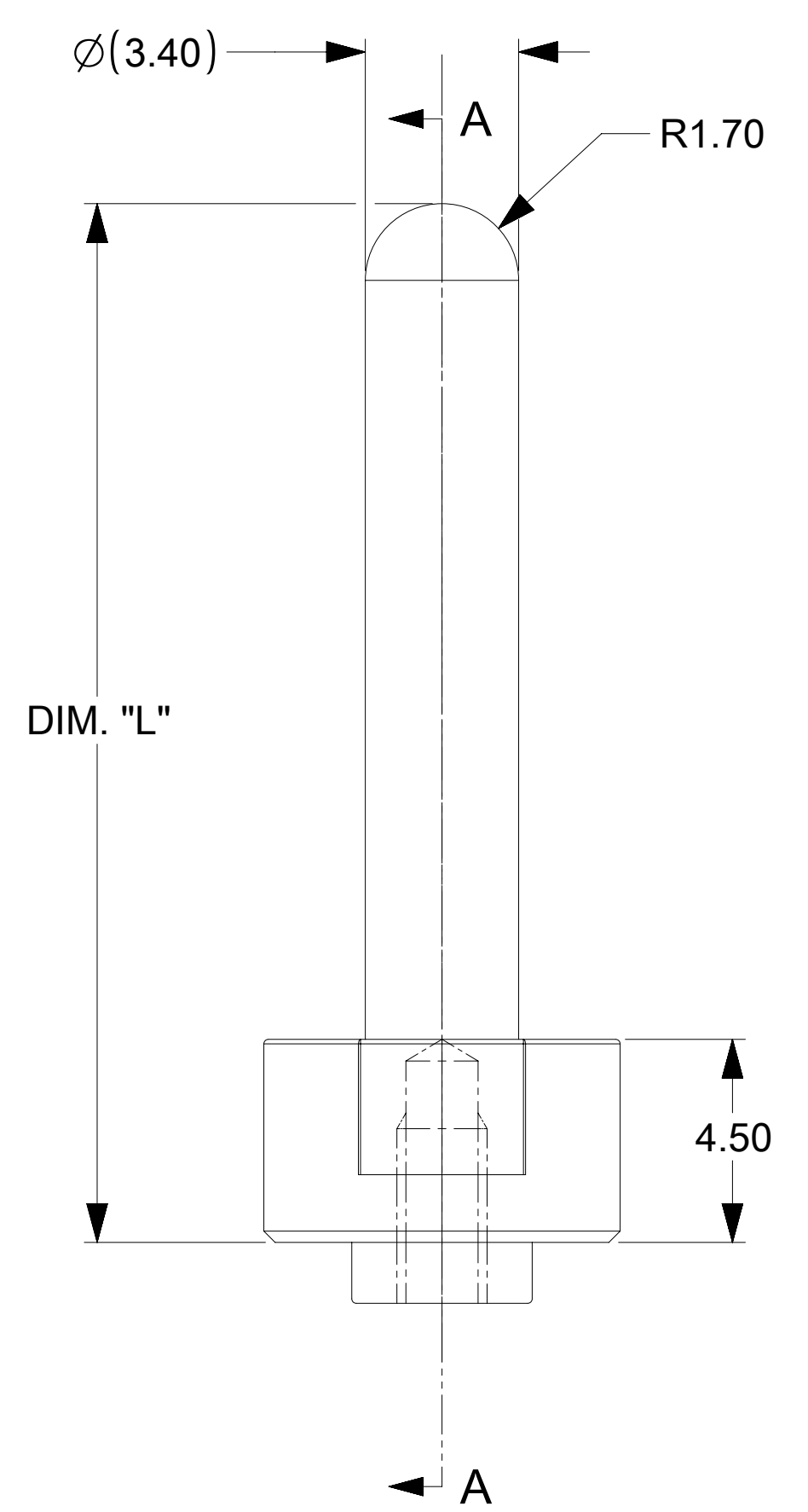
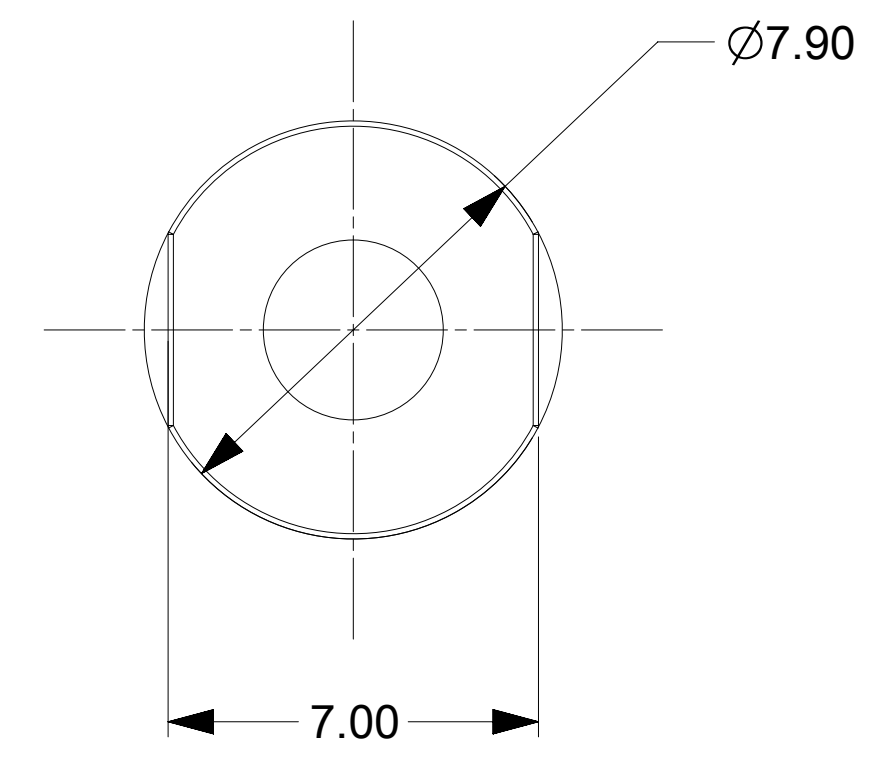

NOTES:

- MATERIALS:
 - BASE METAL: HIGH CONDUCTIVE COPPER ALLOY
 - PLATING ON BODY: 3.18 MICRON MIN SILVER OVER 1.27 MICRON MIN NICKEL
- PRODUCT SPECIFICATION : 2043130018-PS
- APPLICATION SPECIFICATION : 2043130018-AS
- PACKAGING SPECIFICATION : 2032630018-PK
- SILVER COMPONENTS WILL BE SUPPLIED TARNISH FREE BUT MAY TARNISH OVER TIME.
- PART MOUNTED WITH CONDUCTIVE M2 SCREW AND CONDUCTIVE BELLEVILLE WASHER FOR OPTIMAL PERFORMANCE
- SCREW LENGTH TO BE DETERMINED BY CUSTOMER, SCREWS AND WASHERS ARE NOT SUPPLIED BY MOLEX.

| | | | | | | | | | | | |
|---|--|-------|--|--|--|------------------------|--|-----------------|--|--------------|--|
| THIS DRAWING CONTAINS INFORMATION THAT IS PROPRIETARY TO MOLEX ELECTRONIC TECHNOLOGIES, LLC AND SHOULD NOT BE USED WITHOUT WRITTEN PERMISSION | | | | | | | | | | | |
| DIMENSION UNITS | | SCALE | | CURRENT REV DESC: UPDATED THE DESCRIPTION | | | | | | molex | |
| mm | | 1:1 | | | | | | | | | |
| GENERAL TOLERANCES (UNLESS SPECIFIED) | | | | EC NO: 726284 DRWN: SOURAJ 2022/10/26 CHK'D: SUVARS 2022/10/27 APPR: GSHARMA 2022/10/28 INITIAL REVISION: DRWN: RLOW 2019/08/14 APPR: BPISZCZOR 2019/09/04 | | | | | | | |
| ANGULAR TOL ± 0.5° | | | | | | | | | | | |
| 4 PLACES ± | | | | | | | | | | | |
| 3 PLACES ± | | | | | | | | | | | |
| 2 PLACES ± 0.15 | | | | | | | | | | | |
| 1 PLACE ± 0.25 | | | | | | | | | | | |
| 0 PLACES ± | | | | DRAFT WHERE APPLICABLE MUST REMAIN WITHIN DIMENSIONS | | THIRD ANGLE PROJECTION | | DRAWING | | SERIES | |
| | | | | D-SIZE | | 203263 | | MATERIAL NUMBER | | CUSTOMER | |
| | | | | SEE TABLE | | GENERAL MARKET | | DOCUMENT NUMBER | | REVISION | |
| | | | | | | | | 2032638034-SD | | A5 | |
| | | | | | | | | PSD | | 000 | |
| | | | | | | | | | | 1 OF 1 | |