

MARKETING SALES DRAWING
DIMENSIONS IN INCHES - DO NOT SCALE THIS DRAWING

Electrical Testing
 per Tusonix standard
 test plans and Mil-Std-202
 Test Methods.

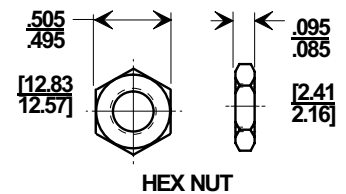
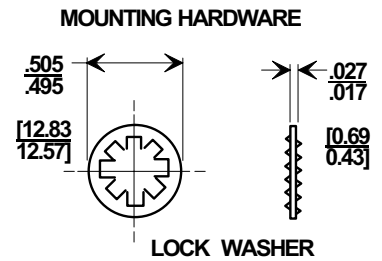
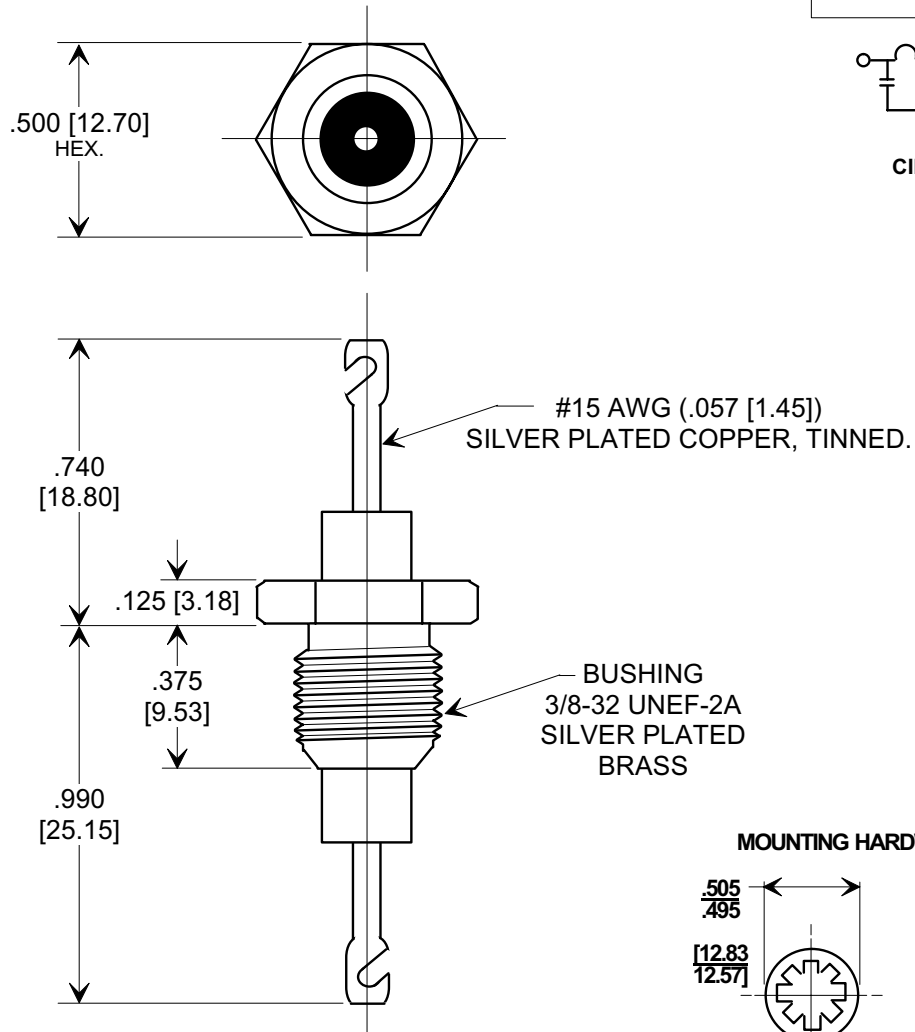
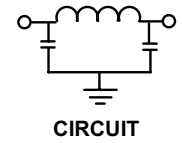
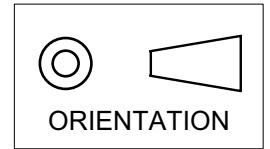

NOTES:

- TUSONIX STANDARD PART NUMBER: 4208-000.
 TUSONIX RoHS COMPLIANT PART NUMBER: 4208-000 LF.
 CUSTOMER MUST SPECIFY STANDARD OR RoHS PART NUMBER WHEN ORDERING.
- SUPPLIED WITH SILVER PLATED LOCK WASHER AND NUT.
- PART MARKING: TRADEMARK AND VARIATION NUMBER ON HEX FLATS.
 STANDARD PART: BLACK INK. RoHS PART: GREEN INK.

MIN. Cx.	WORKING VOLTAGE		DWV (VDC)	CURRENT IDC	MINIMUM NO LOAD INSERTION LOSS (dB) AT 25°C PER MIL-STD-220			
	85° C	125° C			10MHz	100MHz	1GHz	10 GHz
1500 pF	2500	2000	5 KV	25A	5	50	50	50

X-2015 Rev-0	REVISION RECORD						--TOLERANCES-- Unless Otherwise Specified	Title HI-VOLTAGE EMI FILTER		
	0	Original Release C.O.	1	WAS SK 6959-000. KLJ 5-1-90	2	ADDED COLUMN (IDC) & HARDWARE. E.C. 07-03-90				DECIMAL ± .031 [0.79]
	1	REISSUE -375 DIM. WAS .347. KLJ. 5-4-90	3	RDN TO COMP FMT & METRIC ADDED. S.M. 05-28-02	4	20020523-4-10	ANGLES ±	Drawn S.M. 05-28-02	Scale 2X	
	5183		5365		20050718-5-02	ADDED NOTES. S.M. 07-27-05	TUSONIX TUCSON, ARIZONA	Approved J.Mc. 05-28-02	A	4208-000
	5183									