

MOSFET BASED DC SOLID-STATE RELAY



- ▶ Latest MOSFET technology generation.
- ▶ Ultra low on-state resistance.
- ▶ New innovative isolated driver ensuring fast power transistor turn on and off therefore low power transient.
- ▶ Ultra low output leakage current
- ▶ Low control current consumption
- ▶ Triggered control input to avoid linear control risks
- ▶ Low conducted and radiated disturbances

SCM0150100



Control voltage range	4.5-32VDC
Max transient peak voltage	100v
Advised max. DC Mains peak voltage	Depend on the voltage protection
Max. Load Current (with heatsink)	150ADC

DC Mains voltage range	Load current range	Control input voltage range	In & case / Out Insulation	Connections	Dimensions (WxHxD)	Weight
(Depends on protection clamping voltage)	0 to 150A (with heatsink)	4.5-32VDC	4kV	M3 round tabs M5 round tabs	44.5 x 58.2 x 27 (mm)	100g

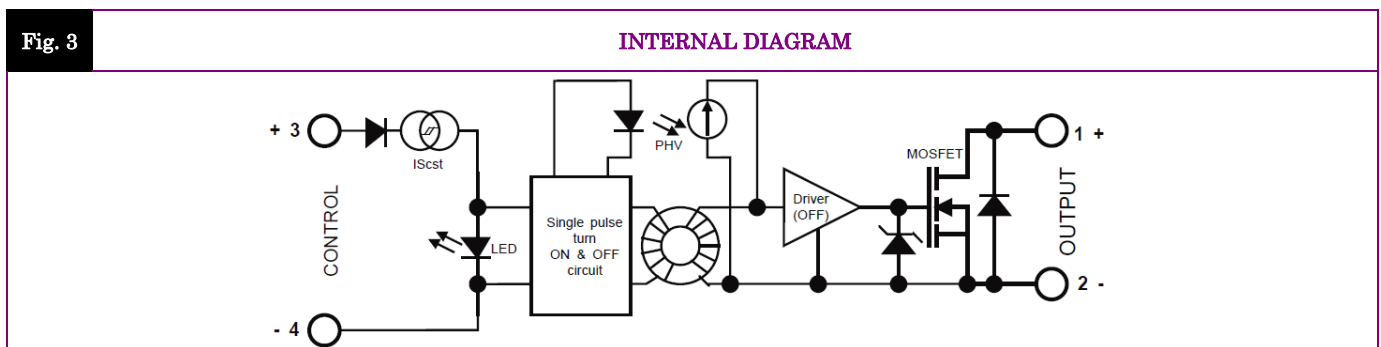
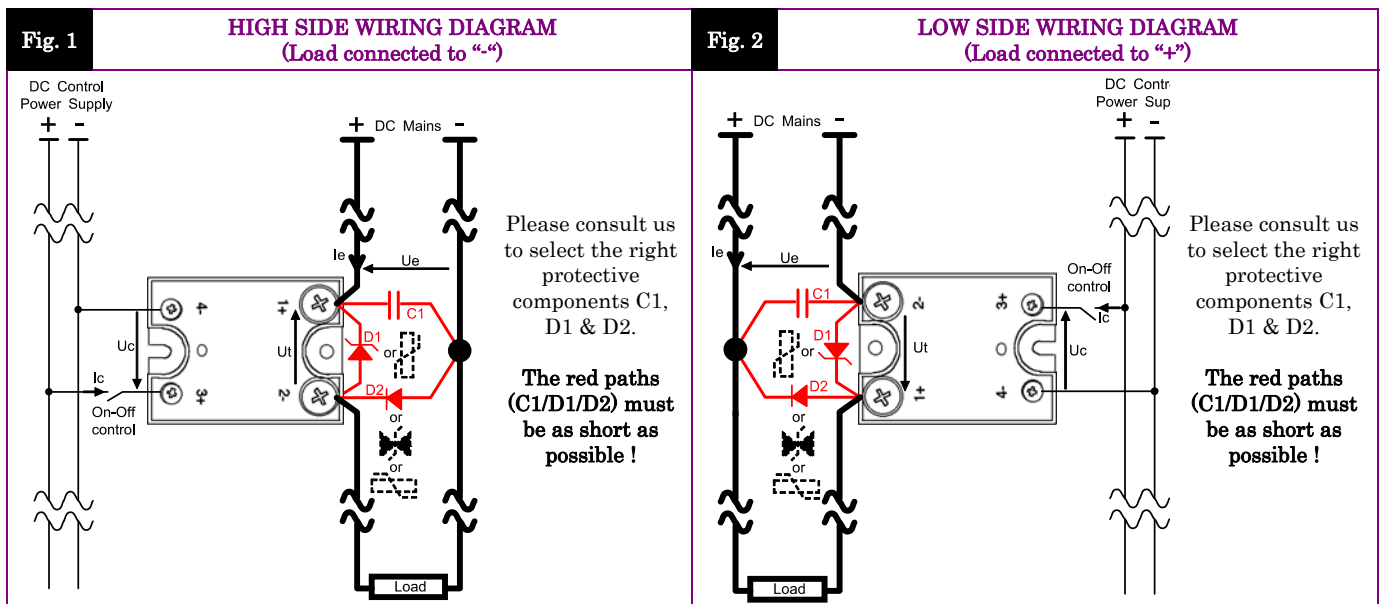

Proud to serve you

CONTROL INPUT CHARACTERISTICS

INPUT CIRCUIT	CHARACTERISTIC	LABEL	VALUE	INFO.	Fig. 4 CONTROL CURRENT vs. CONTROL VOLTAGE
	Nom. Control voltage	U_{Cnom}	12-24VDC		
	Nom. Control current	I_{Cnom}	35mADC		
	Control voltage range	U_c	4.5 – 32VDC	typical=4.3V	
	Control current consumption	I_c	25 – 42mADC	See curve	
	Releasing control voltage	U_{Coffmax}	1VDC	Typical= 3.5V	
	Max. reverse control voltage	-U_{Cmax}	32VDC	-I _{cmax} <100µA	
	Input impedance	R_{in}	Current limitation	See curve	

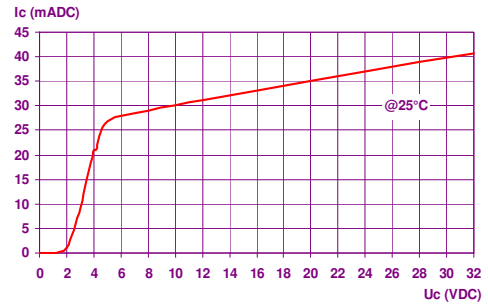

TIME CHARACTERISTICS

TIME CHARACT.	CHARACTERISTIC	LABEL	VALUE		
	Turn on time	ton	10µs		
	Turn on delay	tdon	600µs		
	Turn off time	toff	10µs		
	Turn off delay	tdoff	100µs		
Max. On-Off frequency	F_(on-off)	700Hz			

POWER OUTPUT CHARACTERISTICS

POWER CIRCUIT	CHARACTERISTIC	LABEL	VALUE	INFO.	
	Mains voltage range	U_t U_e	Min = R_{DSon} x I_e		Depends on protection clamping voltage (D1)
	Non-repetitive peak voltage	U_{tp}	100V		
	Overvoltage protection	D1	Not integrated A voltage clamping mean must be connected across the terminals 1 & 2 (see fig 1 & 2)		Please consult us to select the right protective components
	Off-state max reverse voltage drop (internal diode)	-U_t	0.85V		@I _e =150A @U _c =0
	Maximum nominal currents	I_{e max}	Resistive 150A	Motor Please contact us	See fig. 9
	Max. non-repetitive peak current	I_{epeak}	1000A		See fig. 8
	Min. load current	I_{emin}	0mA		
	Max. leakage current	I_{elk max}	500µA		@U _{tp} @T _{jmax}
	Max. on-state resistance	R_{DSon}	1mΩ @T _j =25°C	1.9mΩ @T _j =125°C	@I _{emax}
	Typ. output capacitance	C_{out}	2.7nF		@U _{tp}
	Junction/case thermal resistance	R_{thjc}	0.45K/W		
	Built-in heatsink thermal resistance vertically mounted	R_{thra}	10K/W		@ΔT _{ra} =75°C
	Heatsink thermal time constant	T_{thra}	10 minutes		@ΔT _{ra} =60°C
	Control inputs/power outputs insulation voltage	U_{imp}	4kV		
	Inputs/case insulation voltage	U_{imp}	4kV		
	Outputs/case insulation voltage	U_{imp}	4kV		
	Isolation resistance	R_{io}	1GΩ		
	Isolation capacitance	C_{io}	<8pF		
	Maximum junction temperature	T_{jmax}	175°C		
	Storage ambient temperature	T_{stg}	-40->+100°C		
	Operating ambient temperature	T_{amb}	-40->+90°C		See fig. 9
	Max. case temperature	T_c	100°C		

OUTPUT SWITCH CHARACTERISTIC CURVES

Fig. 5 ON RESISTANCE VS JUNCTION TEMPERATURE

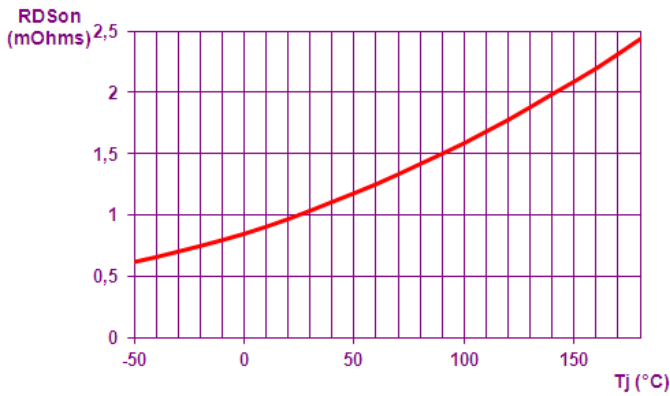

Fig. 6 REVERSE VOLTAGE DROP VS REVERSE CURRENT

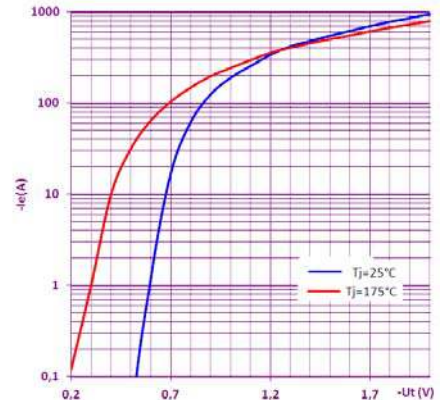

Fig. 7 POWER ELEMENT TRANSIENT THERMAL IMPEDANCE vs. PULSE DURATION

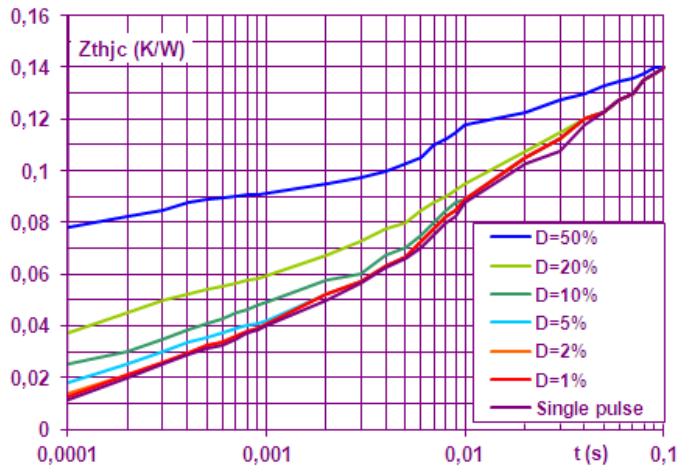

Fig. 8 ON-STATE PEAK OVERLOAD CURRENT vs. PULSE DURATION

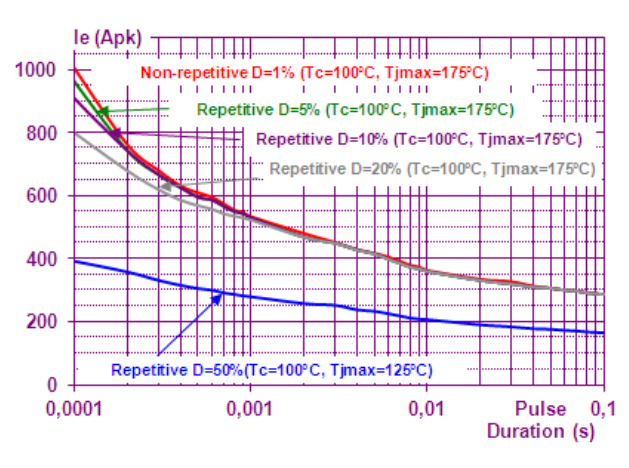
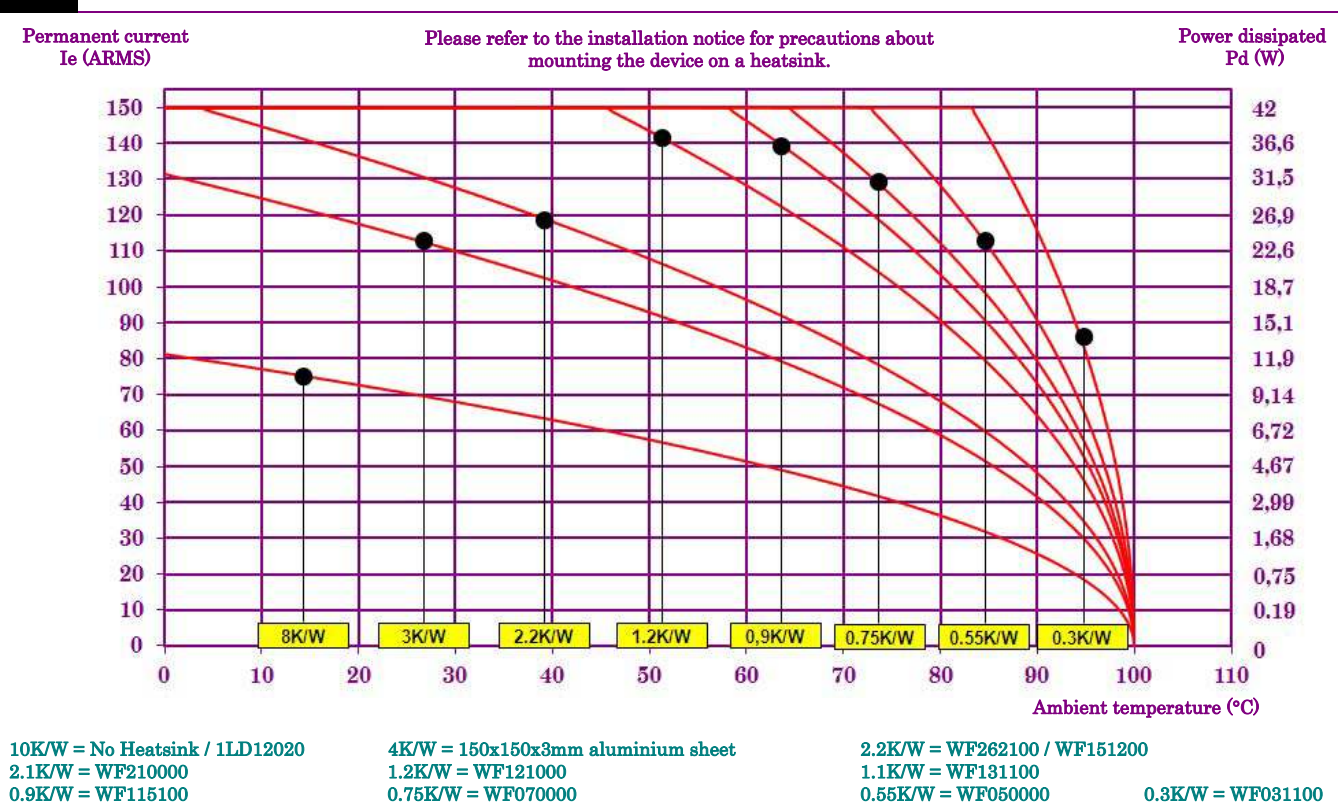

Fig. 9 POWER DISSIPATED AND LOAD CURRENT LIMIT VS TEMPERATURE



GENERAL INFORMATION

CONNECTIONS	Connections		Power	Control	
	Screwdriver advised		Philips™ NR2	Philips™ NR1	
	Min and max tightening torque		1.8 N.m	0.8 N.m	
	Insulated crimp terminals (round tabs, eyelet type)		M5	M3	
MISC.	Display		Green LED (indicates relay has switched ON)		
	Housing		UL94V0		
	Mounting		2 screws (M4x12mm)		See mounting sheet
	Noise level		No audible noise		
	Weight		100g		

STANDARDS

GENERAL	Standards		IEC60947-1	
	Protection level		IP00	
	Protection against direct touch		None	
	CE marking		Yes	
	UL, cULUS		Yes	
E.M.C. IMMUNITY	TYPE OF TEST	STANDARD	LEVEL	EFFECT
	E.S.D. (Electrostatic discharges)	EN61000-4-2	Pending	?
	Radiated electromagnetic fields	EN61000-4-3	Pending	?
	Fast transients bursts	EN61000-4-4	Pending	No effect
	Electric chocks	EN61000-4-5	Pending	?
	Voltage drop	EN61000-4-11	-	
E.M.C. EMISSION	Radiated and conducted disturbances	NFEN55011	Pending	

DIMENSIONS AND ACCESSORIES

Fig. 10

DIMENSIONS (mm)

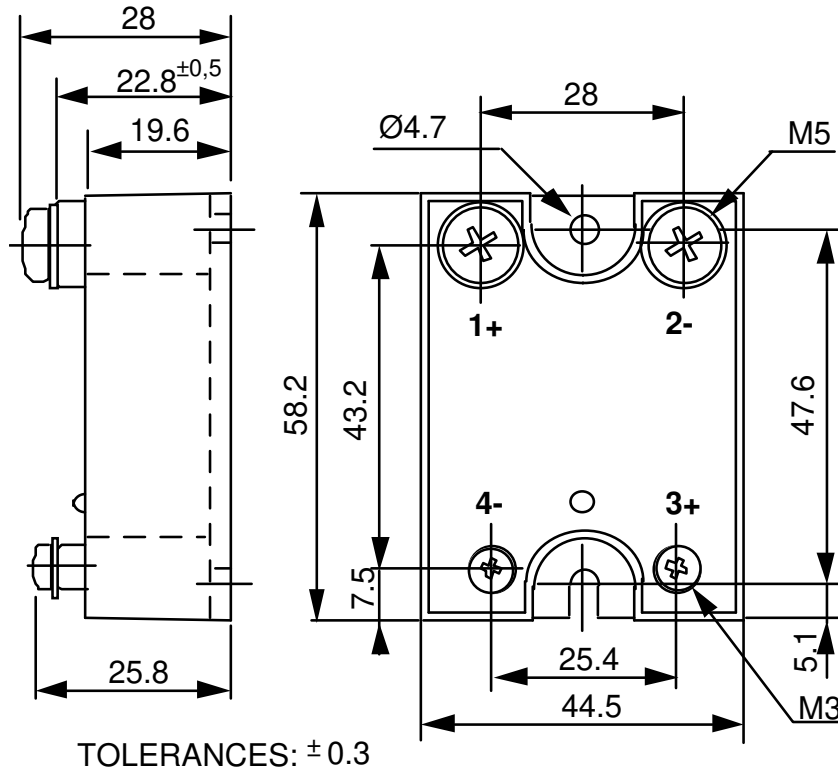

ACCESSORIES

PROTECTIVE COVER
1K470000

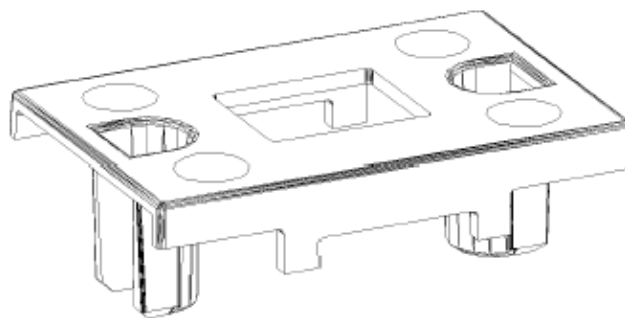

Please consult our website for other accessory references
(Heatsinks, mounting adaptors, thermal grease...)