

#### Product Configuration

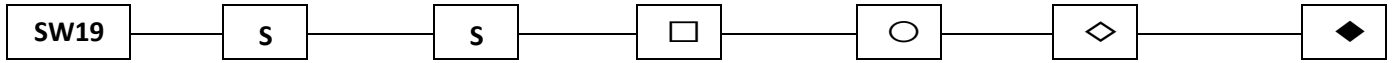

<b>Series</b> Ø19mm	<b>Bezel Material</b> S: Stainless steel	<b>Terminal</b> S: Screw	<b>□ Operation Type</b> M: Momentary L: Latching	<b>○ LED Styling</b> 0: None 1: Dot 2: Ring 3: Power	<b>◇ LED Colour</b> 1: Red 2: Green 3: Yellow 4: Orange 5: Blue 6: White	<b>◆ LED Voltage</b> 1: 6V 2: 12V 3: 24V 4: 36V 5: 110V 6: 240V
------------------------	---	-----------------------------	--	--	--	---

#### Example Part Numbers

SW19SSM0 Momentary, No LED  
 SW19SSL253 Latching, Ring Styling, Blue LED @ 24V



#### Specifications

Voltage / Current Rating	250V / 5A (AC)	Ingress Protection	IP 65
Contact Resistance	≤ 50mΩ	Impact Rating	IK 10
Insulation Resistance	≥ 1,000MΩ	Operating Force	3 – 5 N
Dielectric Strength	1,780V (AC)	Operating Travel	3 mm
Mechanical Life	≥ 1,000,000 cycles	Panel Thickness Range	1 – 10 mm
Electrical Life (Full Load)	≥ 50,000 cycles	Torque	5 – 14 N
Contact Configuration	1 NC, 1 NO	Contact Material	Silver alloy
Soldering	n/a	Operating Temp. Range	-40 to +80°C

#### Contact Configuration / Circuit Diagram

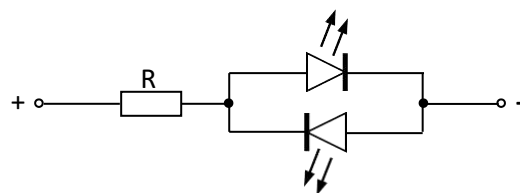
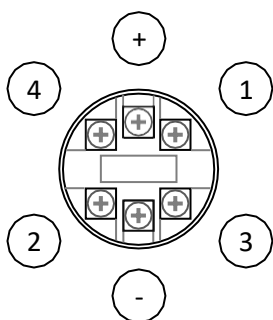

The LED illumination is polarity insensitive

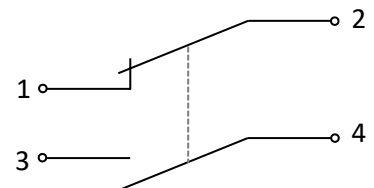

**Outline Dimensions (mm) - Not to scale**

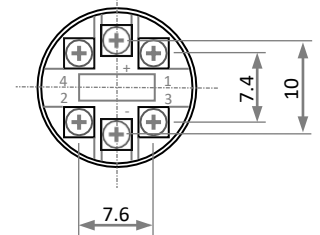
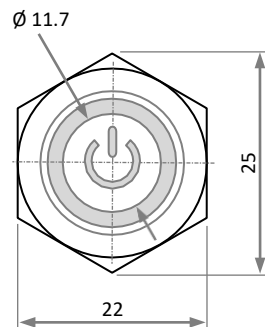
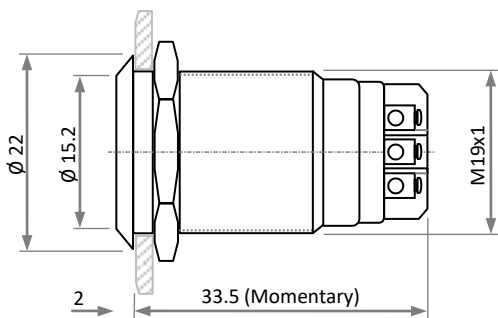
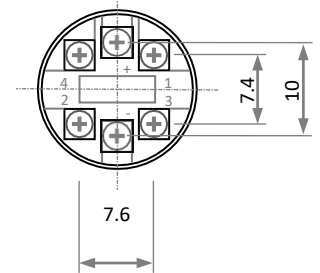
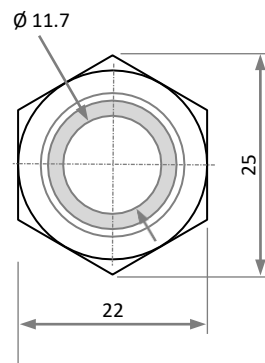
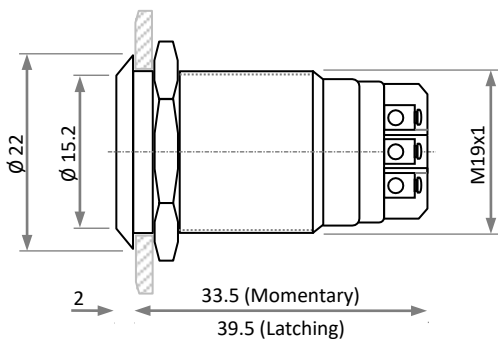
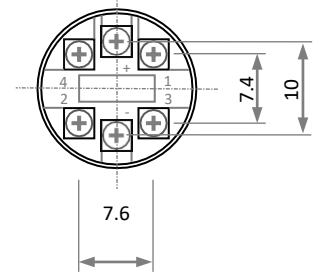
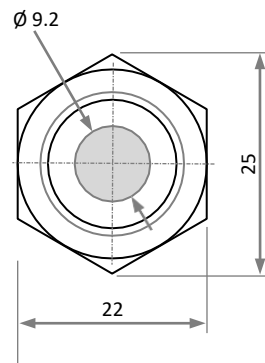
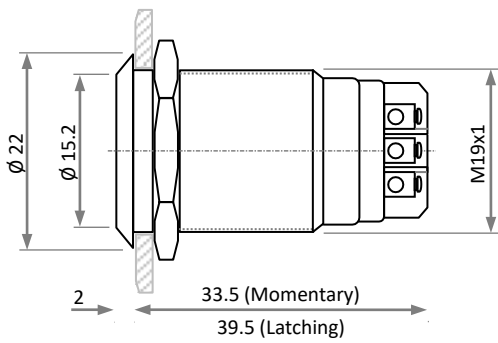
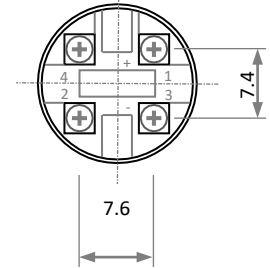
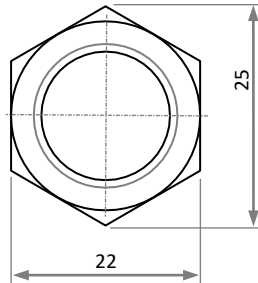
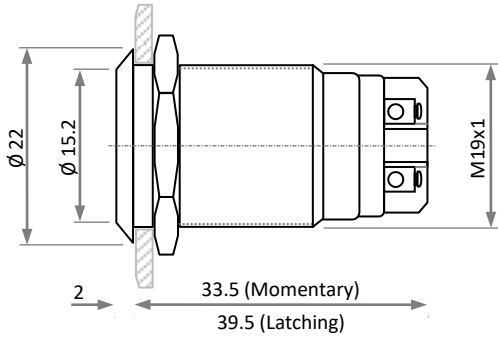



## PRODUCT DATA SHEET

SW19SS Series

Ø19mm stainless steel pushbutton switches



Outline Dimensions (mm) - Not to scale

39.5 (Latching)