

DATE	REV	ECN	APP'D. BY
10/22/20	A0	RELEASED	GWL
3/17/21	A1	11716	JME
04/12/21	A2	11731	GWL

B

B

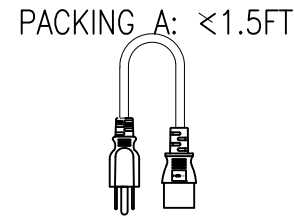
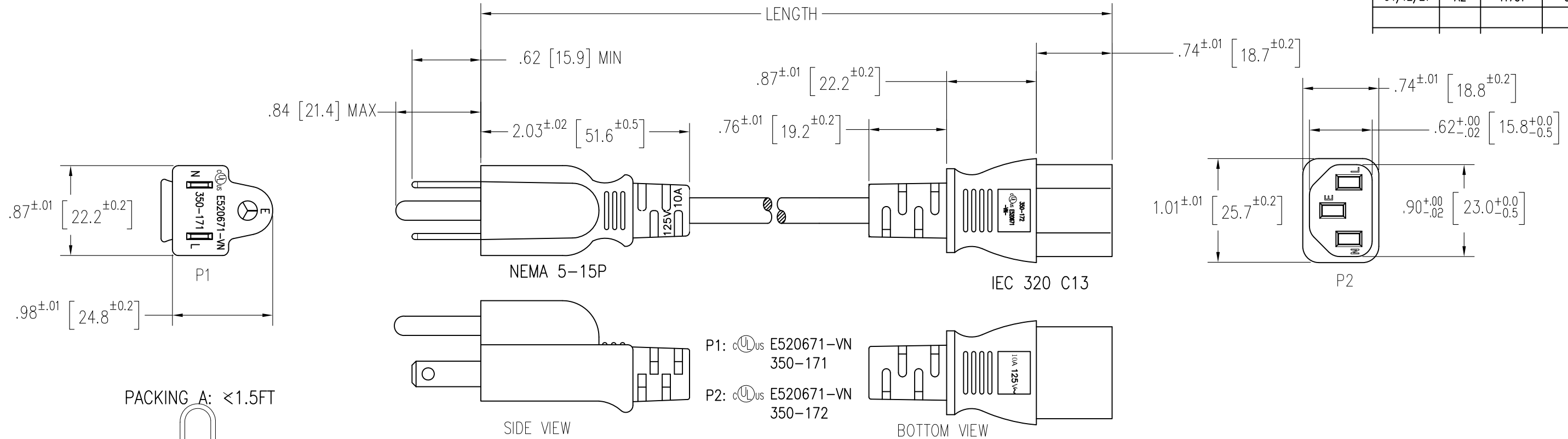

PACKING B: 2 FT [.6 M] – 10 FT [3M]

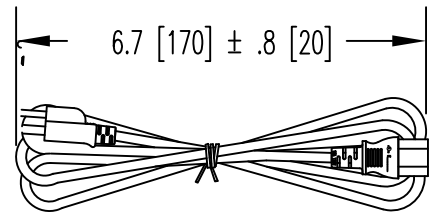

PACKING C: > 10 FT [3M]

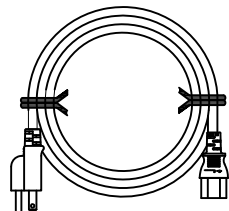

P/N Key:

PC-AB K XXX X

Length

- 001 F = 1 Ft
- 002 F = 2 Ft
- 003 F = 3 Ft
- 005 F = 5 Ft
- 006 F = 6 Ft
- 010 F = 10 Ft
- 012 F = 12 Ft
- 015 F = 15 Ft
- 025 F = 25 Ft
- 010 M = 1 M
- 020 M = 2 M
- 030 M = 3 M

NOTES:

1. SPECIFICATIONS:  
 RATING: 10A 125V AC  
 CABLE TYPE: UL SVT 18AWG 3C, OD 6.3mm COLOR BLACK  
 CABLE MARKING: (UL) SVT 3/C 18AWG (0.824MM<sup>2</sup>) VW-1 75°C 300V E204978 C(UL)  
 SVT 3/C 0.824MM<sup>2</sup> (18AWG) FT2 60°C 300V E204978 MSL-VN-  
 END "P1": NEMA 5-15P, MOLDED PVC 35P, COLOR BLACK  
 END "P2": IEC 320 C13, MOLDED PVC 35P, COLOR BLACK
2. ALL RELEVANT MATERIALS ARE COMPLIANT WITH RoHS DIRECTIVE.
3. APPROVALS: UL cUL
4. TESTING:  
 4.1. 100% CONTINUITY/SHORT  
 4.2. HIPOT INTERNAL 2KV LASTING 1 SEC; EXTERNAL 2.5 KV. LASTING 1 SEC
5. OPERATING TEMPERATURE: -4° F (-20° C) TO 140° F (60° C)
6. HUMIDITY RANGE 10-85% RH



THIRD ANGLE PROJECTION

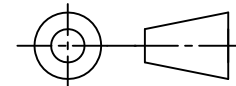

DRAWING IS SUBJECT TO CHANGE WITHOUT NOTICE

Cable Length Unless Other Spec.  
 Tolerances:  
 0 ~ 3.3 Ft [1M] ± .79 IN [20mm]  
 3.4 Ft [1.1M] ~ 5 Ft [1.5M] ± .98 IN [25mm]  
 5.1 Ft [1.6M] ~ 6.9 Ft [2M] ± 1.2 IN [30mm]  
 7.0 Ft [2.1M] ~ ↑ ± 1.6 IN [40mm]

DO NOT SCALE DRAWING

SHEET NO. 1 OF 1

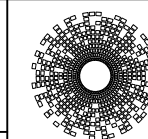

**stewart**  
 CONNECTOR  
 a bel group

11118 Susquehanna Trail South  
 Glen Rock, PA 17327-9199  
 (717) 235-7512  
<http://www.stewartconnector.com>

TITLE: POWER SUPPLY CORDS

THIS DRAWING AND THE SUBJECT MATTER SHOWN THEREON ARE CONFIDENTIAL AND THE PROPRIETARY PROPERTY OF STEWART CONNECTOR AND SHALL NOT BE REPRODUCED, COPIED, OR USED IN ANY MANNER WITHOUT PRIOR WRITTEN CONSENT OF STEWART CONNECTOR. ONE OR MORE U.S. PATENTS MAY APPLY TO THIS PRODUCT. FOR DETAILS, PLEASE VISIT: [HTTP://BELFUSE.COM/STEWART/STEWART\\_PATENTS/](http://BELFUSE.COM/STEWART/STEWART_PATENTS/)

DRN BY:	GWL	DATE	10/15/20
APPD BY:	AB	DATE	10/19/20
DWG NO.	CT999229	REV.	A2

A

A