

| REV. | DATE | DESCRIPTION |
|------|----------|--|
| NC | 05/22/00 | INITIAL RELEASE |
| A | 07/16/07 | UPDATE DRAWING FORMAT |
| B | 01/09/08 | REVISE BODY MATERIAL TO DIECAST, PLATING TO NICKEL |

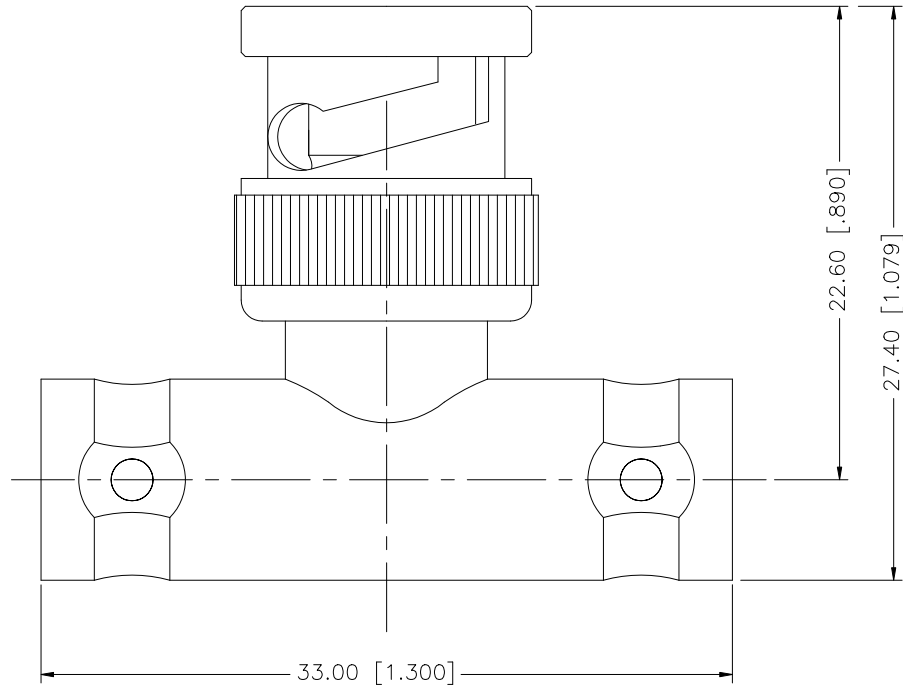

| | | | | | | | | |
|---|-------------|----------|---------|---|-----------|-------------------|--|------------|
| 8 | | | | <p>UNLESS OTHERWISE SPECIFIED DIMENSIONS ARE IN MILLIMETERS. DIMENSIONS IN [] ARE IN INCHES AND FOR CUSTOMER REFERENCE ONLY.</p> <p>UNLESS OTHERWISE SPECIFIED TOLERANCES FOR MILLIMETERS ARE: 0.5 - 8mm ± 0.20mm 8 - 30mm ± 0.40mm 30 - 120mm ± 0.50mm</p> <p>UNLESS OTHERWISE SPECIFIED TOLERANCES FOR INCHES ARE: .020 - .315 = ± 0.007" .315 - 1.180 = ± 0.015" 1.180 - 4.724 = ± 0.020"</p> <p>DO NOT SCALE DRAWING</p> | APPROVALS | DATE | <h1 style="color: blue;">Amphenol Connex</h1> <p>PART DESCRIPTION BNC "T" ADAPTER / JACK-PLUG-JACK 50ohm</p> | |
| 7 | | | | | DRAWN | G.R.S. | | 01/09/08 |
| 6 | | | | | CHECKED | | | |
| 5 | | | | | ISSUED | | | |
| 4 | | | | | SHEET | 1 OF 1 | | |
| 3 | CONTACT PIN | BRASS | GOLD | 1 | | | PART NO. | 112461 |
| 2 | INSULATOR | DELRIN | NATURAL | 1 | | | DWG. NO. | 112461.DWG |
| 1 | BODY | DIECAST | NICKEL | 1 | | | REV. | B |
| | DESCRIPTION | MATERIAL | FINISH | QTY | | CAD FILE | SIZE | A |
| | | | | | | C:/112/112461.DWG | SCALE | NA |