

DH1 series

Thumb wheel switches



DISTINCTIVE FEATURES

Diameter 13 mm

Width 16 mm

SMT Gull Wing

10 Position BCD



ENVIRONMENTAL SPECIFICATIONS

- Operating temperature: -50 °C to +125 °C (-58 °F to +257 °F)
- Storage temperature: -55 °C to +135 °C (-67 °F to +275 °F)
- Humidity : 21 days at 40 °C (104 °F) 93% RH



ELECTRICAL SPECIFICATIONS

- Operating voltage : 42 VDC max.
- Contact load, static : 400 mA max.
- Contact load, dynamic : 100 mA max.
- Initial contact resistance : 80 mΩ max.
- Insulation resistance : 100 MΩ min.
- Minimum load : 1 μA 20 mVDC
- Insulation resistance : 100 MΩ min.
- Test voltage: 250 V 50 Hz / 1 min



MECHANICAL SPECIFICATIONS

- Torque : 1.2 Ncm ± 0.2
- Mechanical lifetime : min. 25 000 steps

The company reserves the right to change specifications without notice.



DH1 series

Thumb wheel switches



MATERIALS

- Housing : plastic
- Cover : stainless steel
- Fixed contact, pins : copperalloy
- Moveable contacts : copperalloy
- Contact surface : hardgold
- Rotor: plastic
- O-ring : rubber
- Washer : stainless steel
- Wheel : plastic



SOLDERING

- Reflow soldering : 260 °C (500 °F) max. for 10 seconds max.



PACKAGING

- Tape and Reel

DH1 series

Thumb wheel switches



BUILD YOUR PART NUMBER

DH1	_____	_____	SMT	_____								
SERIES	CODES	FOR PCB	CONTACT PINS	COLORS, PRINTING, OTHER VERSIONS								
	01A BCD 10 Positions	L Left R Right		<table border="1"> <tr> <td>001</td> <td>Thumb wheel black, printing white, 1-10, with crown</td> </tr> <tr> <td>002</td> <td>Thumb wheel black, printing white, 1-10, without crown</td> </tr> <tr> <td>003</td> <td>Thumb wheel black, printing white, 0-9, with crown</td> </tr> <tr> <td>004</td> <td>Thumb wheel black, printing white, 0-9, without crown</td> </tr> </table>	001	Thumb wheel black, printing white, 1-10, with crown	002	Thumb wheel black, printing white, 1-10, without crown	003	Thumb wheel black, printing white, 0-9, with crown	004	Thumb wheel black, printing white, 0-9, without crown
001	Thumb wheel black, printing white, 1-10, with crown											
002	Thumb wheel black, printing white, 1-10, without crown											
003	Thumb wheel black, printing white, 0-9, with crown											
004	Thumb wheel black, printing white, 0-9, without crown											

WITHOUT OPERATING CROWN

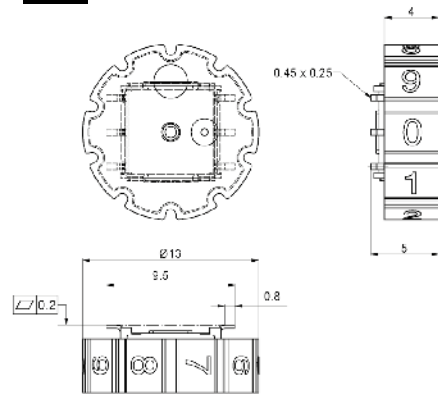

WITH OPERATING CROWN

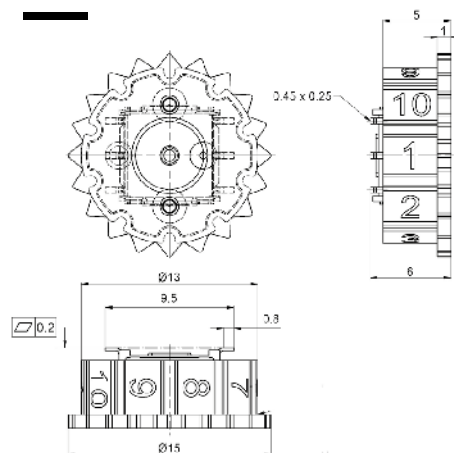

DH1 series

Thumb wheel switches

CODES

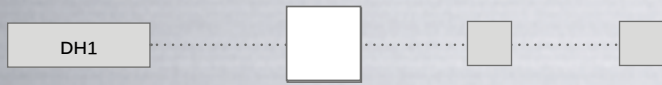

01A BCD 10 Positions

POSITION MARKING

POSITION	C	1	2	4	8	MARKING
0	●					1
1	●	●				2
2	●		●			3
3	●	●	●			4
4	●			●		5
5	●	●		●		6
6	●		●	●		7
7	●	●	●	●		8
8	●				●	9
9	●	●			●	10

Left

POSITION MARKING

POSITION	C	1	2	4	8	MARKING
0	●					1
9	●	●			●	2
8	●				●	3
7	●	●	●	●		4
6	●		●	●		5
5	●	●		●		6
4	●			●		7
3	●	●	●			8
2	●		●			9
1	●	●				10

Right

FOR PCB



L Left
R Right

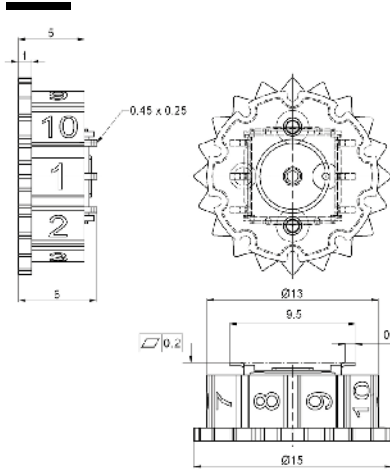

Left

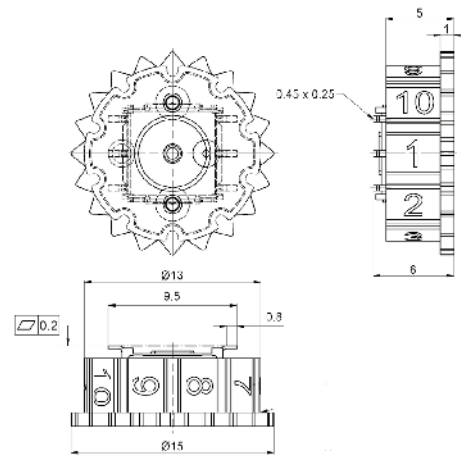

Right

CONTACT PINS

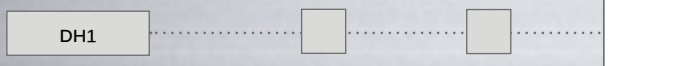

SMT

