

## ■ Selection of PM Motors

These motors offer high precision at a low price and are used in a wide array of office automation equipment as well as various other applications. Our PM motor offering spans a large range of motor sizes or output torques. We pride ourselves on our design and manufacturing systems that ensure the rapid delivery of motors perfectly suited to their applications. On this page we list several parameters that can be used in the selection of a PM motor.



Depending on the application, the conditions of use, and the model in which the motor will be used, it is necessary to set motor characteristics for optimum conditions. We therefore recommend, in addition to making a selection based on information on this website, that you order a variety of samples and conduct an evaluation of the products when in use in the actual equipment. Please contact your local sales representative or e-mail us for sample order.

### Index

1) Selection in view of Torque Requirements (1) . . . . .	2
2) Selection in view of Torque Requirements (2) . . . . .	3
3) Setting of Resistance Value . . . . .	4
4) Condition of Temperature . . . . .	5
5) Selection of Magnet (1) . . . . .	6
6) Selection of Magnet (2) . . . . .	7
7) Choice of Coil Extension Method . . . . .	8
8) Selection of Gear, Pulley etc. . . . .	9
9) Choice of Combination of Standard Parts . . . . .	10
10) Description of Standard Dimensions (1) . . . . .	11
11) Description of Standard Dimensions (2) . . . . .	12
12) Drive Circuitry and Wiring Diagram . . . . .	13,14,15

These pages do not constitute any part of the product specifications and are intended only as reference material in aiding with the selection of a motor. Also, please note that the contents of these page are liable to change without notice. Even if there are any changes to the information given here, this will have no influence whatsoever on products for which specifications have already been agreed and which are in production. If there should be any impact on products already manufactured, we will submit a request for approval of changes to the customer, and make any such changes only after receiving the customer's agreement.

## ■ Selection in view of Torque Requirements (1)

The torque generated by a motor is determined by the size of the motor. Also, the heat resistance temperature of the magnet wires used in the motor limits the maximum torque for each motor size. UL and other safety standards impose further limitations. These specify that the motor surface should normally be at 105°C. In addition, when UEW (polyurethane wire: class E) is used the magnet wire heat resistance temperature is a maximum 120°C. We cannot guarantee reliability if the coil is used at temperatures exceeding this.

Torque Range According to Motor Size

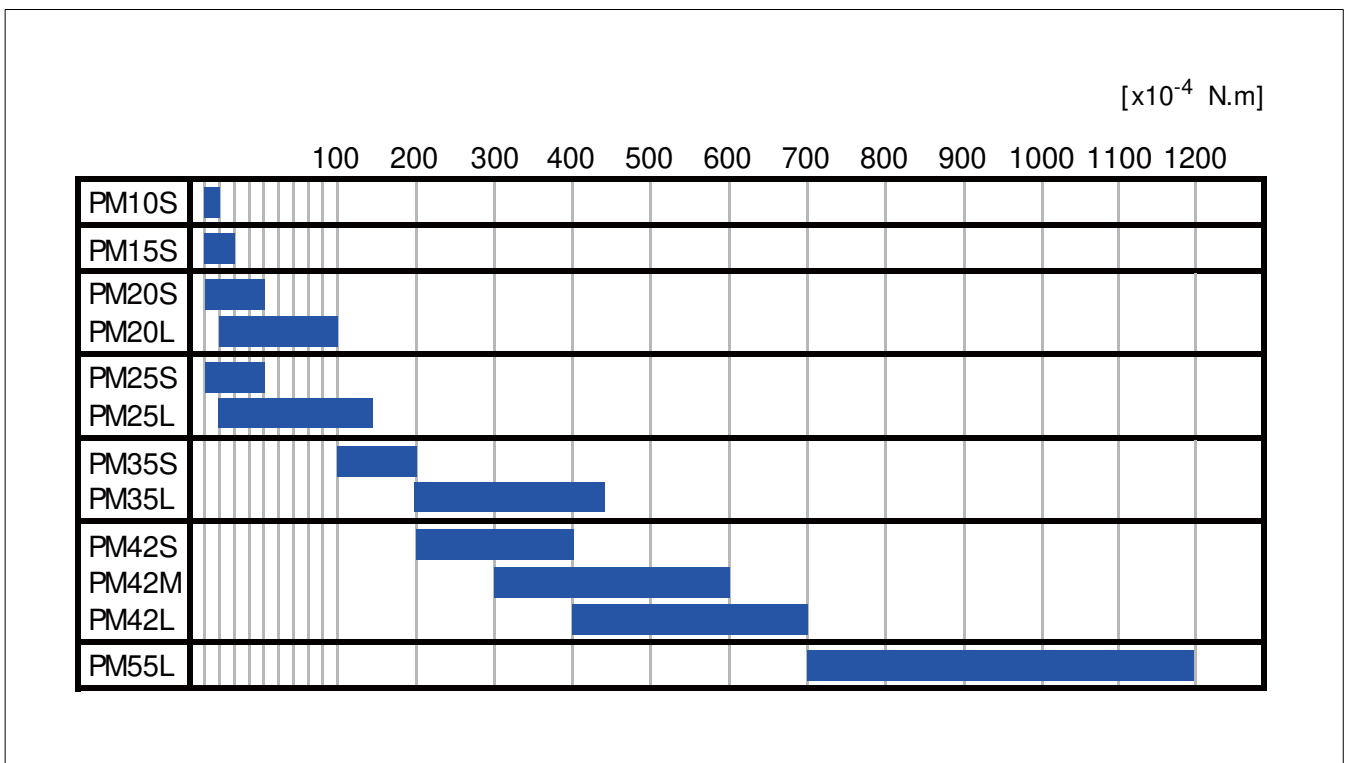

The above graph shows output torque range by motor size. Within this range, coil resistance and magnet materials can be tailored for optimum motor settings. For Nd-Fe-B bonded magnets only, it is possible to control magnetization, and it is therefore possible to make adjustments to rotor flux.

## ■ Selection in view of Torque Requirements (2)

The output torque of a motor varies according to the drive speed. Even if the motor is driven at the same voltage, the rise in revolution speed leads to increased occurrence of electrical motive force, and to higher coil impedance. This in turn makes it harder for current to flow through the coil, thus lowering torque. The following graphs list the average torque for each size of motor. Please refer to this information in making your selection.

PM10S ~ PM25L

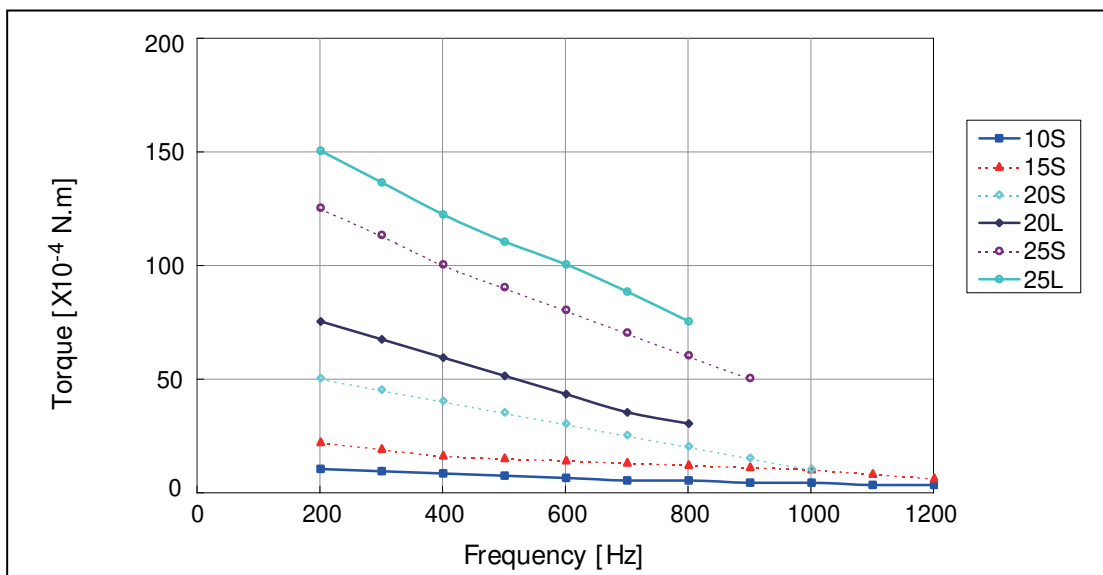

Magnets for sizes PM15 to PM25 mainly display MS70 characteristics.

PM35 ~ PM55

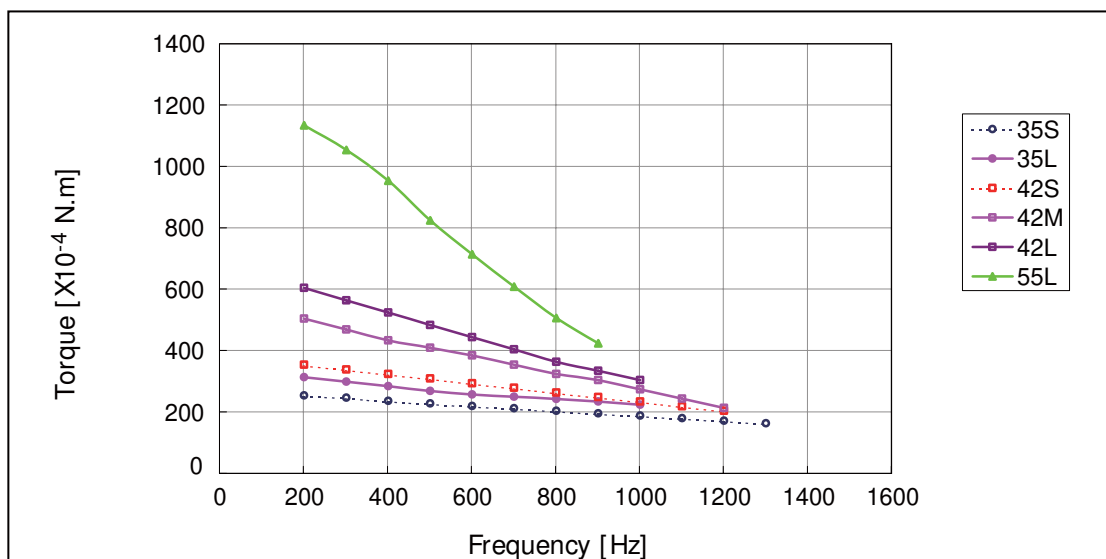

Magnets for sizes PM35 to PM42 mainly display MS50 characteristics, While magnets for size PM55 display MSPL characteristics.

## ■ Setting of Resistance Value

Resistance value is restricted by service voltage and rise in motor temperature. Further, there are limitations on potential settings due to considerations of power conservation and restrictions on power supplies and motor drivers receiving power. Please pay due attention to these limitations when deciding settings. In addition, coil winding volume is restricted by motor size, so please refer to the following resistance value ranges when establishing settings. If priority is placed on torque, after taking temperature rise into account we can establish settings here by ourselves. In this case, please inform us of the drive conditions, the level of duty, the method of attachment, temperature conditions during use, and any or all other necessary specifications.

### Resistance Value Range According to Motor Size

		100	200	300	400	500	600	700	800	900	1000	1100	1200
PM10S	4.0Ω MIN	60Ω MAX											
PM15S	4.0Ω MIN	137Ω MAX											
PM20S	2.4Ω MIN	190Ω MAX											
PM20L	3.0Ω MIN	300Ω MAX											
PM25S	2.5Ω MIN	200Ω MAX											
PM25L	4.0Ω MIN	500Ω MAX											
PM35S	2.2Ω MIN	745Ω MAX											
PM35L	3.0Ω MIN	800Ω MAX											
PM42S	1.6Ω MIN	800Ω MAX											
PM42M	2.2Ω MIN	1000Ω MAX											
PM42L	2.4Ω MIN	1000Ω MAX											
PM55L	3.9Ω MIN	1000Ω MAX											

## ■ Condition of Temperature

The major factor limiting output torque is the temperature of the motor coil. It is therefore necessary to gain an understanding of the temperature characteristics of the motor under conditions of normal usage. Also, the surface area varies according to motor size, and radiation characteristics therefore also naturally vary, leading to changes in motor temperature. The following shows the major characteristics of our motors. Please pay particular attention to this information when selecting a motor.

### Coil temperature rise per 1W input

PM15S	PM20S	PM20L	PM25S	PM25L	PM35S	PM35L	PM42S	PM42M	PM42L	PM55L
54	35	31	30	26	19	16	15	14	13	8

\* If input power (W) is multiplied by the relevant value above, you can gain a rough estimate of the coil temperature.

### Ratio between motor surface temperature and coil temperature

PM15S	PM20S	PM20L	PM25S	PM25L	PM35S	PM35L	PM42S	PM42M	PM42L	PM55L
0.9	0.91	0.91	0.91	0.91	0.88	0.87	0.87	0.88	0.88	0.87

\* If you measure the motor surface temperature and divide that figure by the relevant value above, you can gain a rough estimate of the coil temperature.

### Time to reach coil temperature saturation

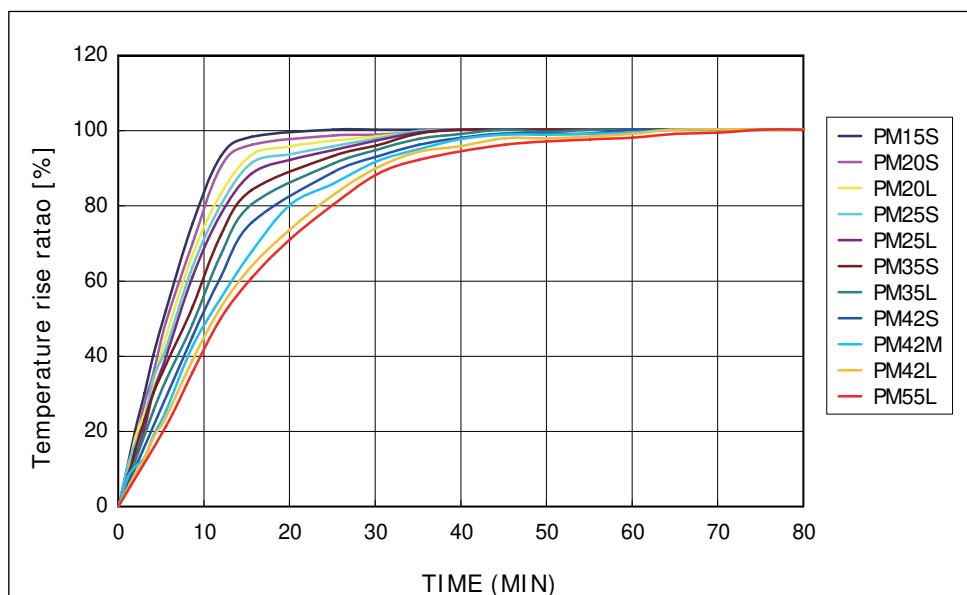

The graph shows the amount of time until the coil reaches saturation temperature.

This information allows you to judge when overdrive is possible for a short time, such as when the motor is operating under light duty conditions of use.

## ■ Selection of Magnet (1)

We provide three different materials for magnets, the choice depending on the necessary torque and rotor inertia requirements, etc. Please note that the price of magnets varies depending on the material. In principle, we make the selection of material ourselves, doing our very best to keep prices low while ensuring the necessary torque. Of course, you, as our customer, can also specify the magnet material that you require. We have two methods of assembling the rotor - adhesive type, or plastic molding - and the selection of method is based on a consideration of the difference in cost and manufacturing technology. Depending on the assembly method used, there are variations in cost and rotor inertia.

### Combination of Motor Size and Magnet Material

- MSPL ----- Ferrite plastic magnet
- MS50 ----- Polar anisotropy ferrite sintered magnet
- MS70 ----- Nd-Fe-B bonded magnet

	MSPL	MS50	MS70
PM10S			
PM15S			
PM20S			
PM20L			
PM25S			
PM25L			
PM35S			
PM35L			
PM42S			
PM42M			
PM42L			
PM55L			

## ■ Selection of Magnet (2)

The differences in torque arising from the choice of magnet material are roughly as shown below.  
The figures are shown as an index conversion value where MS50 is 100.

MSPL	75
MS50	100
MS70	115



Standard Inertia for Each Motor Size

[g·cm<sup>2</sup>]

	MSPL	MS50		MS70	
		MOLD	ADHESIVE	MOLD	ADHESIVE
PM10S					0.02
PM15S					0.04
PM20S					0.30
PM20L					0.43
PM25S			0.72		0.67
PM25L			1.17		0.88
PM35S	2.86		4.84	2.85	3.51
PM35L	5.15	7.75	7.81	4.47	5.79
PM42S	8.1	11.37	13.91	7.36	10.26
PM42M	8.01	14.36		7.03	
PM42L	12.91	22.09	22.82	11.08	18.53
PM55L	41.3	80.02	92.14	33.2	60.13

\* For MS50 and MS70, the mold type is the standard specification. An adhesion type is applied only at the demand on characteristic (a big inertia is needed) etc., while it becomes factor a cost-up.

## ■ Choice of Coil Extension Method

Minebea offers a variety of methods to enable customers to choose a coil extension method suitable for the equipment that they are using, while keeping total costs to the very minimum. We also include some general examples of applications, for reference use during the selection process.

### 1) Wire Holder Method

In this method, the wire is directly soldered to the coil terminal of the motor, via the PCB. This is an effective method when there is little room to spare with the dimensions of the coil terminal, if a change in direction of the connection is desired, or when five wires are to be connected. This is the most typical bonding method used on our motors.

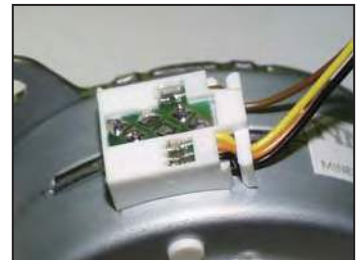

### 2) IDC Method

This a method whereby a pressure welding type connector is attached to the coil terminal of the motor and the lead wire is pressure welded using a special device.

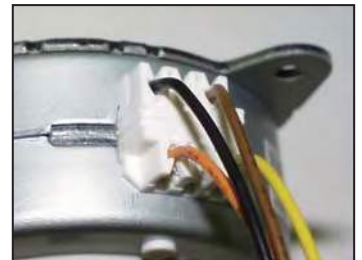

### 3) PCB Connector Method

The connector is attached to the coil terminal of the motor via the PCB, to connect a wire prepared by the customer. In order to reduce total costs, this method has been increasingly used in recent years.



### 4) Pin Terminal Method

In this method, a terminal pin protrudes directly from the coil terminal of the motor. This method is suitable when the customer wishes to directly attach and solder the motor to the PCB, etc. This method is often used for miniature motors with a diameter less than  $\phi 25$ .



### 5) FPC Method

The FPC is directly soldered to the coil terminal of the motor for use. However, costs are disadvantageous where only a small volume is to be handled, or when the FPC is long (optimum length is less than 50mm). This method is therefore most often used for miniature motors with a diameter less than  $\phi 25$ .





## ■ Selection of Gear, Pulley etc.

It is general practice to provide motor shafts along with gears and pulleys attached. In accordance with customer demands, we prepare and attach gears, pulleys, and other necessary parts, before delivery. Of course we are able to provide shafts without these parts attached, but this requires that the customer carry out assembly. In such a case, the customer must ensure that a strong external force is not applied to the motor.

The following explains the gears, pulleys, etc., which we normally use. Please note that we can also provide products that are not listed below. In the case that such products are indeed required, please do not hesitate to contact us for further details. After assessment, we will be able to inform you if it is possible to meet the necessary specifications or not.

### 1) Gears

#### Machined gears

These gears are machined using brass and aluminum, and accuracy is generally to JGMA standard 4, although JGMA 2 is also possible. If special teeth profiles are required, a charge will be made for the initial costs of the hob.

#### Plastic mold gears

These gears are suitable when large production volumes are required, but it is necessary to pay the cost of the mold. Also, if the motor size is larger than PM35, it is necessary to consider whether the metal sleeve is to be insert molded, or knurl processing is to be carried out on the shaft. Consideration must also be given to torque generated and service environment when making settings.

#### Sintered gears

These gears are suitable when large production volumes are required, but it is necessary to pay the cost of the powder mold. Almost all materials are iron and accuracy is generally to JGMA standard 4, although JGMA 2 is also possible.

### 2) Pulleys

#### Machined pulleys

The one without the flange that a brass material and an aluminum material were manufactured can be offered low-cost as well as a gear manufacturing. Still, in case of you need the flange, the one becomes considerably expensive in the one design (A flange is installed a calking the main body of pulley.), while we can install the flange low-cost by you use the other press flange that we have prepared the standard type and the main body of pulley and the flange is pressed fit in shaft. Moreover, when a maker has opened a tooth form, we can prepare and manufacture a hob, while has not opened one, it becomes considerably expensive because you purchase it from a specified maker.

#### Plastic mold pulleys

These pulleys are suitable when large production volumes are required, but it is necessary to pay the cost of the mold. Also, if the motor size exceeds PM35, it is necessary to consider whether the metal sleeve is to be insert molded, or knurl processing is to be carried out on the shaft. Consideration must also be given to torque generated and service environment when making settings. It is not possible to carry out integrated fabrication of both flanges, so the flange on one side has to be fixed mechanically or otherwise.

#### Sintered pulleys

These pulleys are suitable when large production volumes are required, but it is necessary to pay the cost of the powder mold. Almost all materials are iron. Teeth shape and flange dimension is same as plastic mold pulley.

## ■ Choice of Combination of Standard Parts

Any combination of parts made within the range of the products listed on this homepage constitutes a combination of standard parts, and therefore no initial costs will be incurred. We are confident that the products listed here will satisfy any requirements within the general range of use, however we are also able to provide custom-made products, in order to plan overall cost savings for equipment. In such cases, we charge for initial costs incurred in the preparation of dies, and so on. Please assess these costs against the costs of the equipment as a whole, and then inform us of requirements.

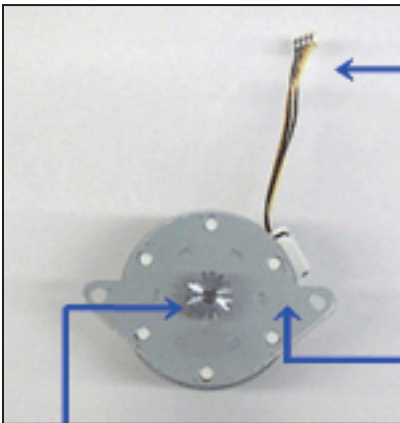

For wire assembly, we use readily available connectors with tinned terminals. The standard length of wires is less than 300mm, and any other lengths desired will require further cost consideration.

The range of front plates listed on the standard dimension page gives standard parts, and if any products outside this range are required, the cost of the die will be charged.

Gear specifications follow the selection of gears mentioned on the standard dimension page, and standard parts have an outer diameter of less than  $\phi 10$ , are less than 10mm in length, and of module 0.3 or more. If these sizes are exceeded, there will be some impact on cost.

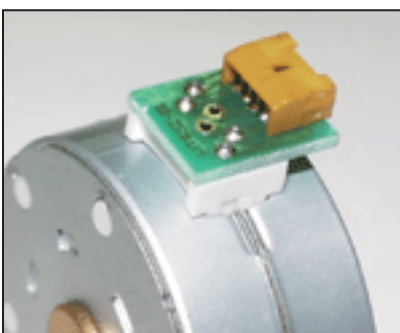

As this will mean a change in the type of connector, direction of connection etc. and in the PCB to which the connector is attached, it is also necessary to manufacture a new PCB. Thus, initial costs will also be incurred for the print, for processing, and for the die. This will not be the case if using connectors or mounting methods recommended by us.

## ■ Description of Standard Dimensions (1)

- Lead wires: in the case of AWG28, lead wires conform to UL1061; in the case of AWG26, they conform to UL1007 and UL1430.
- Apart from discrete wire input connection, we also offer input connection by FPC.
- Please refer to the diagram for a standard front plate.
- Where the gear is attached to the shaft by press fitting, the length of shaft should be selected such that the end of the shaft extends more than 0.5mm beyond the end face of the gear. This reduces problems with press fitting.

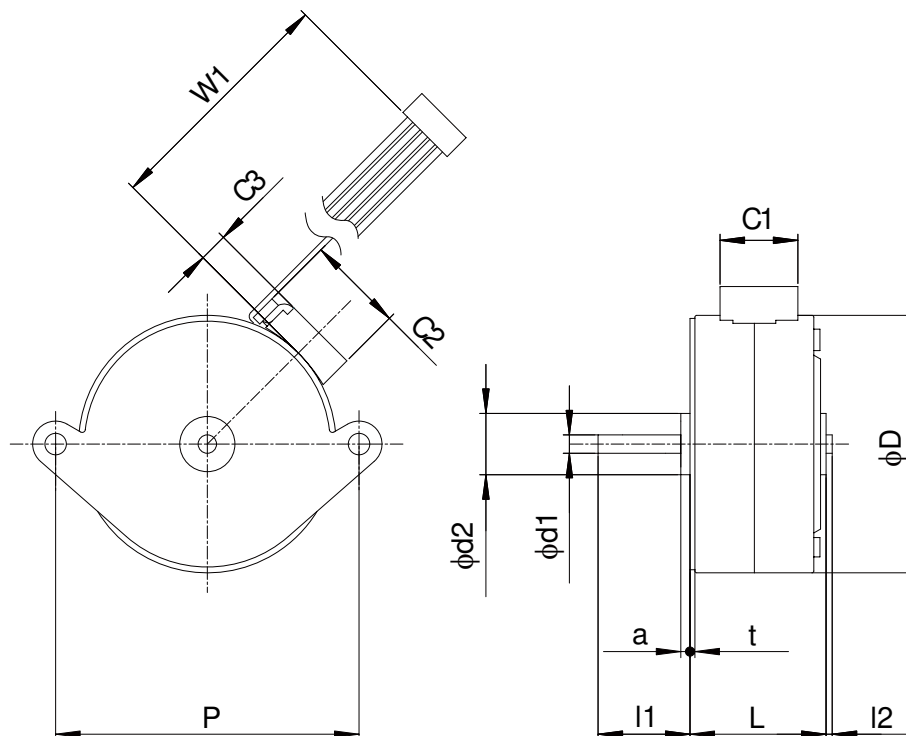

SERIES	D	L MAX	$d1^{+0}_{-0.01}$	d2	a	C1	C2	C3	W1 MIN	t	W(AWG)
PM10S-020	10	10.2	1.5	6	1.2	-	-	-	-	0.5	FPC
PM15S-020	15	12	1.5	6	0.5	-	-	-	-	0.8	FPC
PM20S-020	20	15.5	1.5	6	1.5	11.9	8.4	4.5	50	0.8	28
PM20L-020	20	19.6	1.5	6	1.5	11.9	8.4	4.5	50	0.8	28
PM25S-024,048	25	12.5	2	7	1.5	11.9	8.4	4.5	50	0.8	28
PM25L-024	25	17	2	7	1.5	11.9	8.4	4.5	50	0.8	28
PM35S-024,048	35	15.5	2/3	10	1.5	12.7	15.8	5.5	50	0.8	28
PM35L-024,048	35	22.2	2/3	10	1.5	12.7	15.8	5.5	50	0.8	28
PM42S-048,096,0X1	42	15.5	3	10	1.5	12.7	15.8	5.5	50	0.8	28
PM42M-048	42	20	3	10	1.0	17.4	13	5.5	50	0.8	28
PM42L-048	42	22.2	3	10	1.5	12.7	15.8	5.5	50	0.8	28
PM55L-048,096,0X1	55	25.7	4/6,345	11.13	2.3	12.7	15.8	5.5	50	1.6	28

## Description of Standard Dimensions (2)

SERIES	Front Plate Type	$\theta$									$P \pm 0.2$	H	T	$\alpha$	R	A	Applicable Screw
		30°	45°	60°	75°	90°	105°	120°	135°	150°							
PM10S	PM10S Type					*					15	-	-	-	-	-	M2
PM15S	PM15S Type	*				*				*	20	-	-	-	-		
PM20S,20L	FPH/FPT	*				*				*	28	2.3	M2	18°	3	31	
	FPL		*	*	*	*	*	*	*	*	25						
PM25S,25L	FPH/FPT	*	*	*	*	*	*	*	*	*	32	3	M2.6	15°	3.3	38.6	M2.6
	FPL		*	*	*	*	*	*	*	*					3.5	49	
PM35S,35L	FPH/FPT	*	*	*	*	*	*	*	*	*	42	3.2	M3	15°	3.75	57	M3
	FPL		*	*	*	*	*	*	*	*					49.5	3.5	
PM42S,42L	FPH/FPT	*	*	*	*	*	*	*	*	*	65	4.3	15°	5	75		
PM42M	FPH/FPT	*	*	*	*	*	*	*	*	*				66.7	3.5	-	-
PM55L	FPH/FPT	*	*	*	*	*	*	*	*	*	65	4.3	15°	5	75		
	FPL		*	*	*	*	*	*	*	*	65	3.5	-	-			

The front plate of PM standard type is prepared 3 types as standard type, a FPH is circle hole type of a installing hole, a FPT is tap (female screw) type, a FPL is long hole type. Except for the PM 55 series, all FPT of tap type gave burring (Burring direction is a main body of the motor side).

Please refer to the following table so that a standard collecting of installing hole type and installing angle is different by the series. Please note when you hope the other form and installing angle, the initial cost of the die is generated besides.

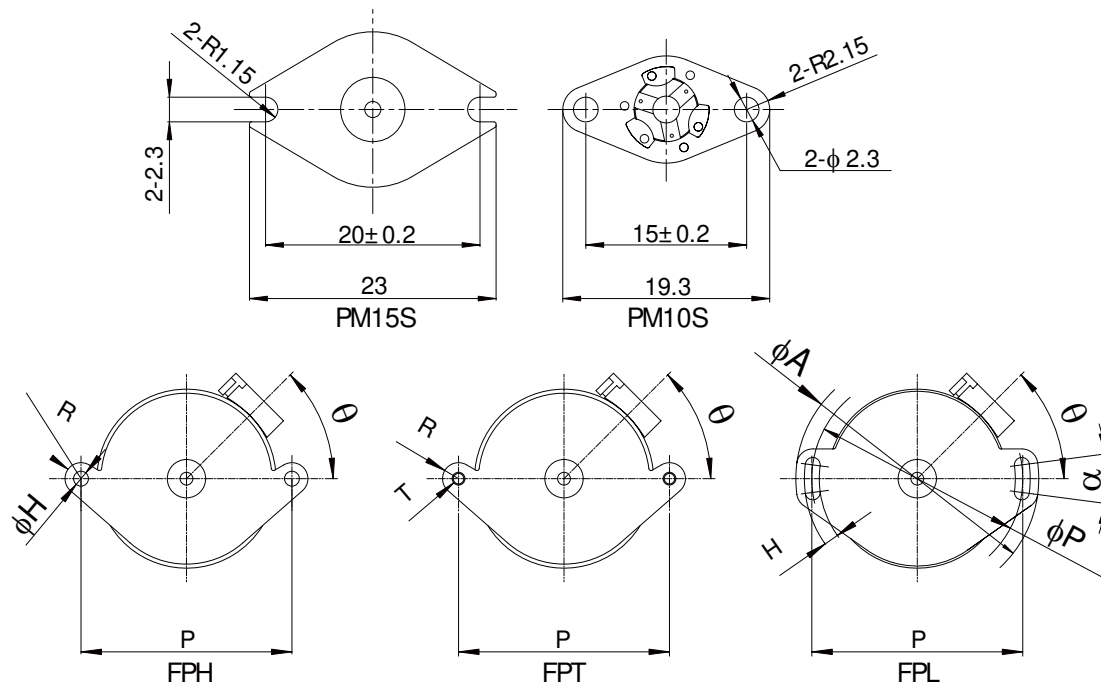

SERIES	$l_1$ ( Standard Shaft Length )																		$l_2$ MAX				
	5	5.5	6	6.5	7	7.5	8	8.5	9	9.5	10	11	12	13	14	15	16	18		20	22	24	
PM10S-020	*	*	*	*	*	*	*	*	*	*	*	*	*	*	*	*	*	*	*	*	*	*	1.0
PM15S-020	*	*	*	*	*	*	*	*	*	*	*	*	*	*	*	*	*	*	*	*	*	*	1.0
PM20S-020	*	*	*	*	*	*	*	*	*	*	*	*	*	*	*	*	*	*	*	*	*	*	1.0
PM20L-020	*	*	*	*	*	*	*	*	*	*	*	*	*	*	*	*	*	*	*	*	*	*	1.0
PM25S-024,048				*	*	*	*	*	*	*	*	*	*	*	*	*	*	*	*	*	*	*	1.0
PM25L-024				*	*	*	*	*	*	*	*	*	*	*	*	*	*	*	*	*	*	*	1.0
PM35S-024,048					*	*	*	*	*	*	*	*	*	*	*	*	*	*	*	*	*	*	1.0
PM35L-024,048					*	*	*	*	*	*	*	*	*	*	*	*	*	*	*	*	*	*	1.0
PM42S-048,096,0X1					*	*	*	*	*	*	*	*	*	*	*	*	*	*	*	*	*	*	1.0
PM42M-048					*	*	*	*	*	*	*	*	*	*	*	*	*	*	*	*	*	*	1.5
PM42L-048					*	*	*	*	*	*	*	*	*	*	*	*	*	*	*	*	*	*	1.0
PM55L-048,096,0X1								*	*	*	*	*	*	*	*	*	*	*	*	*	*	*	1.0

## ■ Drive Circuitry and Wiring Diagram

Show the drive circuitry and standard color of lead wire.

### 1) Drive Circuitry

UNI-POLAR DRIVE

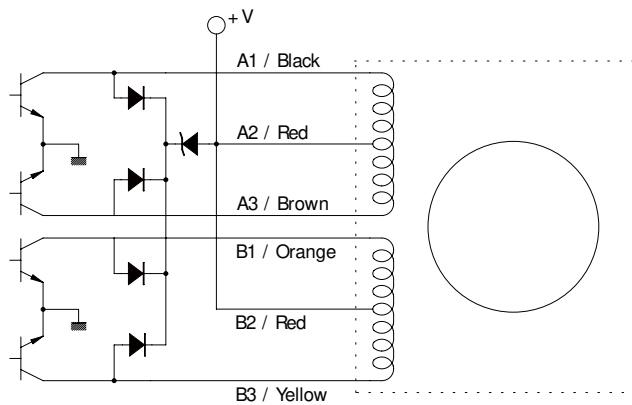

BI-POLAR DRIVE

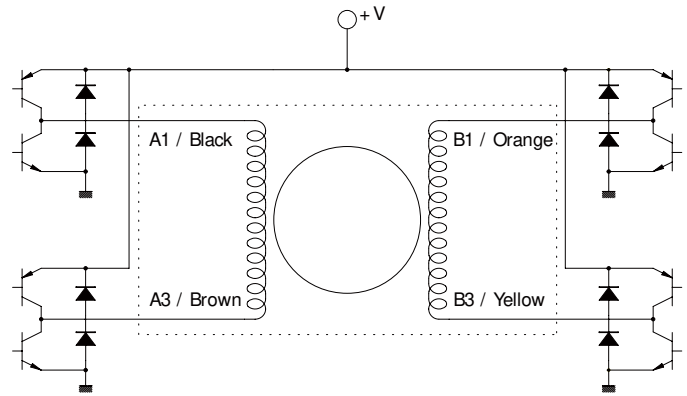

### 2) Switching Sequence ( Using the Drive Circuit Indicated Above )

UNI-POLAR DRIVE

	A1 Black	A3 Brown	B1 Orange	B3 Yellow	A2/B2 Red/Red
1	-			-	+
2	-		-		+
3		-	-		+
4		-		-	+

BI-POLAR DRIVE

	A1 Black	A3 Brown	B1 Orange	B3 Yellow
1	-	+	+	-
2	-	+	-	+
3	+	-	-	+
4	+	-	+	-

The rotation direction is as viewed from the front end.

## ■ Drive Circuitry and Wiring Diagram

### 3) Wiring Diagram ( WIRE HOLDER Method )

#### STANDARD W/H DIRECTION

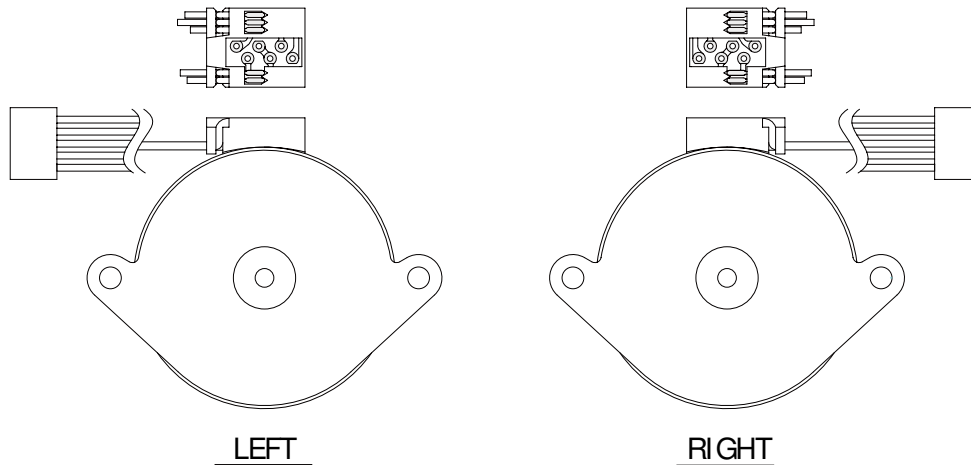

#### Standard Wiring Color

MOTOR	WIRE COLOR	MOTOR	WIRE COLOR
A1	Black	B1	Orange
A2	Red	B2	Red
A3	Brown	B3	Yellow

Please refer to the former page for switching sequence.

#### PM15S

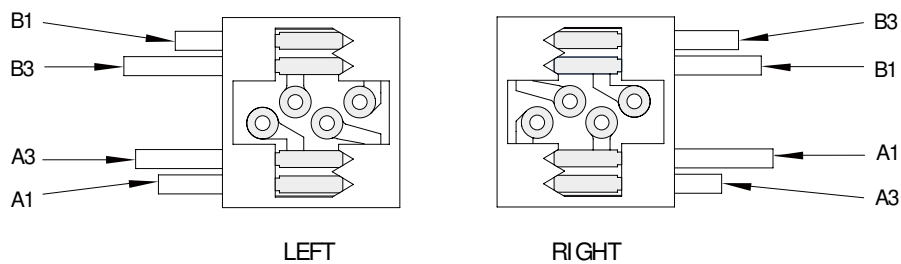

#### PM20, PM25

