

REF. -50 OPT. SCREW
(WHERE APPLICABLE)

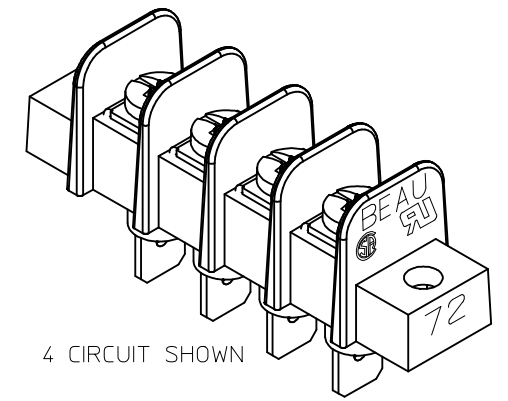

4 CIRCUIT SHOWN

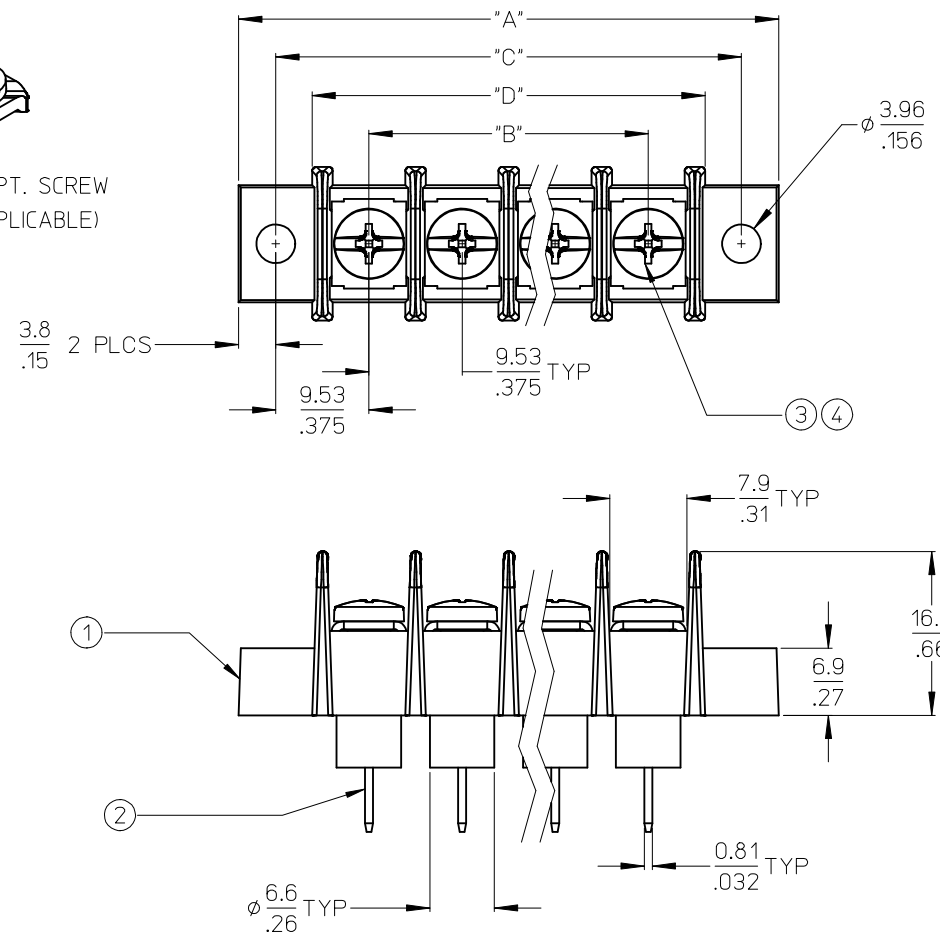
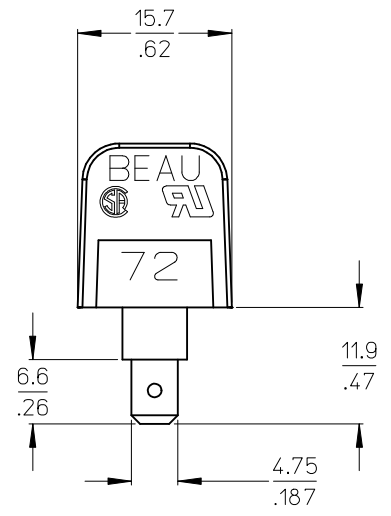

- NOTES:
1. MATERIAL: SEE TABLE
 2. FINISHES: SEE TABLE
 3. "XX" REFERS TO THE QUANTITY OF CIRCUITS.
 4. ROHS COMPLIANT.

ITEM	QTY.	DESCRIPTION	MATERIAL	FINISH
5	XX	SCRW&WSHR, #6-32X.25, PAN, PH/SL (-50 OPT)	STEEL	ZN, CLEAR CHROMATE
4	XX	SCREW, #6-32X.250, BHD, PH/SL (-49 OPT)	BRASS	NICKEL PLATE
3	XX	SCREW, #6-32X.250, BHD, PH/SL (STD.)	STEEL	ZN, CLEAR CHROMATE
2	XX	TERMINAL, FT .187	BRASS	TIN PLATE
1	1	INSULATOR, SR W/SOLID MTG. END	POLYESTER (PBT)	BLACK

RELEASE
EC NO: WNA2009-0702
DRWN: JENC INAS 2009/05/26
CHKD: CYORK 2009/05/27
APPR: JMACNEIL 2009/05/27

QUALITY SYMBOLS
▽=0
▽=0

GENERAL TOLERANCES (UNLESS SPECIFIED)	
mm	INCH
4 PLACES ± ---	± ---
3 PLACES ± ---	± .005
2 PLACES ± 0.13	± .01
1 PLACE ± 0.3	± ---
ANGULAR ± 2 °	

DRAFT WHERE APPLICABLE
MUST REMAIN WITHIN DIMENSIONS

DIMENSION STYLE	
MM/IN	DATE
DRAWN BY	AHIDALGO
DATE	2007/05/28
CHECKED BY	JENC INAS
DATE	2007/05/28
APPROVED BY	JMACNEIL
DATE	2007/05/28

SCALE	DESIGN UNITS	THIRD ANGLE PROJECTION
1:1	INCH	☉
TITLE 9.53/.375 SR BTS ASSY' INSULATED QUICK CONNECT SOLID MOUNTING ENDS		
MATERIAL NO. SEE SHT. 2		
DOCUMENT NO. SD-38721-009		SHEET NO. 1 OF 2
THIS DRAWING CONTAINS INFORMATION THAT IS PROPRIETARY TO MOLEX INCORPORATED AND SHOULD NOT BE USED WITHOUT WRITTEN PERMISSION		

QTY CKTS	DIM "A"		DIM "B"		DIM "C"		DIM "D"		MATERIAL	MATERIAL	MATERIAL
	MM	INCH	MM	INCH	MM	INCH	MM	INCH	# STD. OPT.	# -49 OPT.	# -50 OPT.
2	40.3	1.59	9.53	0.375	28.58	1.125	21.1	0.83	387216602	387216902	387217202
3	49.8	1.96	19.05	0.750	38.10	1.500	30.6	1.21	387216603	387216903	387217203
4	59.3	2.34	28.58	1.125	47.63	1.875	40.2	1.58	387216604	387216904	387217204
5	68.8	2.71	38.10	1.500	57.15	2.250	49.7	1.96	387216605	387216905	387217205
6	78.4	3.09	47.63	1.875	66.68	2.625	59.2	2.33	387216606	387216906	387217206
7	87.9	3.46	57.15	2.250	76.20	3.000	68.8	2.71	387216607	387216907	387217207
8	97.4	3.84	66.68	2.625	85.73	3.375	78.3	3.08	387216608	387216908	387217208
9	106.9	4.21	76.20	3.000	95.25	3.750	87.8	3.46	387216609	387216909	387217209
10	116.5	4.59	85.73	3.375	104.78	4.125	97.3	3.83	387216610	387216910	387217210
11	126.0	4.96	95.25	3.750	114.30	4.500	106.9	4.21	387216611	387216911	387217211
12	135.5	5.34	104.78	4.125	123.83	4.875	116.4	4.58	387216612	387216912	387217212
13	145.0	5.71	114.30	4.500	133.35	5.250	125.9	4.96	387216613	387216913	387217213
14	154.6	6.09	123.83	4.875	142.88	5.625	135.5	5.33	387216614	387216914	387217214
15	164.1	6.46	133.35	5.250	152.40	6.000	145.0	5.71	387216615	387216915	387217215
16	173.6	6.84	142.88	5.625	161.93	6.375	154.5	6.08	387216616	387216916	387217216
17	183.1	7.21	152.40	6.000	171.45	6.750	164.1	6.46	387216617	387216917	387217217
18	192.7	7.59	161.93	6.375	180.98	7.125	173.6	6.83	387216618	387216918	387217218
19	202.2	7.96	171.45	6.750	190.50	7.500	183.1	7.21	387216619	387216919	387217219
20	211.7	8.34	180.98	7.125	200.03	7.875	192.6	7.58	387216620	387216920	387217220
21	221.2	8.71	190.50	7.500	209.55	8.250	202.2	7.96	387216621	387216921	387217221
22	230.8	9.09	200.03	7.875	219.08	8.625	211.7	8.33	387216622	387216922	387217222
23	240.3	9.46	209.55	8.250	228.60	9.000	221.2	8.71	387216623	387216923	387217223
24	249.8	9.84	219.08	8.625	238.13	9.375	230.8	9.08	387216624	387216924	387217224
25	259.3	10.21	228.60	9.000	247.65	9.750	240.3	9.46	387216625	387216925	387217225
26	268.9	10.59	238.13	9.375	257.18	10.125	249.8	9.83	387216626	387216926	387217226

SEE SHEET ONE EC NO: WNA2009-0702 DRAWN: JENCINAS 2009/05/26 CHKD: C'YORK 2009/05/27 APPR: JMACNEIL 2009/05/27	QUALITY SYMBOLS ▽=0 ▽=0	GENERAL TOLERANCES (UNLESS SPECIFIED)		DIMENSION STYLE MM/IN		SCALE 2:1	DESIGN UNITS INCH	THIRD ANGLE PROJECTION
		4 PLACES ± --- ± ---	DRAWN BY AHIDALGO	DATE 2007/05/28	TITLE 9.53/.375 SR BTS ASSY' INSULATED QUICK CONNECT SOLID MOUNTING ENDS			
		3 PLACES ± --- ± .005	CHECKED BY JENCINAS	DATE 2007/05/28				
		2 PLACES ± 0.13 ± .01	APPROVED BY JMACNEIL	DATE 2007/05/28	MOLEX INCORPORATED DOCUMENT NO. SD-38721-009			
1 PLACE ± 0.3 ± ---	MATERIAL NO.	SHEET NO. 2 OF 2						
DRAFT WHERE APPLICABLE MUST REMAIN WITHIN DIMENSIONS				SEE CHART		THIS DRAWING CONTAINS INFORMATION THAT IS PROPRIETARY TO MOLEX INCORPORATED AND SHOULD NOT BE USED WITHOUT WRITTEN PERMISSION		