



3V, Ultra-Low-Power Quadrature Modulator/Demodulator

MAX2450

General Description

The MAX2450 combines a quadrature modulator and quadrature demodulator with a supporting oscillator and divide-by-8 prescaler on a monolithic IC. It operates from a single +3V supply and draws only 5.9mA. The demodulator accepts an amplified and filtered IF signal in the 35MHz to 80MHz range, and demodulates it into I and Q baseband signals with 51dB of voltage conversion gain. The IF input is terminated with a 400Ω thin-film resistor for matching to an external IF filter. The baseband outputs are fully differential and have 1.2Vp-p signal swings. The modulator accepts differential I and Q baseband signals with amplitudes up to 1.35Vp-p and bandwidths to 15MHz, and produces a differential IF signal in the 35MHz to 80MHz range.

Pulling the CMOS-compatible ENABLE pin low shuts down the MAX2450 and reduces the supply current to less than 1μA. To minimize spurious feedback, the MAX2450's internal oscillator is set at twice the IF via external tuning components. The oscillator and associated phase shifters produce differential signals exhibiting low amplitude and phase imbalance, yielding modulator sideband rejection of 38dB. The MAX2450 comes in a QSOP package.

Applications

- Digital Cordless Phones
- GSM and North American Cellular Phones
- Wireless LANs
- Digital Communications
- Two-Way Pagers

Pin Configuration

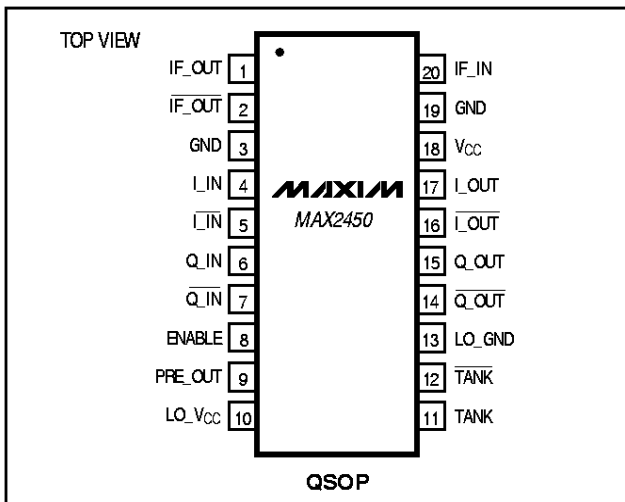

Features

- ◆ Combines Quadrature Modulator and Demodulator
- ◆ Integrated Quadrature Phase Shifters
- ◆ On-Chip Oscillator (Requires External Tuning Circuit)
- ◆ On-Chip Divide-by-8 Prescaler
- ◆ Modulator Input Bandwidth Up to 15MHz
- ◆ Demodulator Output Bandwidth Up to 9MHz
- ◆ 51dB Demodulator Voltage Conversion Gain
- ◆ CMOS-Compatible Enable
- ◆ 5.9mA Operating Supply Current
1μA Shutdown Supply Current

Ordering Information

PART	TEMP. RANGE	PIN-PACKAGE
MAX2450CEP	0°C to +70°C	20 QSOP

Functional Diagram

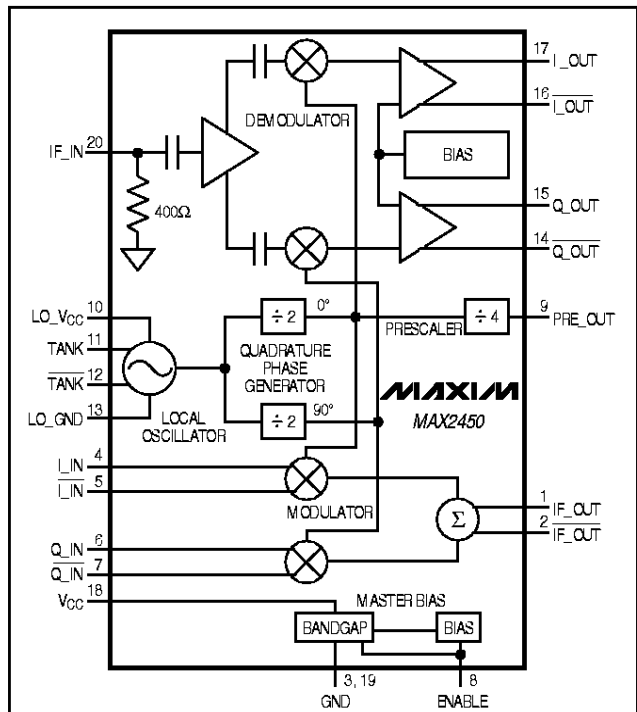

3V, Ultra-Low-Power Quadrature Modulator/Demodulator

ABSOLUTE MAXIMUM RATINGS

V _{CC} , LO_V _{CC} to GND.....	-0.3V to +4.5V	Continuous Power Dissipation (T _A = +70°C)	
ENABLE, TANK, $\overline{\text{TANK}}$, I _{IN} , $\overline{\text{I}}_{\text{IN}}$, Q _{IN} , $\overline{\text{Q}}_{\text{IN}}$ to GND.....	-0.3V to (V _{CC} + 0.3V)	QSOP (derate 9.1mW/°C above +70°C).....	727mW
IF_IN to GND.....	-0.3V to +1.5V	Operating Temperature Range.....	0°C to +70°C
		Storage Temperature Range.....	-65°C to +165°C
		Lead Temperature (soldering, 10sec).....	+300°C

Stresses beyond those listed under "Absolute Maximum Ratings" may cause permanent damage to the device. These are stress ratings only, and functional operation of the device at these or any other conditions beyond those indicated in the operational sections of the specifications is not implied. Exposure to absolute maximum rating conditions for extended periods may affect device reliability.

DC ELECTRICAL CHARACTERISTICS

(V_{CC} = LO_V_{CC} = TANK = 2.7V to 3.3V, ENABLE = V_{CC} - 0.4, GND = LO_GND = 0V, I_{IN} = $\overline{\text{I}}_{\text{IN}}$ = Q_{IN} = $\overline{\text{Q}}_{\text{IN}}$ = IF_IN = TANK = OPEN, T_A = 0°C to +70°C, unless otherwise noted.)

PARAMETER	SYMBOL	CONDITIONS	MIN	TYP	MAX	UNITS
Supply Voltage Range	V _{CC} , LO_V _{CC}		2.7		3.3	V
Supply Current	I _{CC(ON)}			5.9	8.2	mA
Shutdown Supply Current	I _{CC(OFF)}	ENABLE = 0.4V		2	20	μA
Enable/Disable Time	t _{ON/OFF}			10		μs
ENABLE Bias Current	I _{EN}	ENABLE = V _{CC}		1	3	μA
ENABLE High Voltage	V _{ENH}		V _{CC} - 0.4			V
ENABLE Low Voltage	V _{ENL}				0.4	V
I _{IN} , $\overline{\text{I}}_{\text{IN}}$, Q _{IN} , $\overline{\text{Q}}_{\text{IN}}$ Self-Bias DC Voltage Level	V _{I_{IN}/$\overline{\text{I}}_{\text{IN}}$} , V _{Q_{IN}/$\overline{\text{Q}}_{\text{IN}}$}		1.25	1.5	1.75	V
Modulator Differential Input Impedance	Z _{I_{IN}/$\overline{\text{I}}_{\text{IN}}$} , Z _{Q_{IN}/$\overline{\text{Q}}_{\text{IN}}$}		35	44		kΩ
IF_OUT, $\overline{\text{IF}}_{\text{OUT}}$ DC Bias Voltage	V _{IF_OUT/$\overline{\text{IF}}_{\text{OUT}}$}			V _{CC} - 1.5		V
Demodulator IF Input Impedance	Z _{IF_IN}		320	400	480	Ω
Demodulator I and Q Baseband DC Offset				±11	±50	mV
I_OUT, $\overline{\text{I}}_{\text{OUT}}$, Q_OUT, $\overline{\text{Q}}_{\text{OUT}}$ DC Bias Voltage Level	V _{I_OUT/$\overline{\text{I}}_{\text{OUT}}$} , V _{Q_OUT/$\overline{\text{Q}}_{\text{OUT}}$}			1.2		V

AC ELECTRICAL CHARACTERISTICS

(MAX2450 EV kit, V_{CC} = LO_V_{CC} = ENABLE = 3.0V, f_{LO} = 140MHz, f_{I_{IN}/ $\overline{\text{I}}_{\text{IN}}$} = f_{Q_{IN}/ $\overline{\text{Q}}_{\text{IN}}$} = 600kHz, V_{I_{IN}/ $\overline{\text{I}}_{\text{IN}}$} = V_{Q_{IN}/ $\overline{\text{Q}}_{\text{IN}}$} = 1.2V_{p-p}, f_{IF_IN} = 70.1MHz, V_{IF_IN} = 2.82mV_{p-p}, T_A = +25°C, unless otherwise noted.)

PARAMETER	SYMBOL	CONDITIONS	MIN	TYP	MAX	UNITS
DEMODULATOR						
I and Q Amplitude Balance				< ±0.45		dB
I and Q Phase Accuracy				< ±1.3		degrees
Voltage Conversion Gain				51		dB
Allowable I and Q Voltage Swing		(Note 1)			1.35	V _{p-p}
Noise Figure	NF			18		dB
I and Q IM3 Level	IM _{3/I/Q}	(Note 2)		-44		dBc
I and Q IM5 Level	IM _{5/I/Q}	(Note 2)		-60		dBc
I and Q Signal 3dB Bandwidth	BW _{DEM}			9		MHz
Oscillator Frequency Range	f _{LO}	(Notes 1, 3)	70		160	MHz
LO Phase Noise		10kHz offset		-80		dBc/Hz
PRE_OUT Output Voltage	V _{PRE_OUT}	R _L = 10kΩ, C _L < 6pF		0.35		V _{p-p}
PRE_OUT Slew Rate	SR _{PRE_OUT}	R _L = 10kΩ, C _L < 6pF, rising edge		60		V/μs

3V, Ultra-Low-Power Quadrature Modulator/Demodulator

MAX2450

AC ELECTRICAL CHARACTERISTICS (continued)

(MAX2450 EV kit, $V_{CC} = LO_V_{CC} = ENABLE = 3.0V$, $f_{LO} = 140MHz$, $f_{I_IN/I_IN} = f_{Q_IN/Q_IN} = 600kHz$, $V_{I_IN/I_IN} = V_{Q_IN/Q_IN} = 1.2V_{p-p}$, $f_{IF_IN} = 70.1MHz$, $V_{IF_IN} = 2.82mV_{p-p}$, $T_A = +25^{\circ}C$, unless otherwise noted.)

PARAMETER	SYMBOL	CONDITIONS	MIN	TYP	MAX	UNITS
MODULATOR						
Allowable Differential Input Voltage	$\frac{V_{I_IN/I_IN}}{V_{Q_IN/Q_IN}}$	(Note 1)			1.35	V_{p-p}
Input Common-Mode Voltage Range			1.25		1.75	V
I and Q Signal 3dB Bandwidth	BW_{MOD}			15		MHz
IF Differential Output Voltage	V_{IF_OUT/IF_OUT}	$V_{I_IN/I_IN} = V_{Q_IN/Q_IN} = 1.2V_{p-p}$, $R_L = 200k\Omega$ differential, $C_L < 5pF$ differential		65		mV_{p-p}
IF Output IM3 Level	$IM3_{IF}$	$V_{I_IN/I_IN} = 1.35V_{p-p}$ composite (Note 4)		-60		dBc
IF Output IM5 Level	$IM5_{IF}$	$V_{I_IN/I_IN} = 1.35V_{p-p}$ composite (Note 4)		-60		dBc
Sideband Rejection				38		dBc
Carrier Suppression at Modulator Output				-36		dBc

Note 1: Guaranteed by design, not tested.

Note 2: $f_{IF_IN} = 2$ tones at 70.10MHz and 70.11MHz. $V_{IF_IN} = 1.41mV_{p-p}$ per tone.

Note 3: The frequency range can be extended in either direction, but has not been characterized. At higher frequencies, the modulator IF output amplitude may decrease and distortions may increase.

Note 4: Q_IN/Q_IN ports are terminated. $f_{I_IN/I_IN} = 2$ tones at 550kHz and 600kHz.

Typical Operating Characteristics

(MAX2450 EV kit, $V_{CC} = LO_V_{CC} = ENABLE = 3.0V$, $f_{LO} = 140MHz$, $f_{I_IN/I_IN} = f_{Q_IN/Q_IN} = 600kHz$, $V_{I_IN/I_IN} = V_{Q_IN/Q_IN} = 1.2V_{p-p}$, $f_{IF_IN} = 70.1MHz$, $V_{IF_IN} = 2.82mV_{p-p}$, $T_A = +25^{\circ}C$, unless otherwise noted.)

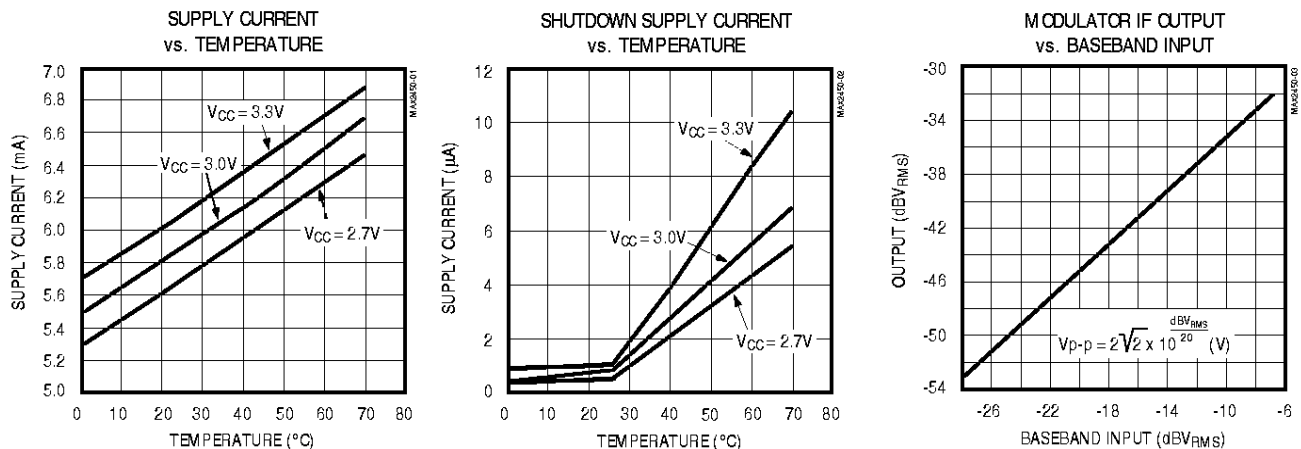

3V, Ultra-Low-Power Quadrature Modulator/Demodulator

Typical Operating Characteristics (continued)

(MAX2450 EV kit, $V_{CC} = LO_V_{CC} = ENABLE = 3.0V$, $f_{LO} = 140MHz$, $f_{I_IN/\bar{I}_IN} = f_{Q_IN/\bar{Q}_IN} = 600kHz$, $V_{I_IN/\bar{I}_IN} = V_{Q_IN/\bar{Q}_IN} = 1.2Vp-p$, $f_{IF_IN} = 70.1MHz$, $V_{IF_IN} = 2.82mVp-p$, $T_A = +25^\circ C$, unless otherwise noted.)

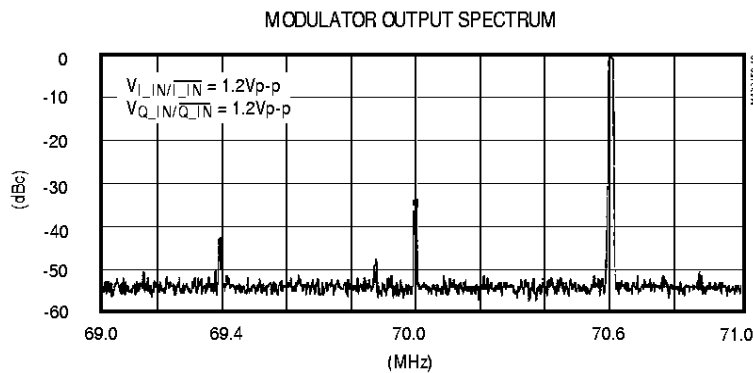
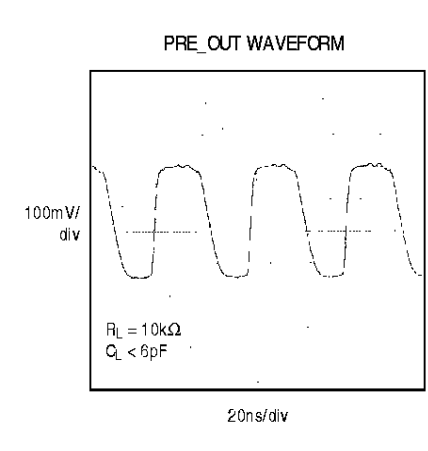
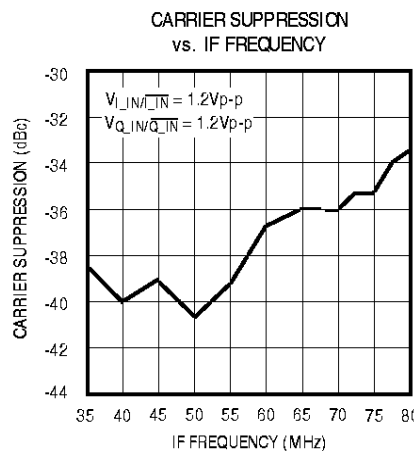
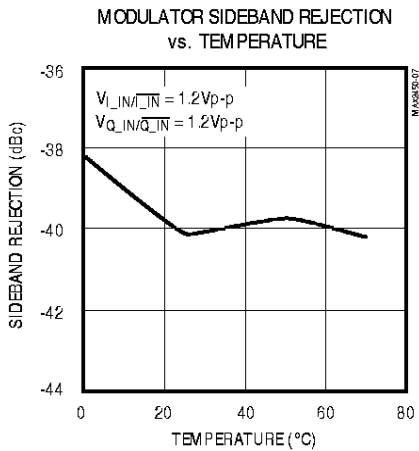
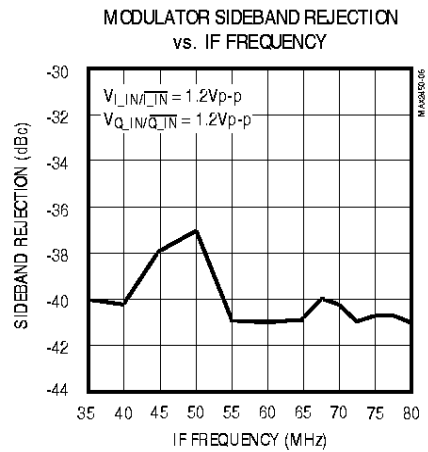
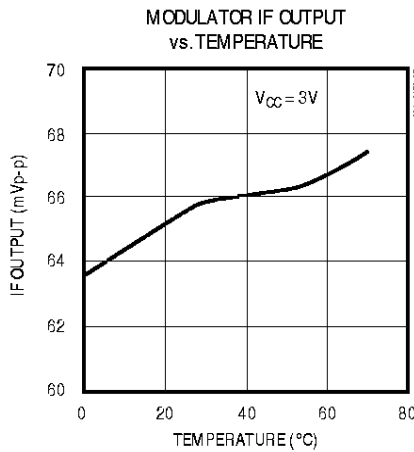
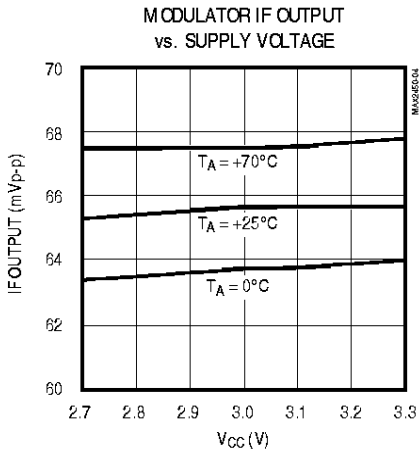

3V, Ultra-Low-Power Quadrature Modulator/Demodulator

MAX2450

Typical Operating Characteristics (continued)

(MAX2450 EV kit, $V_{CC} = LO_V_{CC} = ENABLE = 3.0V$, $f_{LO} = 140MHz$, $f_{I_{IN}/I_{IN}} = f_{Q_{IN}/Q_{IN}} = 600kHz$, $V_{I_{IN}/I_{IN}} = V_{Q_{IN}/Q_{IN}} = 1.2Vp-p$, $f_{IF_IN} = 70.1MHz$, $V_{IF_IN} = 2.82mVp-p$, $T_A = +25^\circ C$, unless otherwise noted.)

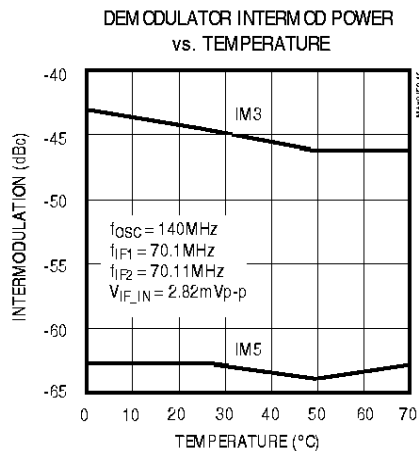
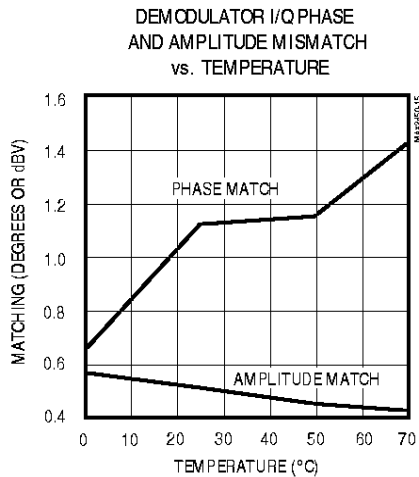
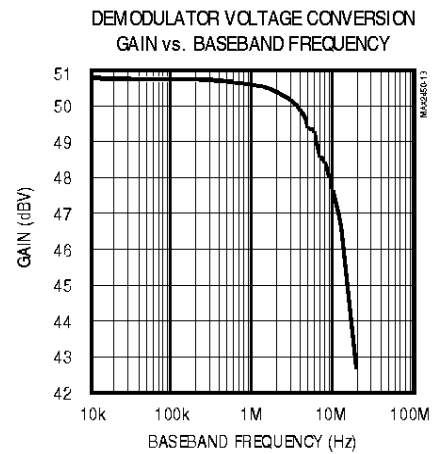
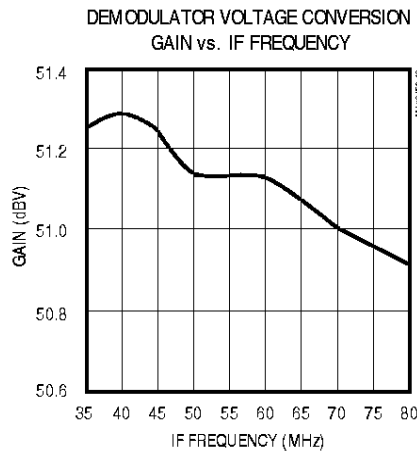
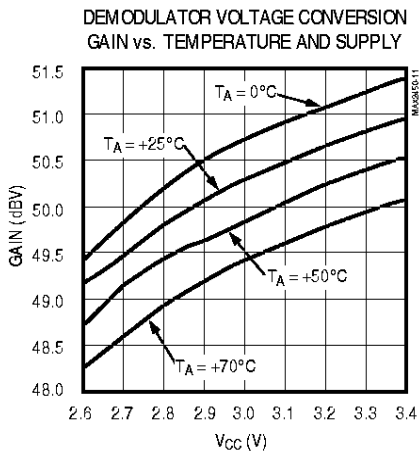

3V, Ultra-Low-Power Quadrature Modulator/Demodulator

Pin Description

PIN	NAME	FUNCTION
1	IF_OUT	Modulator IF Output
2	$\overline{\text{IF_OUT}}$	Modulator IF Inverting Output
3, 19	GND	Ground
4	I_IN	Baseband Inphase Input
5	$\overline{\text{I_IN}}$	Baseband Inphase Inverting Input
6	Q_IN	Baseband Quadrature Input
7	$\overline{\text{Q_IN}}$	Baseband Quadrature Inverting Input
8	ENABLE	Enable Control, active high
9	PRE_OUT	Local-Oscillator, Divide-by-8, Prescaled Output
10	LO_VCC	Local-Oscillator Supply. Bypass separately from VCC.
11	TANK	Local-Oscillator Resonant Tank Input (Figure 4)
12	$\overline{\text{TANK}}$	Local-Oscillator Resonant Tank Inverting Input (Figure 4)
13	LO_GND	Local-Oscillator Ground
14	$\overline{\text{Q_OUT}}$	Demodulator Quadrature Inverting Output
15	Q_OUT	Demodulator Quadrature Output
16	$\overline{\text{I_OUT}}$	Demodulator Inphase Inverting Output
17	I_OUT	Demodulator Inphase Output
18	VCC	Modulator and Demodulator Supply
20	IF_IN	Demodulator IF Input

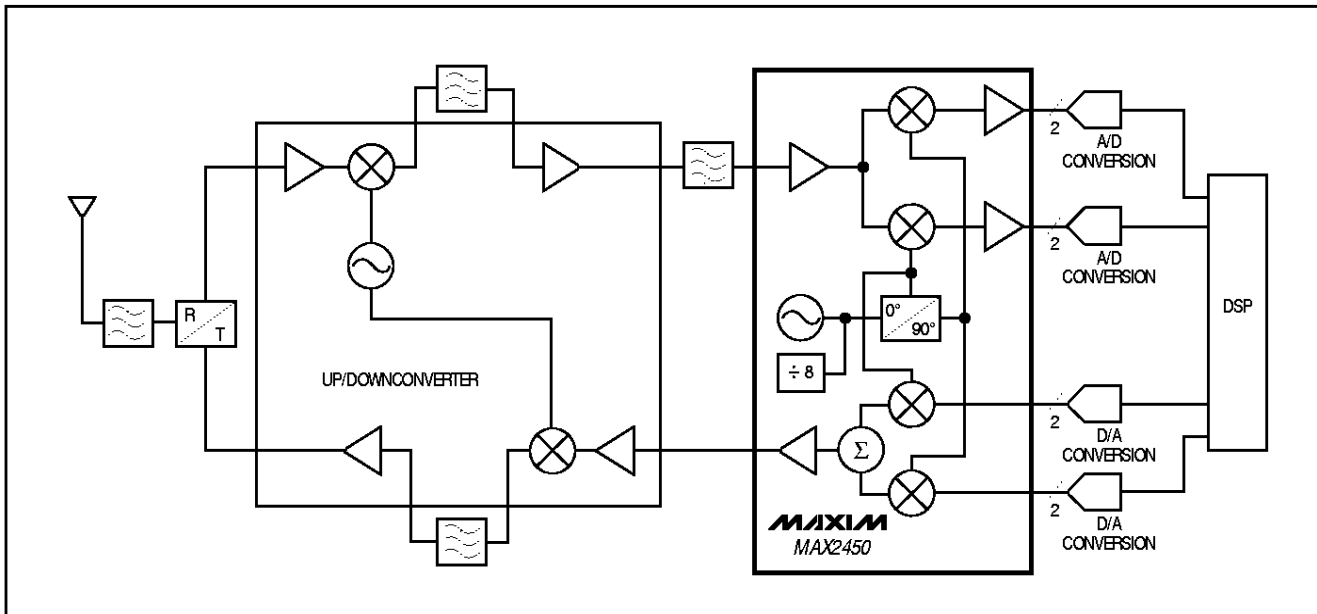

Figure 1. Typical Application Block Diagram

3V, Ultra-Low-Power Quadrature Modulator/Demodulator

MAX2450

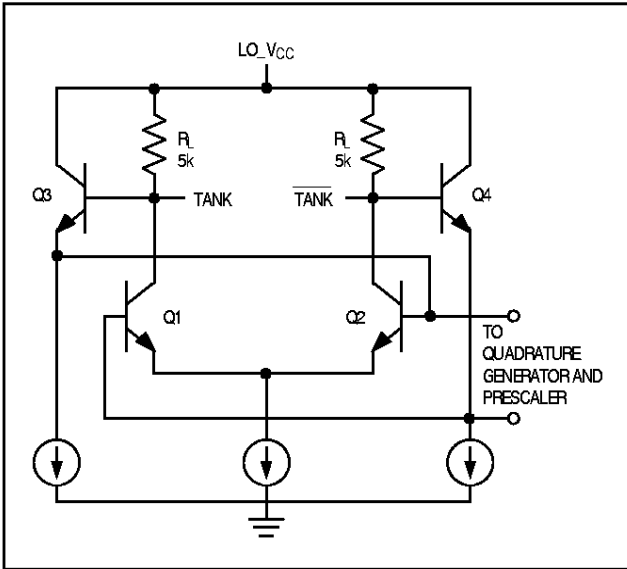

Figure 2. Local-Oscillator Equivalent Circuit

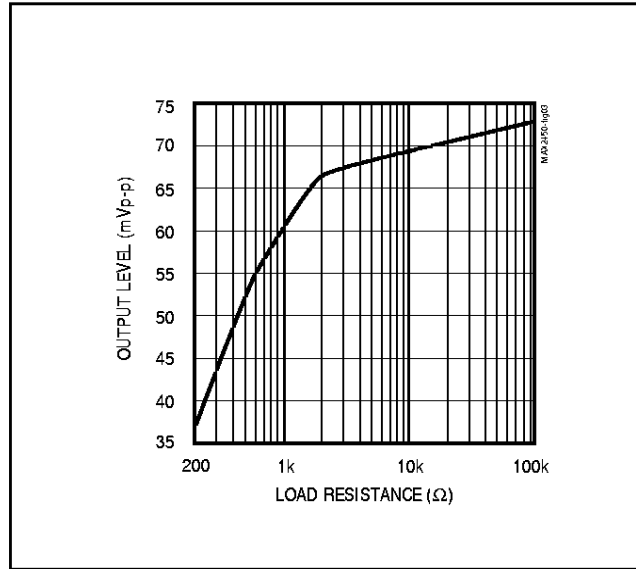

Figure 3. Modulator Output Level vs. Load Resistance

Detailed Description

The following sections describe each of the functional blocks shown in the *Functional Diagram*. They also refer to the Typical Application Block Diagram (Figure 1).

Demodulator

The demodulator contains a single-ended-to-differential converter, two Gilbert-cell multipliers, and two fixed gain stages. The IF signal should be AC coupled into IF_IN. Internally, IF_IN is terminated with a 400Ω resistor to GND and provides a gain of 14dB. This amplified IF signal is fed into the I and Q mixers for demodulation. The multipliers mix the IF signal with the quadrature LO signals, resulting in baseband I and Q signals. The conversion gain of the multipliers is 15dB. These signals are further amplified by 21dB by the baseband amplifiers. The baseband I and Q amplifier chains are DC coupled.

Local Oscillator

The local-oscillator section is formed by an emitter-coupled differential pair. Figure 2 shows the equivalent local-oscillator circuit schematic. An external LC resonant tank determines the oscillation frequency, and the Q of this resonant tank affects the oscillator phase noise. The oscillation frequency is twice the IF frequency, so that the quadrature phase generator can use two latches to generate precise quadrature signals.

The oscillator may be overdriven by an external source. The source should be AC coupled into TANK/TANK,

and should provide 200mVp-p levels. A choke (typically 2.2μH) is required between TANK and TANK. Differential input impedance at TANK/TANK is 10kΩ. For single-ended drive, connect an AC bypass capacitor (1000pF) from TANK to GND, and AC couple TANK to the source.

Quadrature Phase Generator

The quadrature phase generator uses two latches to divide the local-oscillator frequency by two, and generates two precise quadrature signals. Internal limiting amplifiers shape the signals to approximate square waves to drive the Gilbert-cell mixers. The inphase signal (at half the local-oscillator frequency) is further divided by four for the prescaler output.

Prescaler

The prescaler output, PRE_OUT, is buffered and swings typically 0.35Vp-p with a 10kΩ and 6pF load. It can be AC-coupled to the input of a frequency synthesizer.

Modulator

The modulator accepts I and Q differential baseband signals up to 1.35Vp-p with frequencies up to 15MHz, and upconverts them to the IF frequency. Since these inputs are biased internally at around 1.5V, I and Q signals should be capacitively coupled into these high-impedance ports (the differential input impedance is approximately 44kΩ). The self-bias design yields very low on-chip offset, resulting in excellent carrier sup-

3V, Ultra-Low-Power Quadrature Modulator/Demodulator

pression. Alternatively, a differential DAC may be connected without AC coupling, as long as a common-mode voltage range of 1.25V to 1.75V is maintained. For single-ended drive, connect $\overline{I_IN}$ and $\overline{Q_IN}$ via AC-coupling capacitors (0.1µF) to GND.

The IF output is designed to drive a high impedance (> 20kΩ), such as an IF buffer or an upconverter mixer. $\overline{IF_OUT}/\overline{IF_OUT}$ must be AC coupled to the load. Impedances as low as 200Ω can be driven with a decrease in output amplitude (Figure 3). To drive a single-ended load, AC couple and terminate $\overline{IF_OUT}$ with a resistive load equal to the load at $\overline{IF_OUT}$.

Master Bias

During normal operation, ENABLE should remain above $V_{CC} - 0.4V$. Pulling the ENABLE input low shuts off the master bias and reduces the circuit current to less than 2µA. The master bias section includes a bandgap reference generator and a PTAT (Proportional To Absolute Temperature) current generator.

Applications Information

Figure 4 shows the implementation of a resonant tank circuit. The inductor, two capacitors, and a dual varactor form the oscillator's resonant circuit. In Figure 4, the oscillator frequency ranges from 130MHz to 160MHz.

To ensure reliable start-up, the inductor is directly connected across the local oscillator's tank ports. The two 33pF capacitors affect the Q of the resonant circuit. Other values may be chosen to meet individual application requirements. Use the following formula to determine the oscillation frequency:

$$f_o = \frac{1}{2\pi\sqrt{L_{EQ}C_{EQ}}}$$

where

$$C_{EQ} = \frac{1}{\frac{1}{C_1} + \frac{1}{C_2} + \frac{2}{C_{VAR}}} + C_{STRAY}$$

and

$$L_{EQ} = L + L_{STRAY}$$

where C_{STRAY} = parasitic capacitance and L_{STRAY} = parasitic inductance.

To alter the oscillation frequency range, change the inductance, the capacitance, or both. For best phase-noise performance keep the Q of the resonant tank as high as possible:

$$Q = R_{EQ} \sqrt{\frac{C_{EQ}}{L_{EQ}}}$$

where $R_{EQ} \approx 10k\Omega$ (Figure 2).

The oscillation frequency can be changed by altering the control voltage, V_{CTRL} .

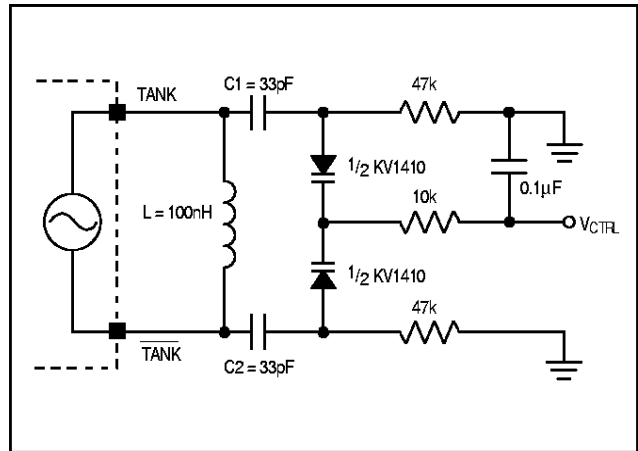

Figure 4. Typical Resonant Tank Circuit

Maxim cannot assume responsibility for use of any circuitry other than circuitry entirely embodied in a Maxim product. No circuit patent licenses are implied. Maxim reserves the right to change the circuitry and specifications without notice at any time.