

CONTROL SIGNATURE:

WIRING DIAGRAM

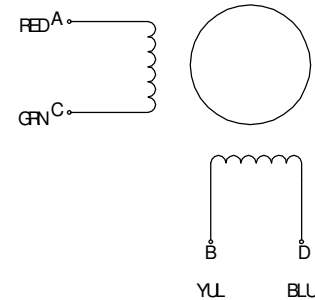

THE INFORMATION CONTAINED IN THIS DRAWING IS CONFIDENTIAL. COPYRIGHT

| COMMON RATEING | | SPECIVICATIONS | |
|-----------------------|---------------------|----------------|------------------|
| STEP ANGLE | $1.8^\circ \pm 5\%$ | VOLTAGE | 12V |
| PHASES | 2 | CURRENT | 0.33A |
| INSULATION RESISTANCE | 100Mohm(500V DC) | INDUCTANCE | $46 \pm 20\%$ Mh |
| CLASS OF INSULATION | B | RESISTANCE | $34 \pm 10\%$ |
| WEIGHT | 0.20Kg | HOLDING TORQUE | 0.23N.M |

| | | |
|----------------|------|----|
| SCALE | UNIT | mm |
| | SIZE | A4 |
| DRAWN XUHEZHAC | | |
| 20090307 | | |
| CHECKED | | |
| APPROVED | | |

| | | | |
|------------------------|------|-----------------------|--------|
| A | | 1ST ISSUE | 090327 |
| REV. | EPO# | DETAILS | DATE |
| UNSPECIFIED TOLERANCE: | | MERCURY MOTOR | |
| MATERIAL | | TITLE | |
| | | SM-42BYG011-25 | |
| FINISH | | SHEET 1 OF 1 | REV A |
| | | DWG.NO. | |
| | | SM-42BYG011-25-090327 | |