

THIS DRAWING IS UNPUBLISHED.
 RELEASED FOR PUBLICATION
 COPYRIGHT BY TYCO ELECTRONICS CORPORATION. ALL RIGHTS RESERVED.

LOC		DIST		REVISIONS			
#	REV	DATE	BY	APPD	DESCRIPTION	DATE	BY
GP	00						
G		27FEB01	MM	JR	REV PER EC 051D-0134-00		

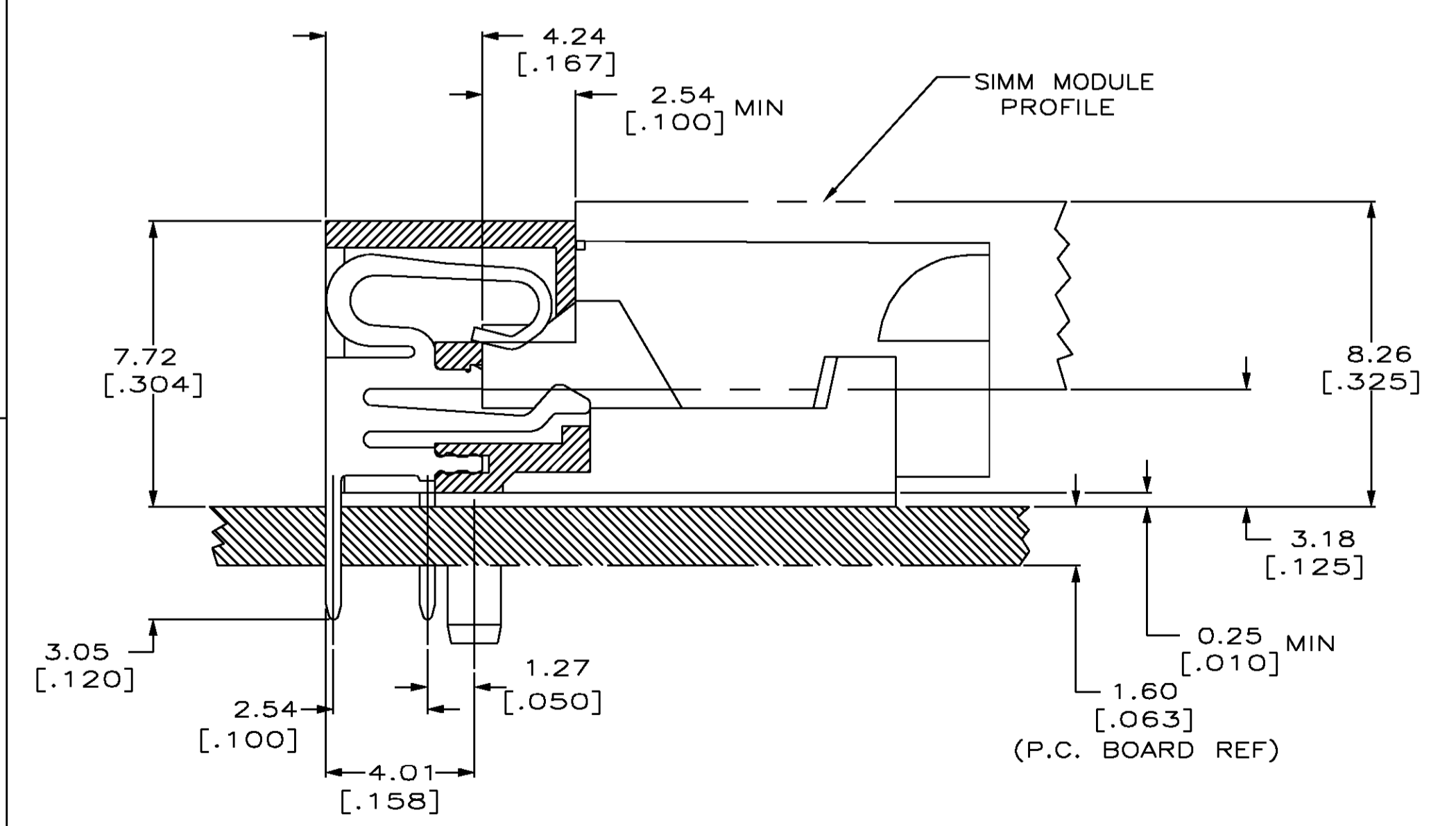
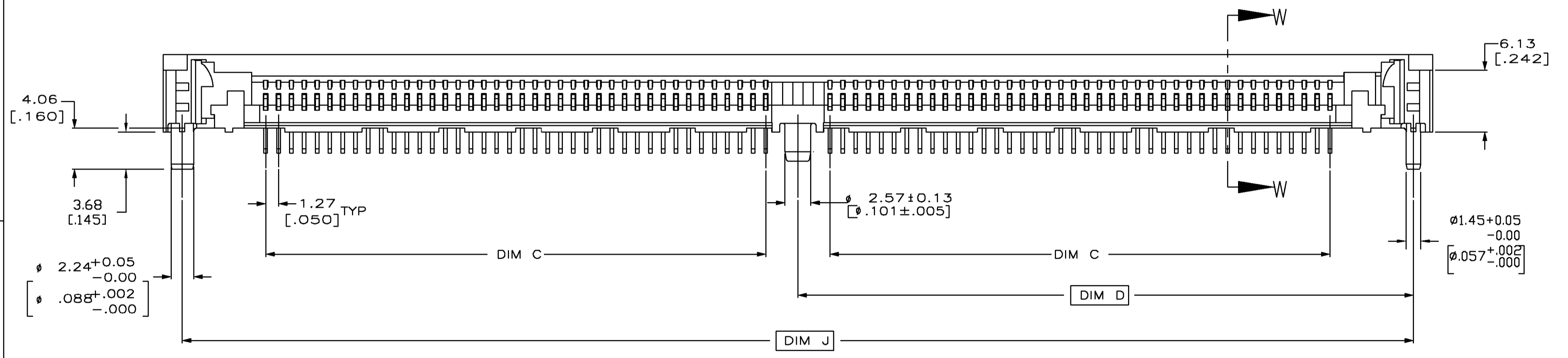
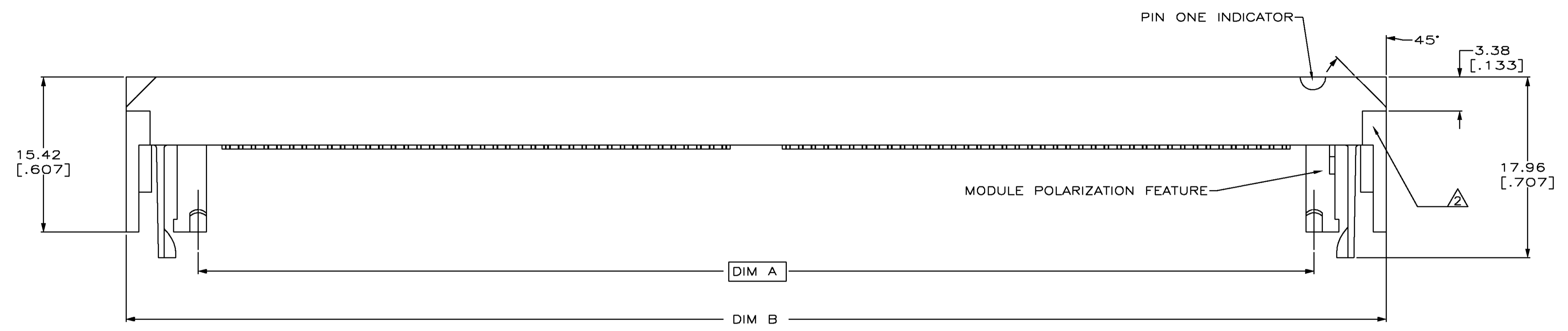

DIMENSIONS:		TOLERANCES (UNLESS OTHERWISE SPECIFIED):		APPROVED:		NAME:	
0 PLC	± .005	1 PLC	± .005	R. TALLEY		7-25-90	
1 PLC	± .005	2 PLC	± .005	-		-	
3 PLC	± .010	3 PLC	± .010	-		-	
4 PLC	± .010	4 PLC	± .010	-		-	
ANGLES:	± .005	-		-		-	
MATERIAL:	HSG:GLASS REINF	FINISH:	-	WEIGHT:	-	SIZE:	A1
CUSTOMER DRAWING				CAGE CODE:	00779	DRAWING NO:	382481
				SCALE:	4:1	SHEET:	1 OF 2

REVISONS		DATE	BY	APPD
GP	00			
DESCRIPTION				
SEE SHT 1				

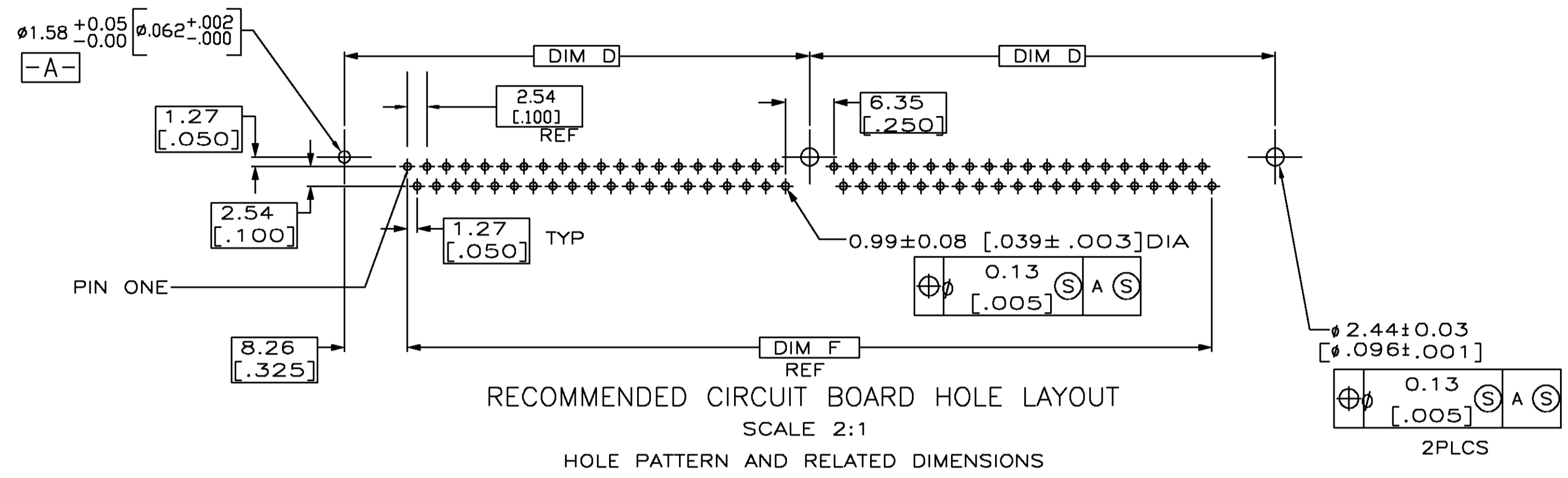

△ FOR OPTIMUM PERFORMANCE, CONTACT PAD PLATING SHOULD BE SMOOTH AND FLAT. COPPER CONTACT PADS ARE TO BE OVERPLATED WITH 0.00127[.000050] MIN THK NICKEL FOLLOWED WITH 0.00101[.000040] MIN THK GOLD PLATING.

△ FEATURES AT EACH END ALIGN CONNECTOR FOR PROPER PLACEMENT WHEN USING ROBOTIC INSERTION.

△ CONTACT MATING AREA:
 0.00076 [.000030] MIN THICK GOLD.
 SOLDER TAIL:
 0.00381 [.000150] MIN THK TIN-LEAD.
 UNDERPLATE:
 0.00127 [.000050] MIN THK NICKEL OVER ENTIRE CONTACT.

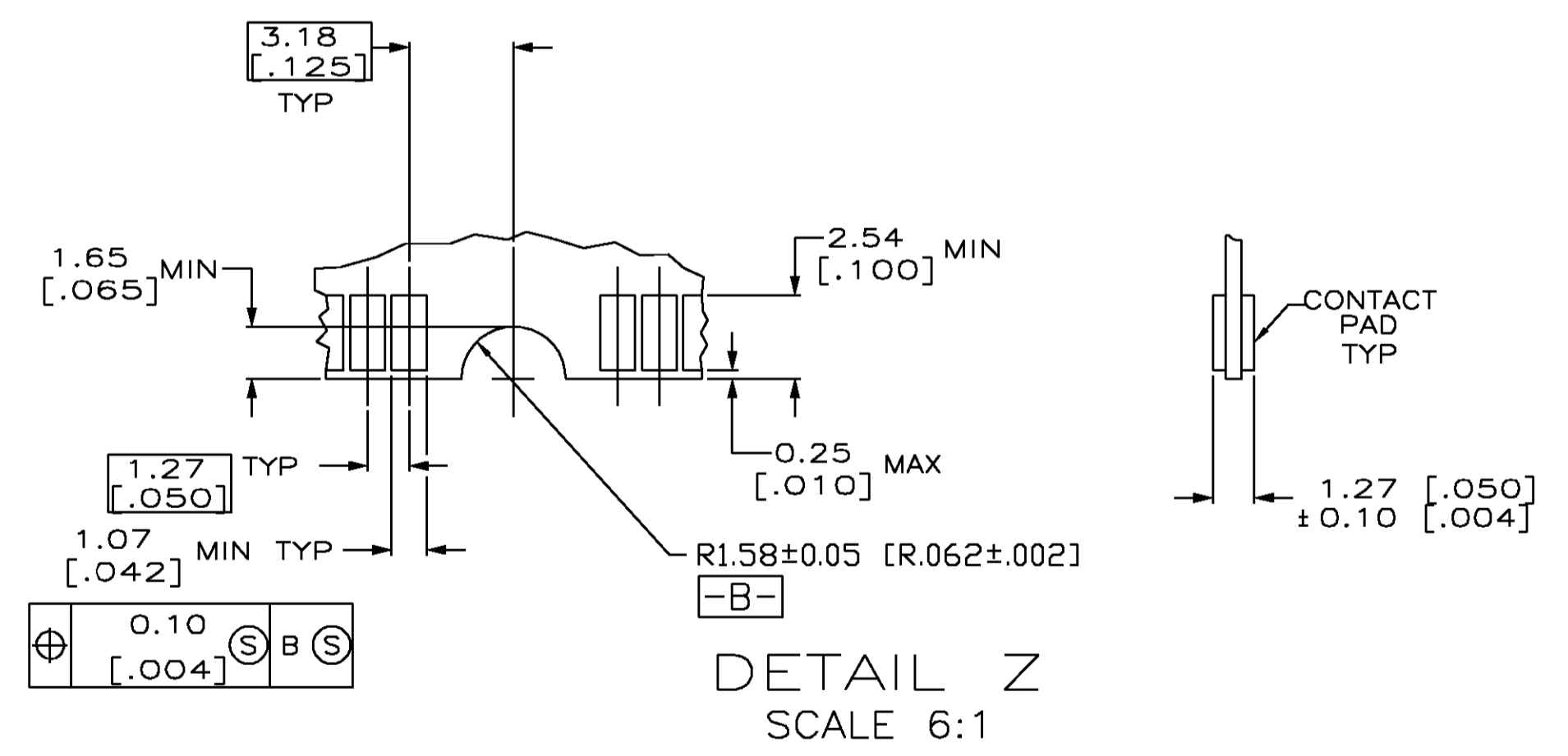
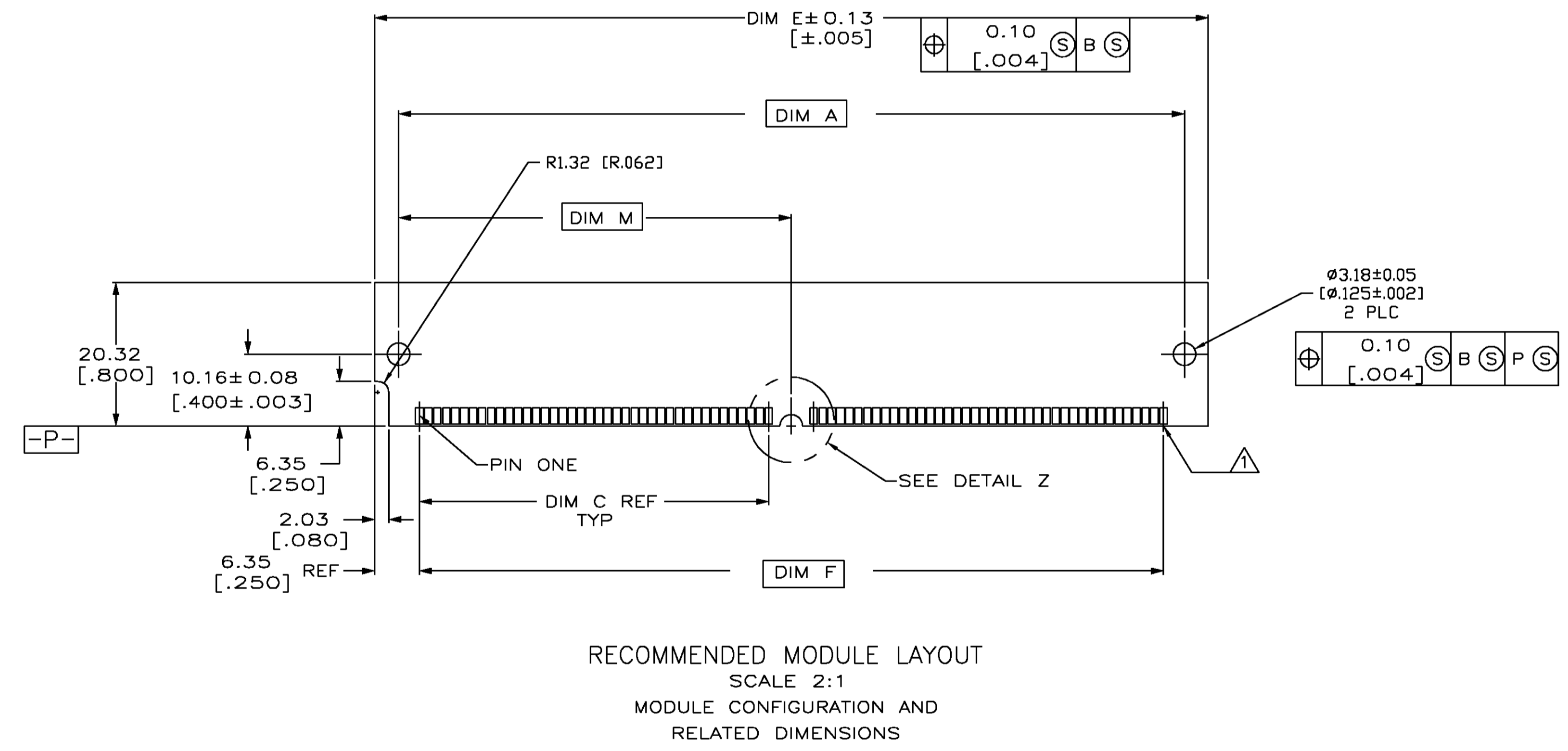

OBSOLETE	58.22[2.292]	127.00[5.000]	110.49[4.350]	123.19[4.850]	63.50[2.500]	52.07[2.050]	130.81[5.150]	116.43[4.584]	84	8-382481-4
OBSOLETE	55.68[2.192]	121.92[4.800]	105.41[4.150]	118.11[4.650]	60.96[2.400]	49.53[1.950]	125.73[4.950]	111.35[4.384]	80	8-382481-0
	50.60[1.992]	111.76[4.400]	95.25[3.750]	107.95[4.250]	55.88[2.200]	44.45[1.750]	115.57[4.550]	101.19[3.984]	72	7-382481-2
OBSOLETE	48.06[1.892]	106.68[4.200]	90.17[3.550]	102.87[4.050]	53.34[2.100]	41.91[1.650]	110.49[4.350]	96.11[3.784]	68	6-382481-8
OBSOLETE	30.28[1.192]	71.12[2.800]	54.61[2.150]	67.31[2.650]	35.56[1.400]	24.13[.950]	74.93[2.950]	60.55[2.384]	40	4-382481-0
	DIM M	DIM J	DIM F	DIM E	DIM D	DIM C	DIM B	DIM A	POSN	

THIS DRAWING IS A CONTROLLED DOCUMENT.		DATE	7-25-90
DRAWN BY		CHK	R. TALLEY
DIMENSIONS:		APPROVED	NAME
0 PLC	±	PRODUCT SPEC	
1 PLC	±	APPLICATION SPEC	
2 PLC	±	WEIGHT	
3 PLC	±	CUSTOMER DRAWING	
4 PLC	±	SCALE	4:1
5 PLC	±	SHEET	2 OF 2
6 PLC	±	REV	G
7 PLC	±		
8 PLC	±		
9 PLC	±		
10 PLC	±		

AMP Tyco Electronics Corporation
 mt. joy, pa 17552

SIMM II, RTANG,
 1.27 [.050] CENTERLINE ASSY
 3.18 [1.25] HGT

SIZE A1 CAGE CODE 00779 DRAWING NO. 382481
 WEIGHT - - - - -
 FINISH - - - - -