

USB dongle for SPIRIT1 low power RF modules SP1ML-868 and SP1ML-915

Data brief

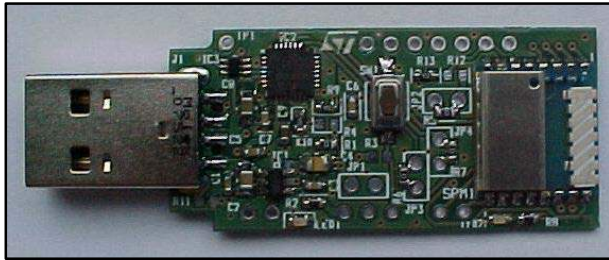

Features

- Based on SPIRIT1 sub GHz modules SP1ML-868 and SP1ML-915
- USB interface and power supply
- RESET button
- On-board antenna
- RoHS compliant

Description

The STEVAL-SP1ML868 and STEVAL-SP1ML915 boards are design tools that allow evaluation of ST's SP1ML-868 and SP1ML-915 low power RF modules in a quick and simple way.

The dongle includes the module to evaluate, an on-board RF antenna, and a USB connector. The USB connector is used to connect the dongle to a PC, to access the sub GHz RF module and to supply the dongle.

The STEVAL-SP1ML868 and STEVAL-SP1ML915 downloaded firmware enables the user to create a SPIRIT1 link using simple AT commands.

The SP1ML-based dongle is not qualified. It is a demonstration tool only, to be used strictly for evaluation purposes. It is not a product in itself.

1 Recommended operating conditions

Table 1: Recommended operating conditions

Symbol	Parameter	Conditions	Min.	Typ.	Max.	Unit
V _{DD}	Board supply voltage	-20 °C < T < 70 °C	4.5	5	5.5	V
T _{op}	Operating case temperature range		-20		+70	°C

2 Dongle layout

Figure 1: Dongle component layout, top side

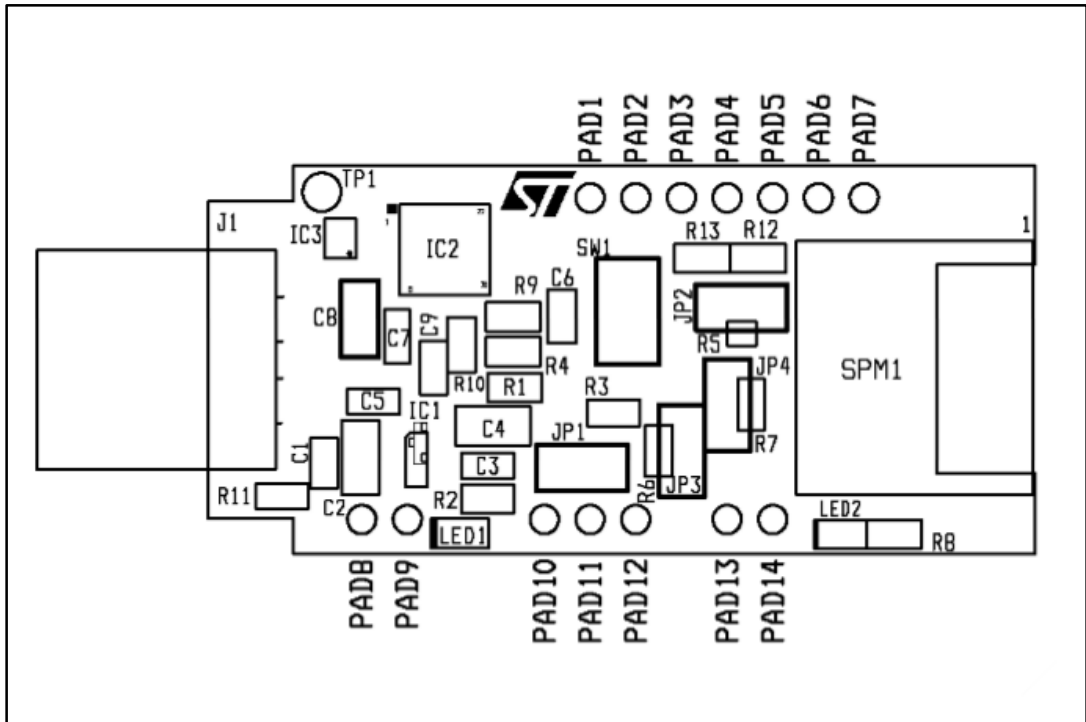
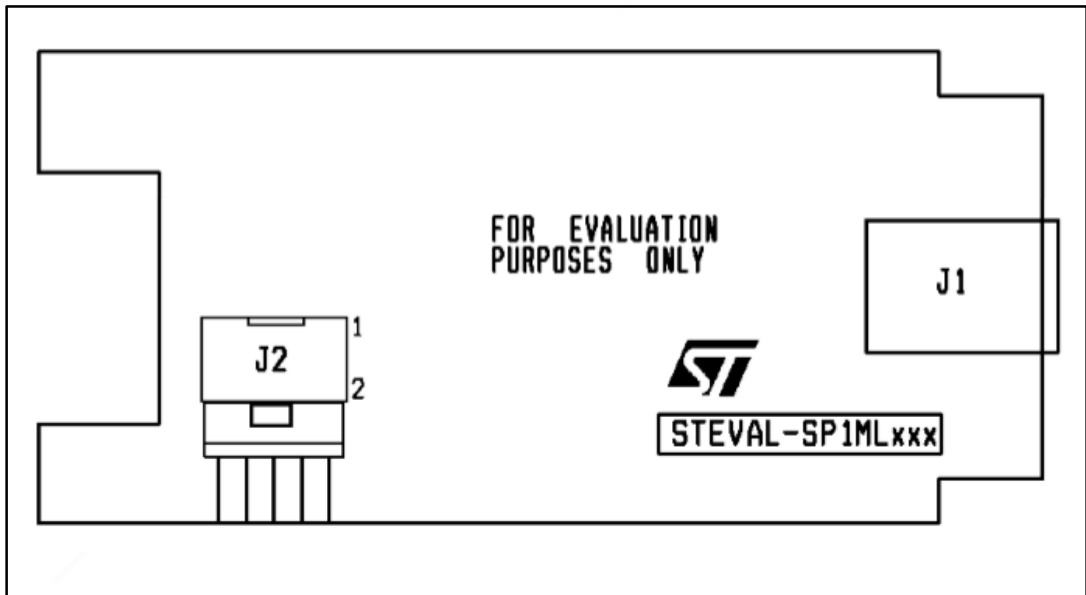

Figure 2: Dongle component layout, bottom side



3 I/O Connections

3.1 Pad references

In addition to the USB plug, several pads are also available. Pads 1 to 14 (indicated by the yellow boxes in the figure below) render the SP1ML-868 / SP1ML-915 module pins available to the user.

There are also six jumpers (indicated by red boxes) for current absorption purposes and for reprogramming the module firmware.

Figure 3: Available pads and jumpers

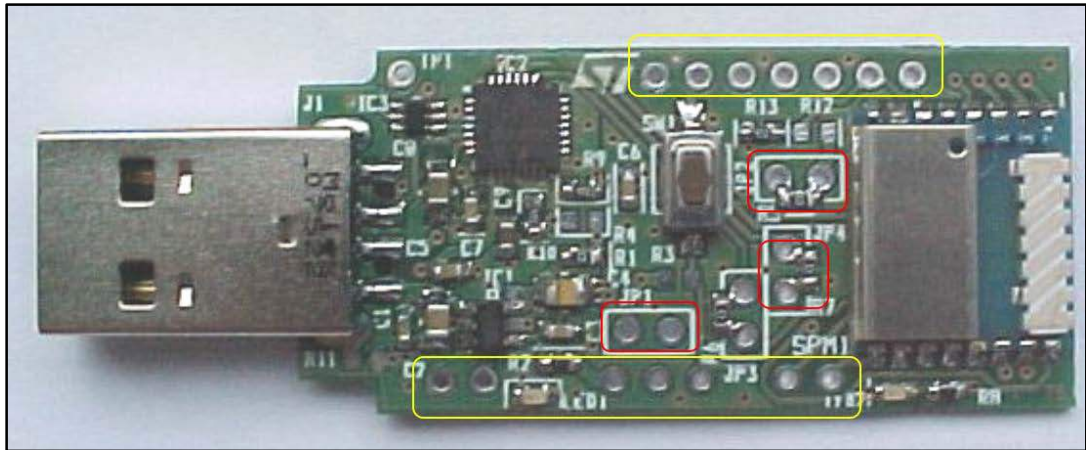

Table 2 provides a description of the pad connections.

Table 2: Pad connections

Description		
Pad	1	GND (SP1ML-868 / SP1ML-915MODULE GND)
	2	MODE0 SP1ML-868 / SP1ML-915 I/O signal
	3	WKUP SP1ML-868 / SP1ML-915 signal (WAKE-UP high level digital voltage / SHUTDOWN low level digital voltage)
	4	GPIO0 SP1ML-868 / SP1ML-915 programmable I/O signal
	5	GPIO1 SP1ML-868 / SP1ML-915 programmable I/O signal
	6	MODE1 SP1ML-868 / SP1ML-915 programmable I/O signal
	7	TxRx_LED SP1ML-868 / SP1ML-915 programmable I/O signal (LED2 is internally connected to this signal)
	8	GND
	9	+5 V (USB)
	10	+3.3 V
	11	BOOT0 (boot pin used for firmware downloading - used for testing purpose)
	12	Reset - connected in parallel to on-board reset switch
	13	SWCLK SP1ML-868 / SP1ML-915 I/O signal (firmware dependent)
	14	SWDIO SP1ML-868 / SP1ML-915 I/O signal (firmware dependent)

4 Reset switch

A reset switch (SW1) is present on the dongle. When SW1 is pressed the SP1ML-868 / SP1ML-915 module is forced to reset.

Figure 4: Reset switch

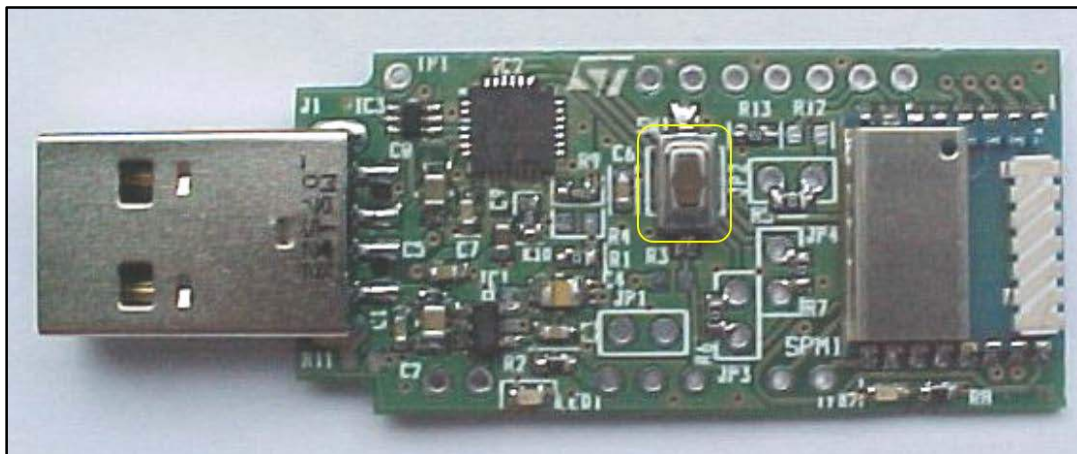

5 Dongle schematics

Figure 5: Dongle circuit schematic

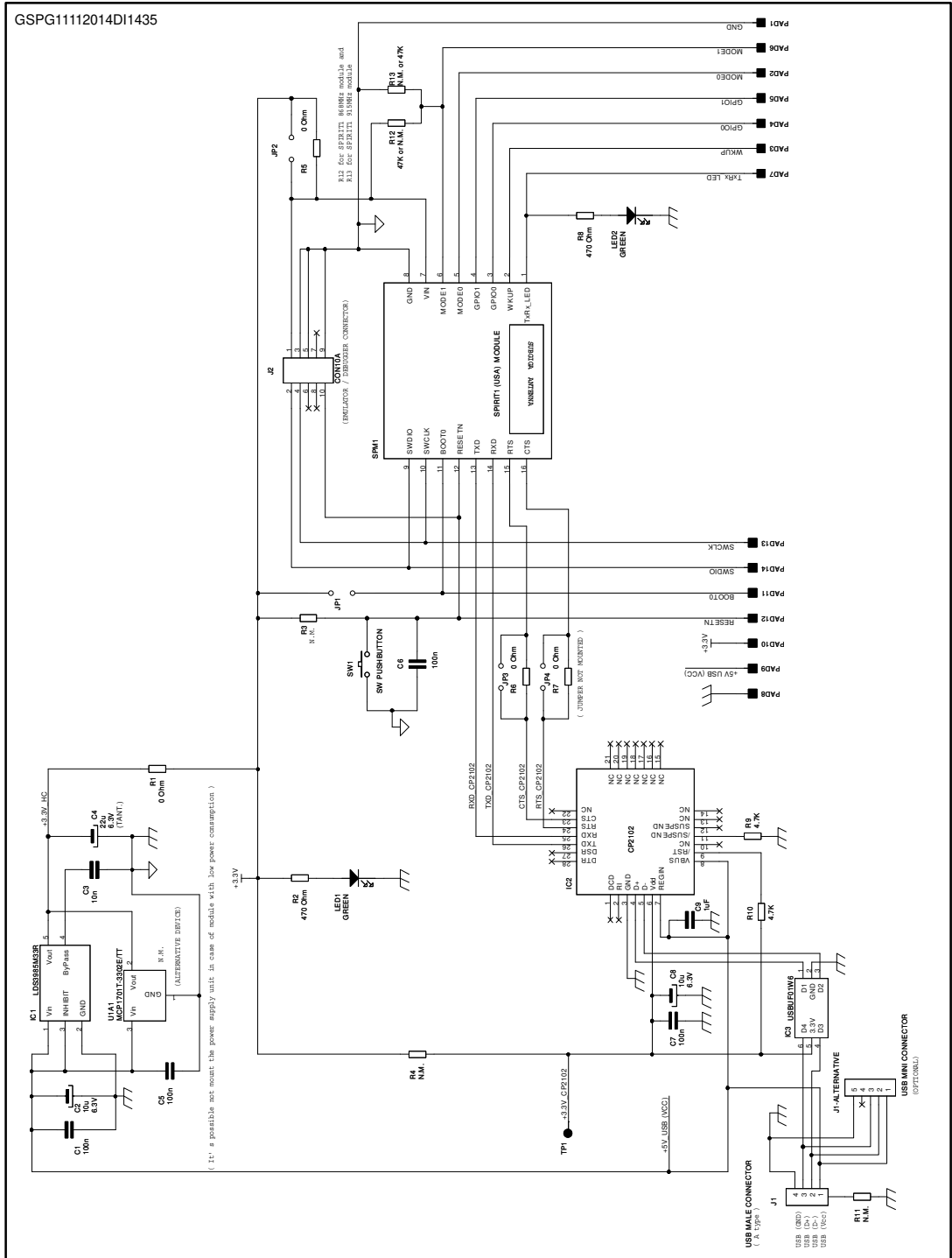

6 Revision history

Table 3: Document revision history

Date	Rev	Changes
22-Jan-2015	1	First release.

IMPORTANT NOTICE – PLEASE READ CAREFULLY

STMicroelectronics NV and its subsidiaries ("ST") reserve the right to make changes, corrections, enhancements, modifications, and improvements to ST products and/or to this document at any time without notice. Purchasers should obtain the latest relevant information on ST products before placing orders. ST products are sold pursuant to ST's terms and conditions of sale in place at the time of order acknowledgement.

Purchasers are solely responsible for the choice, selection, and use of ST products and ST assumes no liability for application assistance or the design of Purchasers' products.

No license, express or implied, to any intellectual property right is granted by ST herein.

Resale of ST products with provisions different from the information set forth herein shall void any warranty granted by ST for such product.

ST and the ST logo are trademarks of ST. All other product or service names are the property of their respective owners.

Information in this document supersedes and replaces information previously supplied in any prior versions of this document.

© 2015 STMicroelectronics – All rights reserved