

PART NUMBER	REV	FIRST USED
466089-2	F	565435-5

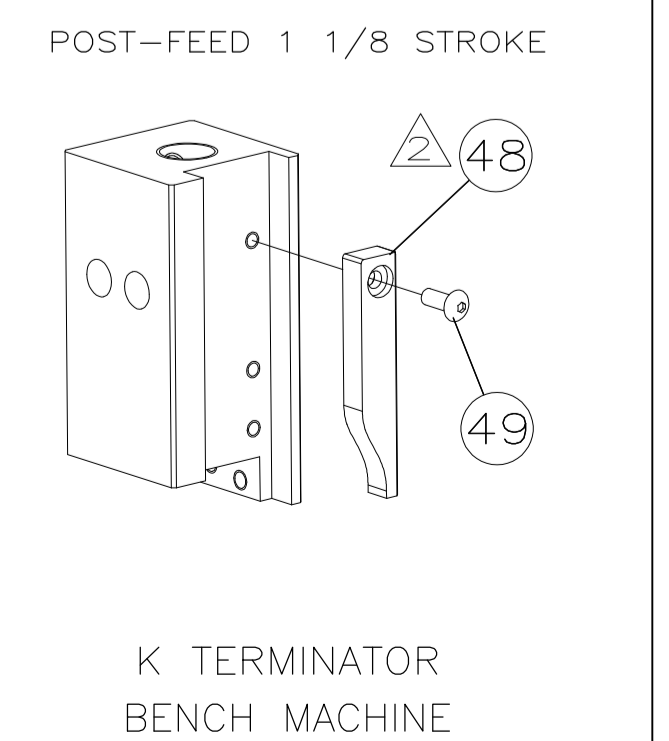
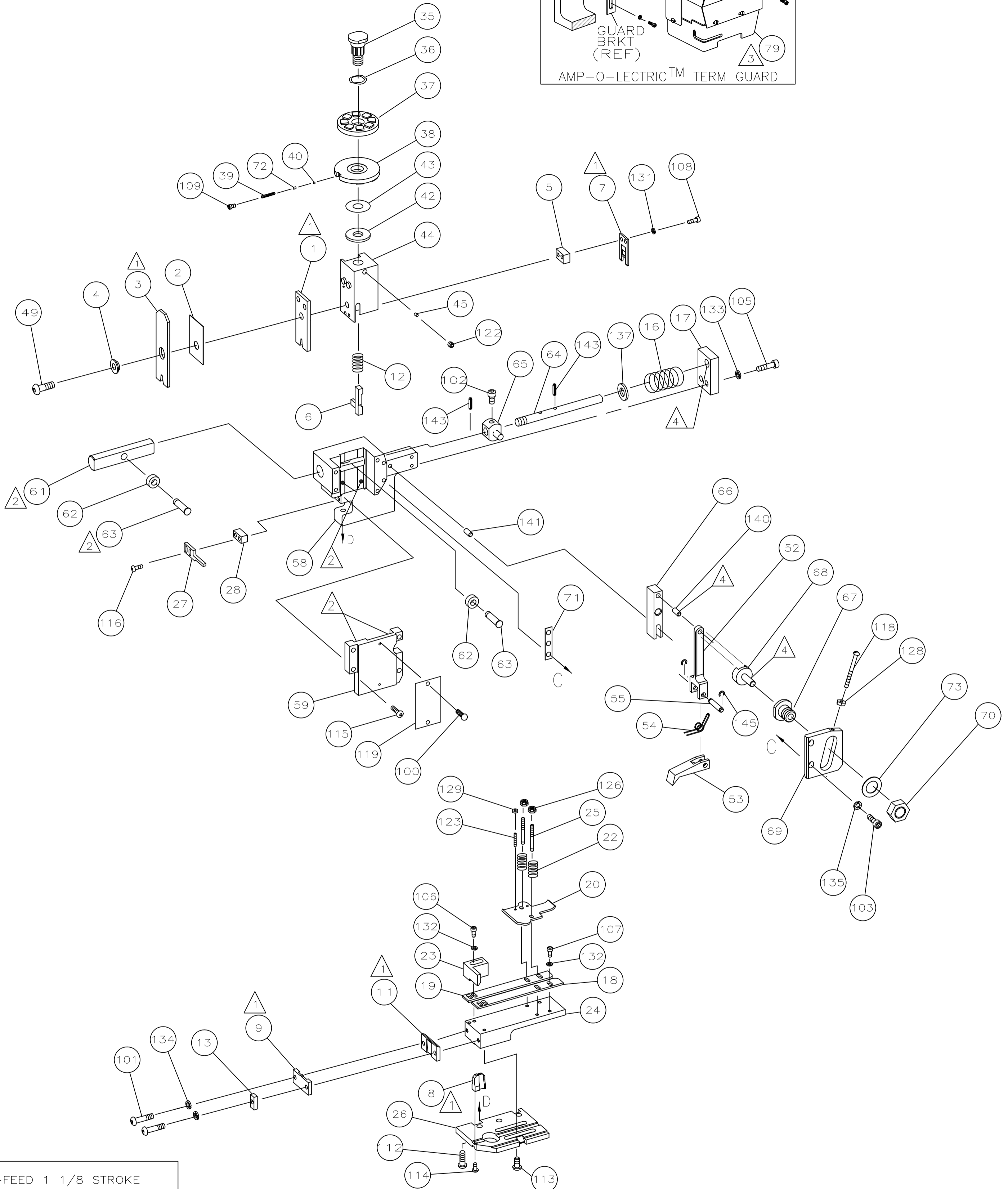
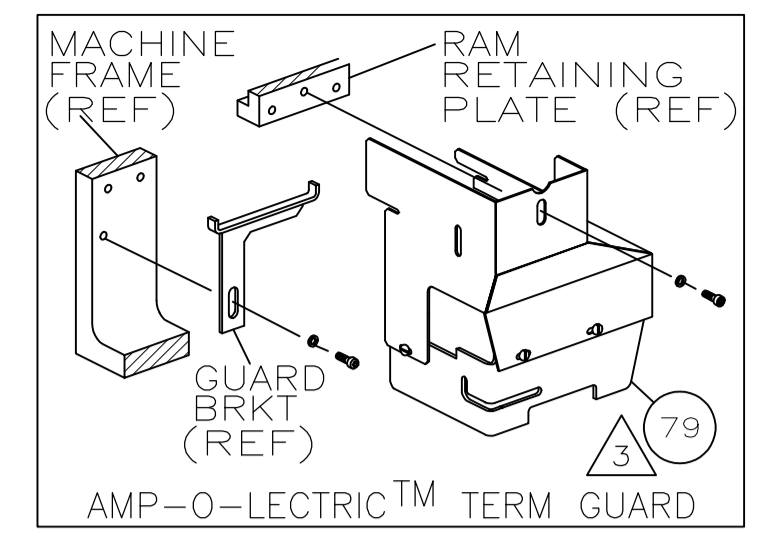

- 1 RECOMMENDED SPARE PARTS.
- 2 GREASE LIGHTLY.
- 3 GUARD MUST BE IN PLACE WHEN OPERATING APPLICATOR.
- 4 LUBRICATE DAILY USING NO. 20 MACHINE OIL.

TERMINAL NAME: -					
60469					
CRIMPING DATA					
PAD LTR	CRIMP HEIGHT	WIRE SIZE			
A	.041 ±.002	20			
B	.037 ±.002	22			
C	.034 ±.002	24			
D	NOT	USED			
CRIMP	SIZE	TYPE	RANGE		
WIRE	.055	F	24-20		
INSUL	.120	F	.090-.130		
WIRE STRIP LENGTH	TERM APPL SPEC	FEED	APPL INSTRUCTION	SET UP GAGE	LAYOUT
.150-.180	114-2080	.621	AI-8039	458638-1	-

REF -	21045-3	RING, RETAINING "C"(ø.187)FEED FINGER PIN	145
			144
REF -	5-21028-1	PIN,SLOT SPR(ø.125x.50)FD ADJ ROD	143
			142
REF -	1-21030-7	PIN,DOWEL(ø.187x1.50)HOUSING	141
REF -	1-21030-1	PIN,DOWEL(ø.187x.50)LEVER	140
			139
			138
REF -	21899-4	WASHER,FLAT(ø5/16)SCR ADJ	137
			136
REF -	21024-5	WASHER,LOCK(#10)FEED ADJ PLATE	135
2 -	21024-5	WASHER,LOCK(#10)SHEAR PLATE	134
REF -	21024-5	WASHER,LOCK(#10)FEED GUIDE ROD	133
5 -	21024-4	WASHER,LOCK(#8)STRIP GUIDE	132
2 -	21024-4	WASHER,LOCK(#8)SHEAR BLADE	131
			130
2 -	21018-4	NUT,HEX(4-40)DRAG	129
REF -	21068-5	NUT,HEX(6-32)FEED ADJ PLATE	128
			127
2 -	21022-2	NUT,HEX SELF-LKG(8-32)DRAG STUD	126
			125
			124
2 -	4-21078-8	SCR,SET OVAL PT(4-40x.75)DRAG	123
1 -	21009-2	SCR,SET(1/4-20x.25)(LOC-WEL)RAM	122
			121
1 -	2-21003-0	SCR,FHC(6-32x.50)CAM	120
1 -	461264-1	PLATE, IDENTIFICATION	119
REF -	3-21064-2	SCR,RH(6-32x1.50)FEED ADJ	118
			117
2 -	2-21002-2	SCR,BHSC(8-32x.50)STRIPPER	116
REF -	2-21002-9	SCR,BHSC(10-32x.75)HSG CAP	115
1 -	22733-8	SCR,BHSC(8-32x.38)(LOC-WEL)ANVIL	114
4 -	3-21002-3	SCR,BHSC(1/4-20x.50)STR GDE PL	113
REF -	1-24073-9	SCR,BHSC(1/4-20x.75)BASE PL	112
			111
			110
1 -	23030-1	SCR,SHC(6-32x.25)(LO-WEL)CP DISC	109
2 -	2-21000-6	SCR,BHC(8-32x.38)SHEAR BLADE	108
3 -	7-21000-4	SCR,SHC(8-32x.31)STRIP GUIDE	107
2 -	2-21000-8	SCR,SHC(8-32x.62)STRIP GUIDE	106
REF -	3-21000-7	SCR,SHC(10-32x.75)FEED ROD GUIDE	105
			104
REF -	3-21000-6	SCR,SHC(10-32x.62)FEED ADJ BLOCK	103
REF -	3-21000-4	SCR,SHC(10-32x.38)PIVOT BLOCK	102
2 -	3-21000-8	SCR,SHC(10-32x.88)SHEAR PLATE	101
2 -	21017-2	SCR,DRIVE(#2x.19)ID PLATE	100
			99
			98
			97
			96
			95
			94
			93
			92
			91
			90
			89
			88
			87
			86
			85
			84
			83
			82
			81
			80
3 REF -	455745-1	GUARD, WINDOW	79
			78
			77
			76

QTY REQD PER ASSY	U/M	PART NO	DESCRIPTION
-2	U/M		

LOC	DIST	REVISIONS			
F	LTR	DESCRIPTION	DATE	BY	APPV
A	66	ECR-07-00	4-2007	MY	GB

					75
					74
REF -	458109-1	WASHER, SPECIAL			73
2 -	690603-1	SPRING, ASSIST			72
REF -	690517-1	SPACER			71
REF -	22594-8	NUT, HEX			70
REF -	240628-1	PLATE, ADJUSTMENT			69
REF -	240626-1	SHAFT, PIVOT			68
REF -	240633-1	BUSHING			67
REF -	455680-1	LEVER, INTERMEDIATE			66
REF -	240629-1	BLOCK, PIVOT			65
REF -	240632-2	SCR, ADJ FEED ROD			64
REF -	240659-3	PIN, CAM ROLLER			63
REF -	240658-1	ROLLER, CAM			62
REF -	454398-1	ROD, FEED			61
					60
REF -	454220-1	CAP, RAM			59
REF -	453736-1	HOUSING			58
					57
					56
REF -	240624-1	PIN, FEED FINGER			55
REF -	691499-1	SPRING, FEED FINGER			54
REF -	240635-1	FINGER, FEED			53
REF -	240634-3	LEVER, TERMINAL FEED ARM			52
					51
					50
1 -	7-21002-9	BOLT, CRIMPER			49
1 -	690501-3	CAM POST-FEED, 1 1/8 STROKE			48
					47
					46
1 -	690191-1	PLUG, NYLON			45
1 -	455674-1	RAM			44
1 -	690125-1	WASHER, LAMINATED			43
1 -	690124-1	WASHER, RAM			42
					41
2 -	23241-6	BALL, STEEL			40
2 -	690170-1	SPRING, COMPRESSION			39
1 -	690142-1	DISC, INSULATION			38
1 -	5-690692-9	DISC, WIRE			37
1 -	22480-5	WASHER, SPRING			36
1 -	690212-1	POST, RAM			35
					34
					33
1 -	458980-1	APPLICATOR, BASIC (SUB ASSY)			32
					31
					30
					29
1 -	3-690451-2	SPACER, STRIPPER			28
1 -	240639-1	STRIPPER			27
REF -	455675-1	PLATE, BASE			26
2 -	22354-8	DRAG, STUD			25
1 -	455678-1	PLATE, STRIP GUIDE			24
1 -	240825-2	PLATE, STRIP HOLD			23
2 -	4-22281-1	SPRING, DRAG			22
					21
1 -	454177-1	DRAG, STOCK			20
1 -	454204-1	GUIDE, STRIP (REAR)			19
1 -	454204-1	GUIDE, STRIP (FRONT)			18
REF -	454178-1	GUIDE, FEED ROD			17
REF -	4-22284-9	SPRING, FEED RETURN			16
					15
					14
1 -	690481-8	SPACER, HOLD DOWN			13
1 -	23846-1	SPRING, HOLD DOWN			12
1 -	240644-1	PLATE, REAR SHEAR			11
					10
1 -	690482-6	PLATE, FRONT SHEAR			9
1 -	2-240655-8	ANVIL			8
1 -	690474-6	BLADE, SLUG			7
1 -	2-455892-2	HOLD DOWN TERMINAL			6
1 -	3-240641-8	SPACER, SHEAR BLADE			5
1 -	238009-1	SPACER, TUBULAR			4
1 -	2-456134-6	CRIMPER, INSULATION			3
1 -	455888-4	SPACER, INSULATION			2
1 -	1-456402-6	CRIMPER, WIRE			1

QTY REQD PER ASSY	U/M	PART NO	DESCRIPTION
-2	U/M		

THIS DRAWING IS A CONTROLLED DOCUMENT.

APPROVED BY: M. YOUNGER, G. RAILLEY, G. RAILLEY

DATE: 19APR2007

TYCO ELECTRONICS CORPORATION, Harrisburg, PA 17105-3608

END FEED HDM APPLICATOR

DIMENSIONS: INCHES. TOLERANCES UNLESS OTHERWISE SPECIFIED: 0 PLC ±.000, 1 PLC ±.001, 2 PLC ±.002, 3 PLC ±.003, 4 PLC ±.005, ANGLES ±.001

MATERIAL: FINISH

WEIGHT: A1 00779 466089-2

CUSTOMER DRAWING. SCALE: SHEET 1 OF 1 REV F