

| LOC | | DIST | | REVISIONS | | | |
|-----|-----|-----------------------|--------|-----------|------|--|--|
| P | LTR | DESCRIPTION | DATE | DNW | APVD | | |
| G | | REV PER ECO 15-001580 | 3-9-15 | CT | CD | | |

RAISED NUMBERS FOR IDENTIFICATION OF CIRCUIT HOLES.

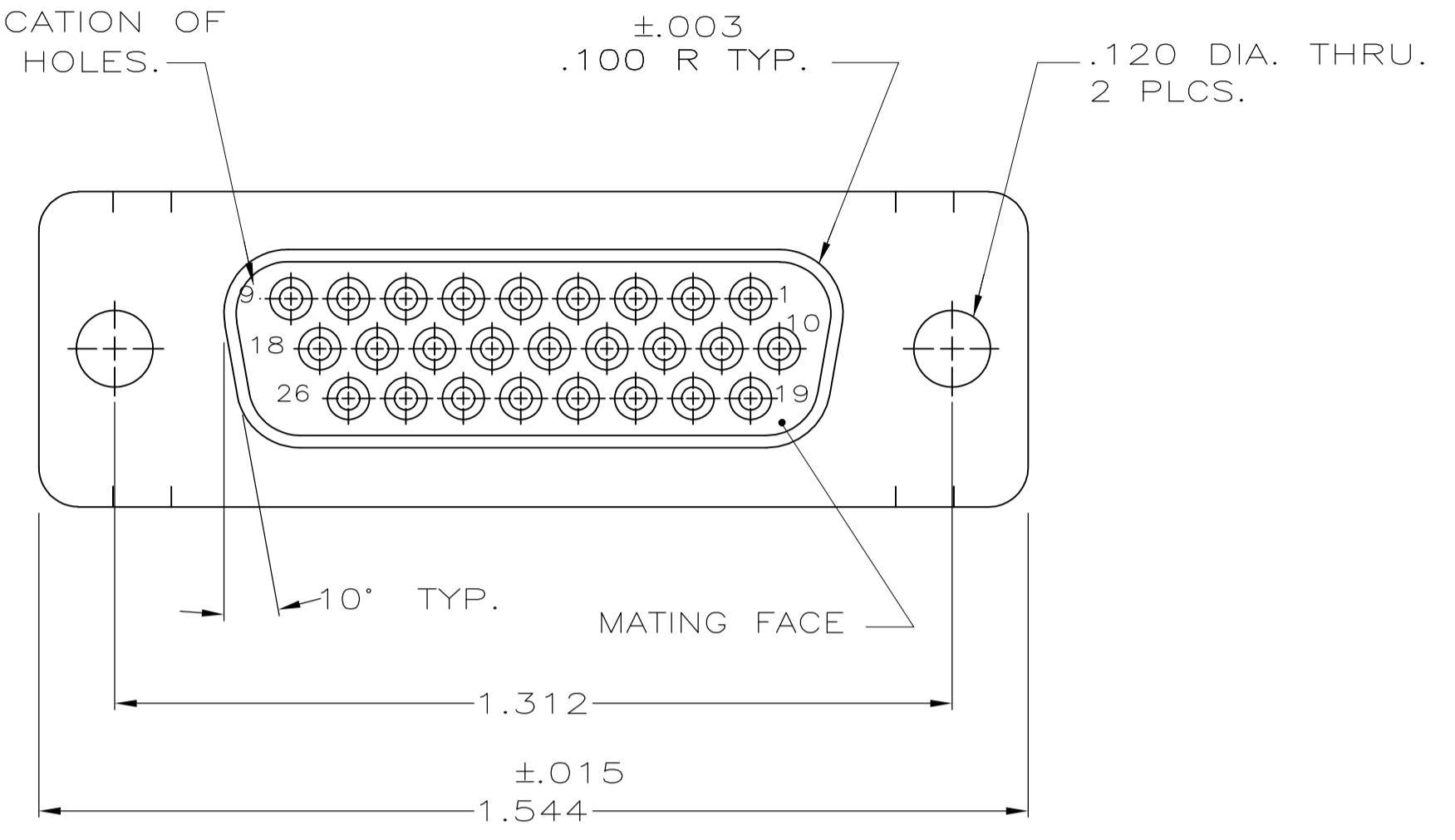

1. THIS RECEPTACLE WILL MATE WITH ANY SIZE 2,26 POSN. PLUG IN AMPLIMITE SERIES.
 2. CONNECTOR SUPPLIED WITHOUT CONTACTS; SHOWN FOR ILLUSTRATION ONLY.
 3. BE-CU RETENTION CLIPS ARE INCLUDED IN INSERTS AND INSTALLED WITH TINES POINTING TOWARDS MATING FACE.
 4. OVERALL DIMENSIONS DO NOT INCLUDE RAISED CAVITY IDENTIFICATION.
 5. MARKING FAR SIDE REFERS TO WIDE SIDE OF KEYSTONE. NEAR SIDE REFERS TO NARROW SIDE OF KEYSTONE.
- ⚠ 100% INSPECTION REQUIRED PER BOEING 1B01:
 A. VISUAL
 B. DWV
 C. IR
7. CUSTOMER REQUIRES SINGLE LOT DATE CODE.

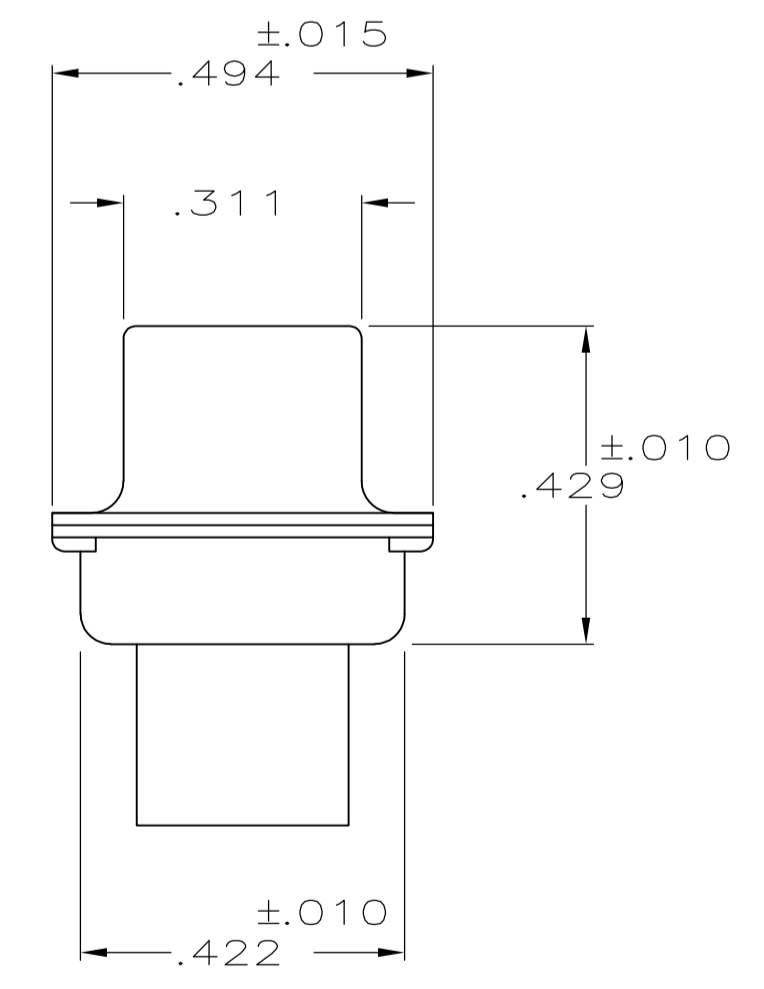
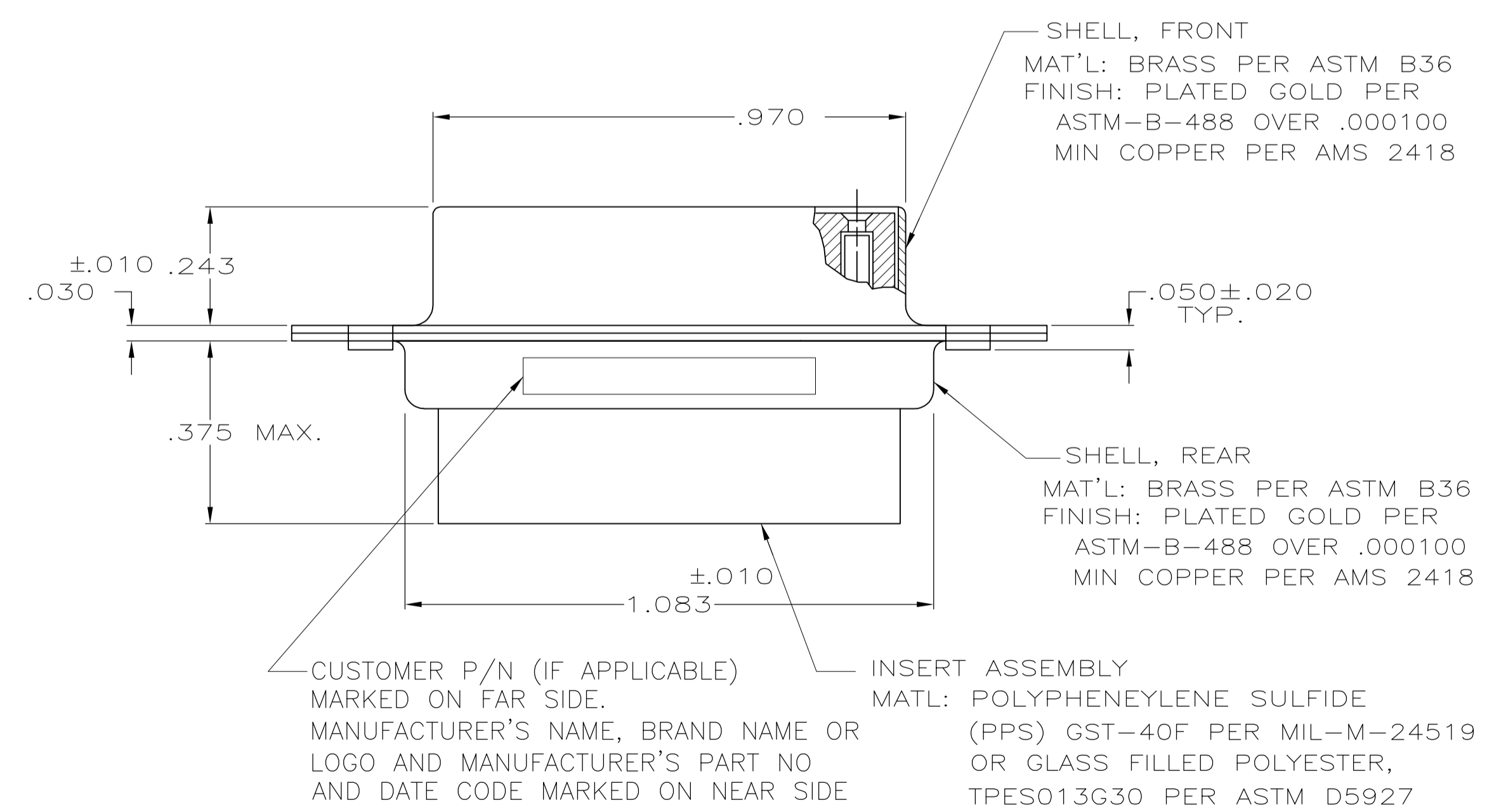

| | | |
|---------|----------------------|------------|
| REMARKS | 1B01-002RHW | 1-211644-1 |
| | 1B01-002 | 211644-1 |
| REMARKS | CUSTOMER PART NUMBER | PART NO. |

THIS DRAWING IS A CONTROLLED DOCUMENT.

| | | | | | |
|----------------------|--|----------------------|------------------------|-----------------|--|
| DIMENSIONS: INCHES | TOLERANCES UNLESS OTHERWISE SPECIFIED: | DIN D. ERDMAN 3-8-84 | APVD G. SACUNAS 7-5-84 | NAME | RECEPTACLE ASS'Y, AMPLIMITE, 26 POSN., SIZE 2, SERIES 90, NON-MAGNETIC |
| 0 PLC ± - | 1 PLC ± - | 2 PLC ± - | 3 PLC ± .005 | 4 PLC ± - | ANGLES ± - |
| MATERIAL SEE CALLOUT | FINISH SEE CALLOUT | WEIGHT - | SIZE A1 | CAGE CODE 00779 | DRAWING NO. 211644 |
| CUSTOMER DRAWING | | | SCALE 4:1 | SHEET 1 OF 1 | REV G |

STE TE Connectivity